

GORTITE® CUSTOM PROTECTIVE COVERS

Gortite® Stock Rod Boots

Provide maximum protection against cylinder rod scoring from chips, abrasive particles and other impinging objects.

Manufactured of rugged neoprene coated nylon fabric, Gortite Rod Boots give millions of trouble free operations in temperature ranges of -40° F to 220° F.

Rod boots are available in 12 stock sizes without tooling charges or minimum order quantities. All shipments are made within three working days.

BENEFITS:

- Reduce frequency of shaft seal replacements
- Prevent rod scoring
- Eliminate nicking of shafts and ball screws
- Protect against impinging chips
- Guard against grit abrasion
- Shield from corrosive splatter



Mounting accessories - C205 flange-type back up plates or C208 collar clamps - can be added to your order upon request

AVAILABLE SIZES:

ROD BOOT STYLE	SRA-15	SRB-15	SRC-15	SRD-15	SRE-15	SRF-15	SRG-25	SRH-25	SRJ-25	SRK-25	SRM-25	SRO-25
Inside Diameter	3/4"	1-1/8"	1-1/2"	1-7/8"	2-3/8"	2-7/8"	3-3/8"	3-7/8"	4-1/2"	5"	5-3/8"	7-1/4"
Outside Diameter	3"	3-3/8"	3-3/4"	4-1/8"	4-5/8"	5-1/8"	7"	7-1/2"	8-1/4"	8-3/8"	9-1/2"	11"
Retracted Length (every 12" extended)	3/4"	3/4"	3/4"	3/4"	3/4"	3/4"	1/2"	1/2"	1/2"	1/2"	1/2"	1/2"
Collars - Available I.D. Sizes (must be ordered in 1/8" increments)	1/2" to 3"	1/2" to 3-3/8"	1/2" to 3-3/4"	1/2" to 4-1/8"	1/2" to 4-5/8"	1/2" to 5-1/8"	1/2" to 7"	1/2" to 7-1/2"	1/2" to 8-1/4"	1/2" to 8-3/8"	1/2" to 9-1/2"	1/2" to 11"

Quick Turn Bellows

Take advantage of A&A's expedited ordering service. Qualified bellows ship within one business day if ordered before 2:00pm CST, after all documentation is in place. To order, go to: www.gortite.com/quick-turn

QUOTE REQUEST

GORTITE® STOCK ROD BOOTS



Date _____
 Quantity _____
 Company Name _____
 Contact _____

Address _____
 City _____ State/Province _____
 Country _____ Zip/Postal Code _____
 Telephone _____ Fax _____
 Email _____

1. ROD BOOT STYLE

- SRA-15 SRB-15 SRC-15 SRD-15 SRE-15 SRF-15
 SRG-25 SRH-25 SRJ-25 SRK-25 SRM-25 SRO-25

ROD BOOT STYLE	SRA-15	SRB-15	SRC-15	SRD-15	SRE-15	SRF-15	SRG-25	SRH-25	SRJ-25	SRK-25	SRM-25	SRO-25
Inside Diameter	3/4"	1-1/8"	1-1/2"	1-7/8"	2-3/8"	2-7/8"	3-3/8"	3-7/8"	4-1/2"	5"	5-3/8"	7-1/4"
Outside Diameter	3"	3-3/8"	3-3/4"	4-1/8"	4-5/8"	5-1/8"	7"	7-1/2"	8-1/4"	8-3/8"	9-1/2"	11"
Retracted Length (every 12" extended)	3/4"	3/4"	3/4"	3/4"	3/4"	3/4"	1/2"	1/2"	1/2"	1/2"	1/2"	1/2"
Collars - Available I.D. Sizes (must be ordered in 1/8" increments)	1/2" to 3"	1/2" to 3-3/8"	1/2" to 3-3/4"	1/2" to 4-1/8"	1/2" to 4-5/8"	1/2" to 5-1/8"	1/2" to 7"	1/2" to 7-1/2"	1/2" to 8-1/4"	1/2" to 8-3/8"	1/2" to 9-1/2"	1/2" to 11"

2. ROD BOOT DIMENSIONS

Please specify in inches

Outer diameter of part to be covered: _____
 Extended Length: _____ (without ends, in 12" increments)
 Travel distance: _____

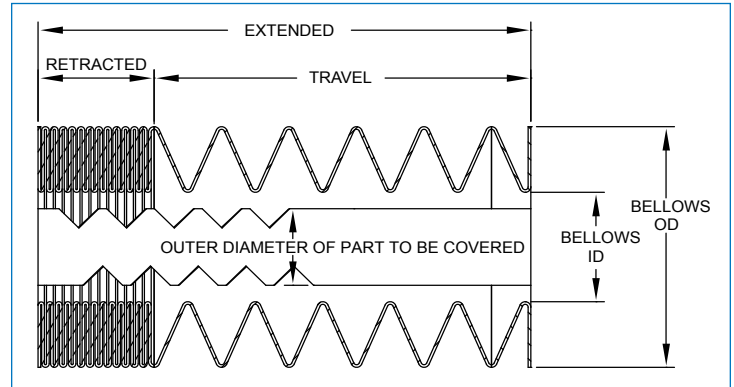

3. END DIMENSIONS

Choose end type - standard flange or collar

One End:

Standard Flange
 outer diameter: _____ inner diameter: _____

Collar
 outer diameter: _____ width: _____

Other End:

Standard Flange
 outer diameter: _____ inner diameter: _____

Collar
 outer diameter: _____ width: _____

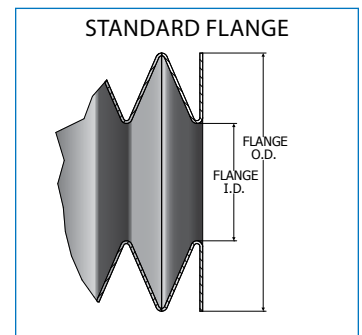
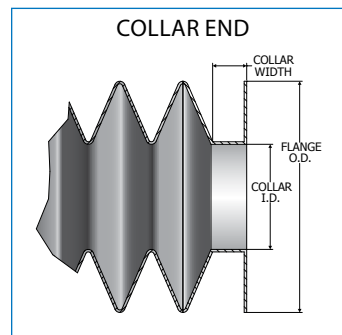

4. MOUNTING ACCESSORIES

Please check options desired

- C208 Clamp (0.5" minimum inner diameter)
 (C208 clamps are stocked in any size required, clamp band is 0.5" wide)
 C205 Flange-type back-up plate
 (If flange-type back-up plates are required, please send sketch)
 C205 Flange-type back-up plate with mounting holes
 (Please send sketch indicating bolt hole pattern)

⇒ **PLEASE SEND THE COMPLETED FORM TO:**
 Fax: 262-786-3280 or Email: sales@aaman.com
 Gortite Division | www.gortite.com
 A&A Manufacturing Co., Inc.
 Phone: (262) 786-1500 or (800) 298-2066