

MISTING SHOWERS

MISTING AIR SHOWERS



APPLICATIONS:

Atmos-Tech Industries Misting Showers are used for the control and containment of hazardous dusts, powders and potent compounds. The Misting Shower provides a fine atomized fog to affix any loose powders to the users garment to prevent the powders from becoming airborne or migrating outside of the containment area during degowning. The addition of the Air Shower option aids in the removal of the contaminated water to the bottom containment pan.



AVAILABLE OPTIONS

- ALL STAINLESS STEEL CONSTRUCTION
- EPOXY PAINTED STEEL CONSTRUCTION
- POLY-PRO
- HEPA/ULPA FILTRATION
- CUSTOM SIZES
- CUSTOM CONFIGURATIONS
- DRENCH SHOWERS
- STEP-OFF PLATFORMS
- SOILED GOWN CONTAINMENT
- MICROPROCESSOR CONTROLLED
- EXHAUST SYSTEMS

SPECIFICATIONS



MICROPROCESSOR CONTROLLED:

Allowing for custom adjustment of mist cycle duration, door interlock system, and air shower sequence. The control system can also be integrated to operate with house monitoring systems

FILTRATION:

Optional laminar flow HEPA/ULPA filtration systems can create and maintain up to a class 10 (ISO 4) environment inside the Shower

AIR SHOWER CYCLE:

The Air Shower cycle can be used to remove contaminants before entry into the clean area without the mist cycle, and as an aid to rid excess water after the mist cycle. The air shower cycle uses a high velocity air stream of 6000-8000 fpm to provide efficient scrubbing action of the cleanroom garment



ATMOS-TECH IND.
1108 POLLACK AVENUE, OCEAN, N.J. 07712
PHONE: (732) 493-8400

In line with our policy of continual product improvement, ATMOS-TECH, reserves the right to incorporate and use equipment and material to conform with the latest design of its products, and in keeping with the specifications of this equipment.



- 1 DIRECT DRIVE MOTOR BLOWER
- 2 99.99% V-BANK HEPA FILTER
- 3 DISPOSABLE PRE-FILTERS
- 4 NEMA 4 ELECTRICAL CONTROLS ENCLOSURE
- 5 PLC INTERFACE PANEL
- 6 EMERGENCY STOP BUTTON
- 7 ELECTRICAL JUNCTION BOX
- 8 INFRARED PRESENCE SENSOR
- 9 SS FRAMED DOORS
- 10 HIGH VELOCITY AIR NOZZLES
- 11 RETURN AIR DUCTS
- 12 SUPPLY AIR DUCTS
- 13 FLUORESCENT LIGHT FIXTURES
- 14 SERVICE PANELS
- 15 MISTING NOZZLES MOUNTED IN SERVICE PANELS
- 16 SPRINKLER HEAD PIPE AND SLEEVE

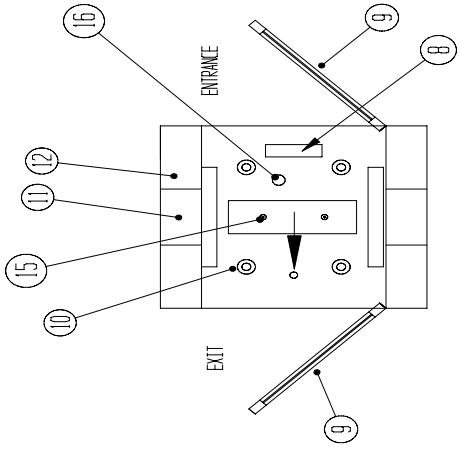
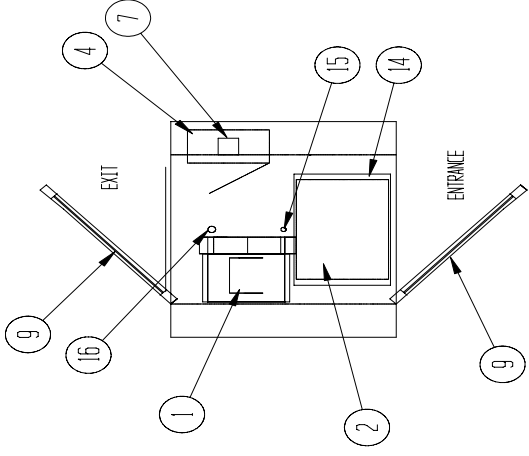

SECTION A-A

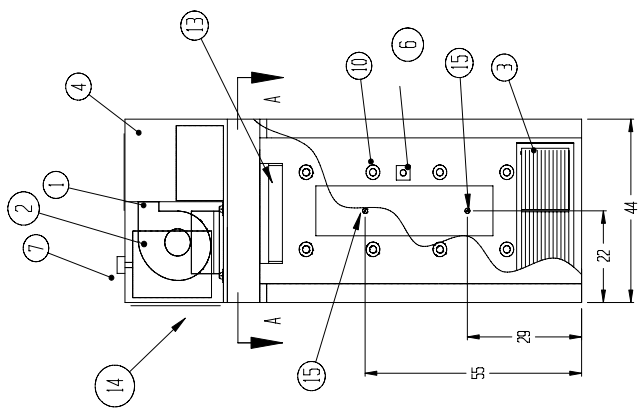

LEFT SIDE ELEVATION

PLAN VIEW

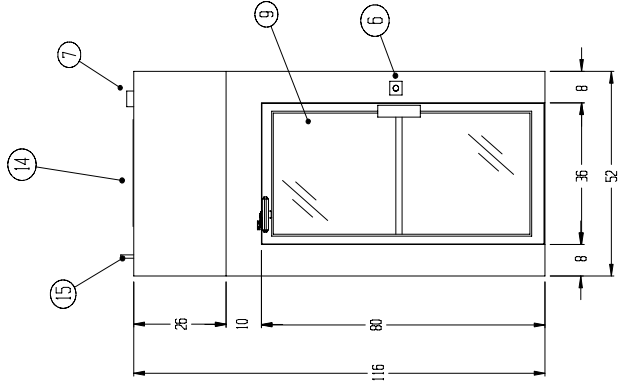

ENTRANCE SIDE ELEVATION

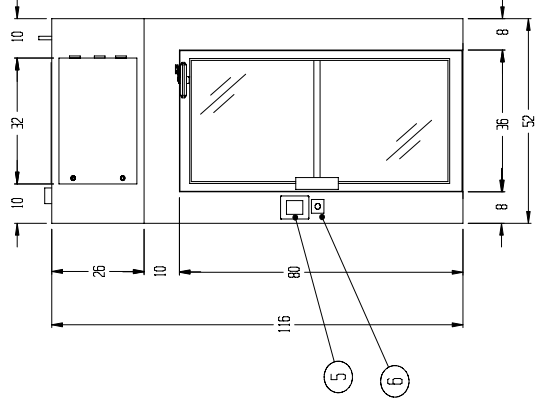

EXIT SIDE ELEVATION