



Sponsorship pg.35



Lock and Load pg.23



PowerArmor pg.22

 **TORKLIFT**
PINTERNATIONAL
OVER 35 YEARS OF INNOVATION, QUALITY, SAFETY.
PRODUCT CATALOG
TORKLIFT.COM • 2014



SuperTruss Extension pg.12



StableLoad pg.14



OVER 35 YEARS OF INNOVATION QUALITY SAFETY

CONTENTS

- [03] The Torklift Story
- [04] Customer Reviews
- [05] The Torklift Commitment
- [07] Towing
 - Light Duty - NEW
 - Accessories
 - Heavy Duty
 - Magnum Duty
 - Weight Distribution
 - Ballmount Accessories
 - Extension
 - Wiring Harness
- [15] Suspension
- [16] Auxiliary Power
 - HiddenPower - NEW
 - ExtendedPower - NEW
- [18] GlowStep Series
 - GlowStep
 - GlowGuide
 - SafeStep - NEW
 - DirtDestroyer - NEW
 - Accessories
- [23] Security
 - PowerArmor - NEW
 - Lock and Load - NEW
 - Fortress GasLock - NEW
- [26] Tie Downs
- [27] Turnbuckles
- [29] Storage & Stability
 - Wobble Stopper
 - Camper Packer
- [31] Displays
- [35] Certified Dealer
- [36] Sponsorship
- [37] Contact Information

Torklift International OUR STORY

It began with **ONE MAN.**

1958

The Torklift story starts in 1958 when Jon Kay began working at a hitch and tow shop in Tacoma, Washington. Through his experience, he decided he wanted to open his own shop someday.

1976

After several years of planning and accumulating equipment, he opens his own shop in Kent, Washington: Torklift Central Welding. Upon opening the doors for business, he begins fabricating his own line of products.

1981

Torklift Central Welding grows in success, doubling in size with the addition of two bays.

1988 - 1992

The expansion continues with the purchase of additional buildings and the demolition of the original building to make way for a larger shop.

1990

True Frame-Mounted Tie Downs are invented. They are the first product manufactured by Torklift and the first of their kind in the world.

1995

Torklift Central Welding purchases their first CNC plasma cutter.

1999

Torklift International is born. While Torklift Central Welding is still around today, they continue to conduct business as a separate company. Torklift International manufactures parts that are sold all over the world. But it all began with Jon Kay's dream to open a small hitch and tow shop.

1999

Torklift International ships their first SuperHitch and SuperTruss.

2003

The FastGun Turnbuckle is invented. It is the first turnbuckle of its kind with a quick-disconnect handle.

2004

Torklift International purchases their first dual-head, high def. CNC plasma.

2008

The SuperHitch line expands to include the SuperHitch Magnum.

2011

Torklift International moves to a new facility in Sumner, Washington to meet expansion needs.

Today

Torklift International continues to develop products and programs to further the RV and automotive industries. They maintain their commitment to customer service by being available 24 hours a day and living up to their Legendary Lifetime Warranty promise.

Jon Kay still continues to develop innovative products at Torklift International to this day.



Jon Kay



Contact Us
800.246.8132 Toll Free
www.torklift.com Web

Legendary Lifetime Warranty
We stand behind our products.
Everytime.

Torklift International REVIEWS

OUR PRODUCTS ARE THE BEST. PERIOD. Check out what our customers think.

Our Company

"The folks at Torklift are great! Their dealer support and quality parts are just a few reasons we use Torklift products exclusively."

Frank Henderson, Apache Camping Center

Our Customer Service

"Companies who act like their customers are important to them are all too rare these days. Torklift is one of those and should be supported whenever possible. Thanks again!"

Tom Crawford, Alberta, Canada

Towing

"Love to tow behind my camper and the SuperTruss! I feel no worries when I do, and that peace of mind is priceless."

Kyle Roberts, Centerville, UT

Tie Downs/Turnbuckles

"It is my opinion that any dealership not displaying the high quality Torklift line is not presenting to their customers the highest quality and strongest camper tie down system available."

Charles Loius, All Seasons RV

Suspension

"After years of frustration with bad sway, I finally installed StableLoads. Problem instantly solved. The sway is gone. It's a joy to drive. The StableLoads absolutely solved the problem."

Al Maher, Phoenix, Arizona

"Companies who act like their customers are important to them are all too rare these days. Torklift is one of those and should be supported whenever possible."

GlowGuide Handrail

"What I like is how sturdy the GlowGuide handrail is when you attach it to the step. It is so strong I can shake the whole RV with it."

Doug Carr, National Sales Manager, Arctic Fox

Storage/Security

"I feel a lot safer about my expensive camping equipment since using PowerArmor and Fortress GasLock. They give me peace of mind."

Lauren Jensen

The Torklift COMMITMENT

WE ARE COMMITTED to providing the best products.

When you see this badge, you know you can trust Torklift International's Legendary Lifetime Warranty.

We Stand Behind Our Products.

In fact, our products are so good, we'll even extend our warranty beyond our products.

When you use our **spring-loaded turnbuckles with our TRUE Frame-Mounted Tie Downs**, we'll also warranty the truck camper anchor points and truck frame.*



When you use our **StableLoad suspension upgrade** we'll also extend our Legendary Lifetime Warranty to your leaf springs.

*Call for details

Towing LIGHT DUTY



SuperHitch Hero 15K

Features and Benefits

- 1,500 lbs tongue weight/ 15,000 lbs tow when used with weight distribution
- First Torklift International SuperHitch built for half-ton trucks
- Strongest hitch built for half-ton trucks
- Double, vertical stacked receiver for strength, dual extension use and for accessory use in top receiver while towing
- No-drill applications
- Highest ratings in the industry
- Reinforced hitch pin locations to prevent common elongation wear known as "egging"
- Three piece assembly for easier installation
- Hitch pins included
- Legendary Lifetime Warranty
- Proudly made in the USA

For ordering, detailed product descriptions and footnotes see torklift.com. Applications added daily.



Contact Us
800.246.8132 Toll Free
www.torklift.com Web

Legendary Lifetime Warranty
We stand behind our products.
Everytime.

Towing ACCESSORIES

Torklift Genesis ^{New}

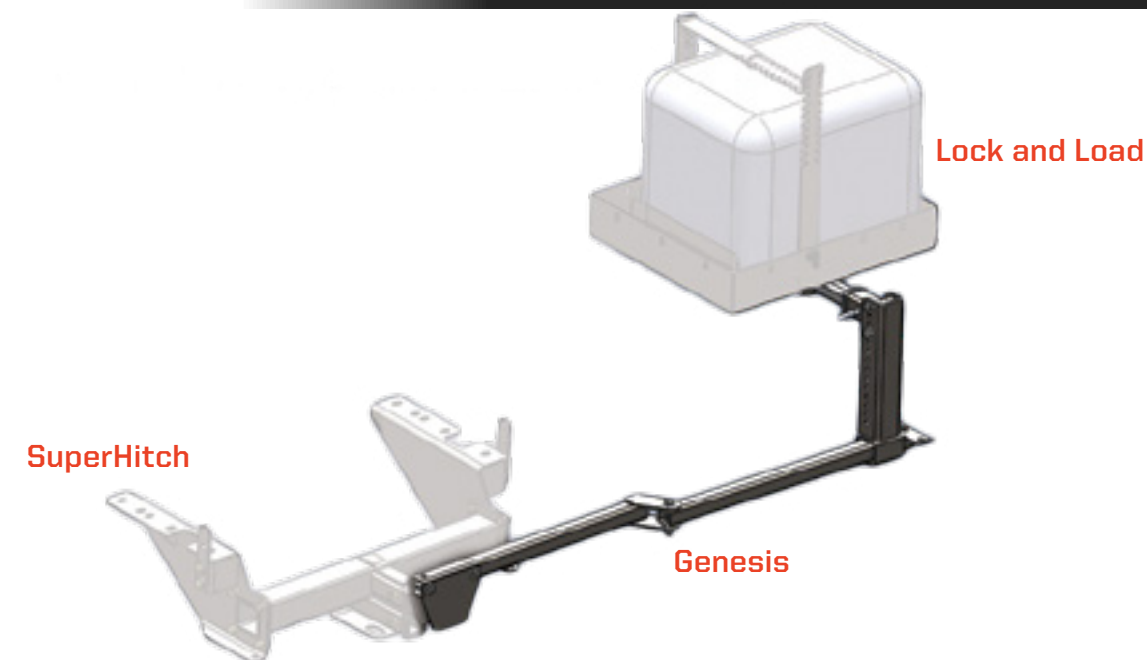

*Prototype image.

Features and Benefits

- Various attachments coming for carrying generators, bike racks, plasmas, welders, etc.
- Fits in top receiver so you can tow in bottom receiver
- Elbow arm allows for full range of motion
- Works with SuperHitch Towing Series and more
- Legendary Lifetime Warranty
- Proudly made in the USA

YEAR	MODEL (CAB TYPE)	ITEM DESCRIPTION	MFG#
Any	Genesis	Fits any front/rear 2" receiver - Class III or higher	A7760

For ordering, detailed product descriptions and footnotes see torklift.com. Applications added daily.



Contact Us
800.246.8132 Toll Free
www.torklift.com Web

Legendary Lifetime Warranty
We stand behind our products.
Everytime.

Towing HEAVY DUTY

SuperHitch Original 17K



Features and Benefits

- 1,700 lbs tongue weight/ 17,000 lbs tow when used with weight distribution
- Highest ratings in the industry
- No-drill applications
- Double stacked 2"x2" upper and lower receiver†
- High penetration dual shield welding
- Same capacity in upper and lower receiver
- Reinforced hitch pin locations to prevent common elongation wear known as "egging"
- Three piece assembly for easier installation
- Hitch pins included
- Legendary Lifetime Warranty
- Proudly made in the USA

For ordering, detailed product descriptions and footnotes see torklift.com. Applications added daily.

†D1102 and D1104 use the factory hitch as the upper receiver.



Contact Us
800.246.8132 Toll Free
www.torklift.com Web

Legendary Lifetime Warranty
We stand behind our products.
Everytime.

Towing MAGNUM DUTY

SuperHitch Magnum 30K



Features and Benefits

- 3,000 lbs tongue weight/ 30,000 lbs tow when used with weight distribution
- Highest ratings in the industry
- No-drill applications
- 2.5"x2.5" upper receiver and 2"x2" lower receiver††
- High penetration dual shield welding
- Same capacity in upper and lower receiver
- Reinforced hitch pin locations to prevent common elongation wear known as "egging"
- Reducer sleeve included (for 2.5" receiver)
- Three piece assembly (for easier installation)
- Hitch pins included
- Legendary Lifetime Warranty
- Proudly made in the USA

For ordering, detailed product descriptions and footnotes see torklift.com. Applications added daily.

††D1102m and D1104m use the factory hitch as the upper receiver.

Due to this exception, the upper receiver may be 2" x 2" instead of 2.5" x 2.5." Call for details.



Contact Us
800.246.8132 Toll Free
www.torklift.com Web

Legendary Lifetime Warranty
We stand behind our products.
Everytime.

Towing WEIGHT DISTRIBUTING

SuperHitch Everest 30K



Features and Benefits

- 3,000 lbs tongue / 30,000 pull when used with SuperHitch Magnum
- Highest weight capacity available
- Unmatched safety
- Spring bar hook up clips available in both hydraulic assist and traditional styles (sold separately)
- Adjustable slide collars
- Hydraulic spring bar tension assist
- Highest ratings in the industry
- Legendary Lifetime Warranty
- Proudly made in the USA

ITEM DESCRIPTION	MFG#
Industry's highest ratings of 3,000lbs tongue weight and 30,000lbs towing	WD1000
Friction plate replacement kit: Prevents friction between yoke and ball mount.	WP1001
Separate set of hook up clips for hydraulic assist.	WP1002
Separate set of cam over leverage arms for engaging hook up clips	WP1003
Magnum Drop Shank - Everest only 30,000 lbs.	M9010
Magnum Drop Shank XL - Everest only 30,000 lbs.	M9011

For ordering, detailed product descriptions and footnotes see torklift.com. Applications added daily.



Contact Us
800.246.8132 Toll Free
www.torklift.com Web

Legendary Lifetime Warranty
We stand behind our products.
Everytime.

Towing BALLMOUNT ACCESSORIES

SuperHitch Ballmounts

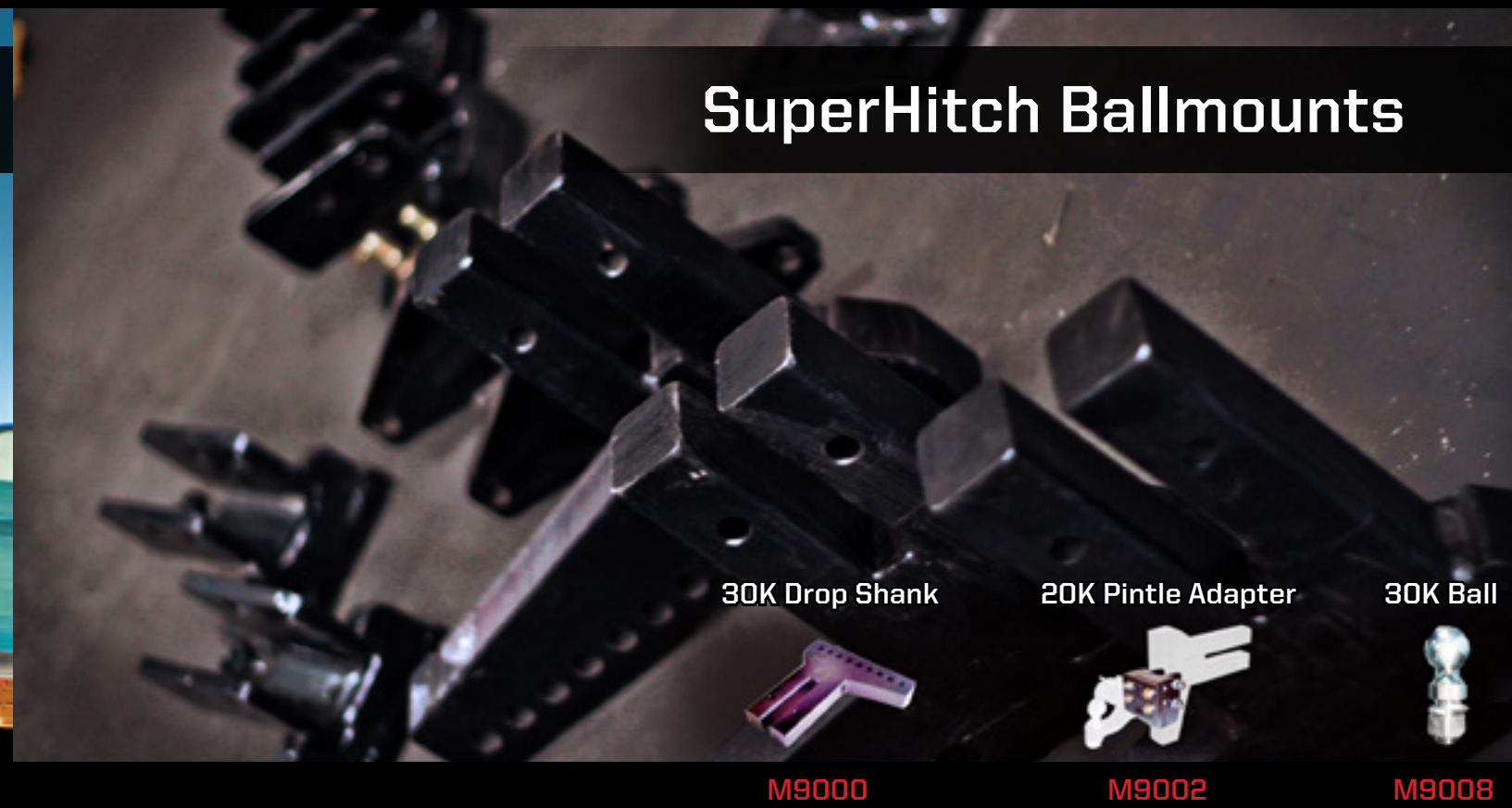

Features and Benefits

- For use with SuperHitch Towing Series and other hitches
- Designed for any heavy hauling applications: marine, RV, commercial, agricultural, etc.
- Highest rated ball mount accessories available
- Legendary Lifetime Warranty
- Proudly made in the USA

MODEL (CAB TYPE)	ITEM DESCRIPTION	MFG#
Magnum Drop Shank	30,000 lbs.	M9000
Magnum Drop Shank XL	30,000 lbs.	M9001
Magnum Ballmount Adapter	20,000 lbs.	M9005
Magnum Pintle Adapter	20,000 lbs.	M9002
Magnum Pintle Shank	17,000 lbs.	M9003
Magnum Ballmount Adapter	17,000 lbs.	M9004
Magnum 2.5" To 2" Adapter Sleeve	N/A	M9006
Magnum 30k Trailer Ball	30,000 lbs.	M9008
Magnum Drop Shank - Everest only	20,000 lbs.	M9010
Magnum Drop Shank XL - Everest only	20,000 lbs.	M9011

For ordering, detailed product descriptions and footnotes see torklift.com. Applications added daily.



Contact Us
800.246.8132 Toll Free
www.torklift.com Web

Legendary Lifetime Warranty
We stand behind our products.
Everytime.

Towing EXTENSION

SuperTruss Extension



Features and Benefits

- Designed for campers up to 12 feet
- Available in eight lengths from 21" to 60"
- Hardened reinforced hitch pin locations
- Optional SkidWheel available
- Highest capacity in the industry (12k lbs @ 48")
- Uses patented, lateral-support safety chains
- Legendary Lifetime Warranty
- Proudly made in the USA

LENGTH	DEAD WEIGHT	WEIGHT DISTRIBUTING	MFG#
21"	750 / 7,500	1,400 / 14,000	E1521
24"	750 / 7,500	1,400 / 14,000	E1524
28"	750 / 7,500	1,200 / 12,000	E1528
32"	650 / 6,500	1,200 / 12,000	E1532
36"	650 / 6,500	1,200 / 12,000	E1536
42"	600 / 6,000	1,200 / 12,000	E1542
48"	600 / 6,000	1,200 / 12,000	E1548
60"	500 / 5,000	1,000 / 10,000	E1560

SuperTruss Extension SkidWheel A7100

For ordering, detailed product descriptions and footnotes see torklift.com. Applications added daily.



Contact Us
800.246.8132 Toll Free
www.torklift.com Web

Legendary Lifetime Warranty
We stand behind our products.
Everytime.

Towing WIRING HARNESS

No-Splice Wiring Harness



Features and Benefits

- Various lengths for use with receiver extensions and 5th wheels
- 3-way harness allows you to run camper and trailer from factory truck plug
- Uses standard 7-pin RV plugs
- Proudly made in the USA

LENGTH	PRODUCT DESCRIPTION	TYPE	MFG#
24"	7-pin wiring pigtail for 21" extension	A	W6021
28"	7-pin wiring pigtail for 24" extension	A	W6024
32"	7-pin wiring pigtail for 28" extension	A	W6028
38"	7-pin wiring pigtail for 32" extension	A	W6032
42"	7-pin wiring pigtail for 36" extension	A	W6036
48"	7-pin wiring pigtail for 42" extension	A	W6042
57"	7-pin wiring pigtail for 48" extension	A	W6048
68"	7-pin wiring pigtail for 60" extension	A	W6060
120"	7-pin universal fit Truck-to-camper wiring harness	A	W6510

LENGTH	PRODUCT DESCRIPTION	TYPE	MFG#
120"	7-pin wiring pigtail for camper and trailer Fits 21"-28" extension	B	W6524
120"	7-pin wiring pigtail for camper and trailer Fits 32"-36" extension	B	W6532
120"	7-pin wiring pigtail for camper and trailer Fits 42"-48" extension	B	W6548

For ordering, detailed product descriptions and footnotes see torklift.com.



Contact Us
800.246.8132 Toll Free
www.torklift.com Web

Legendary Lifetime Warranty
We stand behind our products.
Everytime.

SUSPENSION



StableLoad

Features and Benefits

- The lowest cost, most effective suspension upgrade available
- Dramatically improves safety and handling by reducing sway and body roll
- Available in Quick Disconnect (engages and disengages in seconds)
- Anti-rotation key tabs
- Lower air bag pressure
- Quick, no-drill installation available
- Kit includes: Four StableLoads (outfits one truck)
- Legendary Lifetime Warranty: extends to the vehicle leaf spring
- Proudly made in the USA

Fits for:



For ordering, detailed product descriptions and footnotes see torklift.com. Applications added daily.

TORKLIFT
INTERNATIONAL
OVER 35 YEARS OF INNOVATION, QUALITY, SAFETY.

Contact Us
800.246.8132 Toll Free
www.torklift.com Web

Legendary Lifetime Warranty
We stand behind our products.
Everytime.

Auxiliary BATTERY STORAGE



HiddenPower New

Features and Benefits

- Add additional batteries under your truck bed
- Becomes an extension of your RV batteries and recharges via your RV solar panels, generator, converter etc.
- Securely clamps to truck frame
- Hidden when in use
- No drill installation
- Works with group 24 to 31 batteries
- Kit Includes frame mount bracket, group 24 to 31 battery box and installation hardware
- Legendary Lifetime Warranty
- Proudly made in the USA

PRODUCT DESCRIPTION	MFG#
1973-2007 Ford F250/F350 Long Bed Only (Without Battery Box)	A7703
1973-2007 Ford F250/F350 - Long Bed Only With Battery Box	A7727
2008-2012 Ford F250/F350/F450 - Long Bed Only With Battery Box	A7728
2001-2010 Chevy/GMC 2500/3500 - Ext. & Crew Long Bed / Crew Short Bed	A7730
2011-2013 Chevy/GMC 2500/3500 - Ext. & Crew Long Bed	A7732
1994-2002 Dodge 1500/2500/3500 Quad Cab Long Bed With Battery Box	A7742
2003-2009 Dodge 2500/3500 - Quad Cab Long Bed	A7740
2006-2013 Dodge 2500/3500 - Mega Cab Short & Long Bed	A7740
2009-2013 Dodge 2500/3500 - Crew Cab Long Bed	A7740

For ordering, detailed product descriptions and footnotes see torklift.com. Applications added daily.

TORKLIFT
INTERNATIONAL
OVER 35 YEARS OF INNOVATION, QUALITY, SAFETY.

Contact Us
800.246.8132 Toll Free
www.torklift.com Web

Legendary Lifetime Warranty
We stand behind our products.
Everytime.

Auxiliary BATTERY STORAGE



ExtendedPower **New**

Two ExtendedPowers shown

Features and Benefits

- Becomes an extension of your RV batteries and recharges via your RV solar panels, generator, converter etc.
- Kept constantly charged and RVing-ready by your truck's charging system.
- No-drill / easy install
- Attaches and detaches quickly for battery service
- Height adjustable
- Universal applications for all receiver extensions
- Lockable
- Works with group 24 batteries
- Designed for all types of batteries: lead acid, AGM, sealed, gel cell, etc.
- Kit Includes: extension receiver mount, group 24 battery box, two quick disconnect pins, security lanyard, lock and two keys
- Legendary Lifetime Warranty
- Proudly made in the USA

PRODUCT DESCRIPTION	MFG#
Works with Group 24 Batteries Only	A7735

For ordering, detailed product descriptions and footnotes see torklift.com. Applications added daily.



Contact Us
800.246.8132 Toll Free
www.torklift.com Web

Legendary Lifetime Warranty
We stand behind our products.
Everytime.

GlowStep Series GLOWSTEP



GlowStep

Features and Benefits

- Glows in the dark for 10 hours with only 5 minutes of light exposure
- Safely enter and exit your RV after dark
- SureGrip™ step tread - no grip tape
- Stores in position
- Lockable (lock sold separately)
- Exclusive: adjusts to basement model campers
- 100% aluminum and stainless steel
- Stainless bolted hinges allow for easy step addition or removal
- Legendary Lifetime Warranty
- Proudly made in the USA

PRODUCT DESCRIPTION	6" STEP TREAD DEPTH	8" STEP TREAD DEPTH
GlowStep - Add-a-Step	A7501	A7801
GlowStep - 2 Step	A7502	A7802
GlowStep - 3 Step	A7503	A7803
GlowStep - 4 Step	A7504	A7804
GlowStep - 5 Step	A7505	A7805
GlowStep - 6 Step	A7506	A7806

For ordering, detailed product descriptions and footnotes see torklift.com. Applications added daily.



Contact Us
800.246.8132 Toll Free
www.torklift.com Web

Legendary Lifetime Warranty
We stand behind our products.
Everytime.

GlowStep Series GLOWGUIDE



GlowGuide

- Handrail allows for safe entry and exit of RV
- Ultra lightweight (44 ounces)
- Glows for up to 10 hours
- From in-use to storage in seconds
- Handrail arms telescope from 32" to 53"
- Locks to your RV (lock sold separately)
- Universal mounting brackets
- Doubles as a wash brush
- Proudly made in the USA



Doubles as a washbrush

Features and Benefits

PRODUCT DESCRIPTION	MFG#
GlowGuide	A7600
RV GlowGuide	A7610
GlowGuide Brush	A7601

GLOWSTEP CAPACITIES	6" STEP TREAD DEPTH	8" STEP TREAD DEPTH
2-4 Step	325lbs	350lbs
5-6 Step	275lbs	300lbs

GLOWSTEP CAPACITIES WHEN USED WITH A GLOWGUIDE	6" STEP TREAD DEPTH	8" STEP TREAD DEPTH
2-4 Step	350lbs	375lbs
5-6 Step	300lbs	325lbs

For ordering, detailed product descriptions and footnotes see torklift.com. Applications added daily.



Contact Us
800.246.8132 Toll Free
www.torklift.com Web

Legendary Lifetime Warranty
We stand behind our products.
Everytime.

GlowStep Series SAFESTEP



SafeStep

New

Features and Benefits

- Barrier prevents injury from falling through open steps for children and pets
- Stays attached to steps in the stored position
- Velcro attachment
- Can be used with most steps
- UV protected for outdoor use
- Durable construction
- Removal is not necessary when stored
- Easy to clean
- Kit includes three SafeStep panels
- Proudly made in the USA

PRODUCT DESCRIPTION	MFG#
SafeStep Panels	A7602

For ordering, detailed product descriptions and footnotes see torklift.com. Applications added daily.



Contact Us
800.246.8132 Toll Free
www.torklift.com Web

Legendary Lifetime Warranty
We stand behind our products.
Everytime.

GlowStep Series DIRT DESTROYER



DirtDestroyer **New**

Features and Benefits

- Easy way to prevent muddy RV interior
- Quick clip on and off tool free design
- Easy to clean
- Legendary Lifetime Warranty
- Proudly Made in the USA

PRODUCT DESCRIPTION

Dirt Destroyer

MFG#

A7603

For ordering, detailed product descriptions and footnotes see torklift.com. Applications added daily.



Contact Us
800.246.8132 Toll Free
www.torklift.com Web

Legendary Lifetime Warranty
We stand behind our products.
Everytime.

GlowStep Series ACCESSORIES



Basement Camper Step

- Safe basement model truck camper access
- Attaches to all truck camper bumpers
- Eliminates "step up" gap between camper bumper and entry door
- Quickly folds up and down for basement door access
- Dimensions : 20" x 6" Step Rise: 7.8" collapsed

PRODUCT DESCRIPTION

Basement Camper Step - Powder Coat White

MFG#

A7510

Basement Camper Step - Aircraft Grade Aluminum

A7512



Locks

- Locks are keyed alike for convenience
- Features a snap lock design
- Quick and easy lock and unlock
- Includes weather caps to prevent weather damage and road grime.

PRODUCT DESCRIPTION

GlowStep Series Lock

MFG#

A7509

Spare GlowStep Brackets



- Allows for GlowStep placement on multiple applications
- For face mount or bottom mount

PRODUCT DESCRIPTION

Universal Mounting Bracket

MFG#

A7604

For ordering, detailed product descriptions and footnotes see torklift.com. Applications added daily.



Contact Us
800.246.8132 Toll Free
www.torklift.com Web

Legendary Lifetime Warranty
We stand behind our products.
Everytime.

SECURITY



PowerArmor **New**

Features and Benefits

- Designed to securely store batteries and trailer hitch parts, camping gear, etc.
- Prevent common and expensive storage/battery theft
- Dual use for securing batteries and other gear
- Bolts to your RV, camper bumper, truck, van etc.
- Heavy gauge diamond plate aluminum
- Unique slide top for easy storage access
- Comes in bright tread diamond plate and black powder coat diamond plate
- Easy to clean
- Legendary Lifetime Warranty
- Proudly made in the USA

ITEM DESCRIPTION	DIMENSIONS	MFG#
PowerArmor DH bright tread diamond plate (6 & 12-volt)	26 1/2"x7 15/16"x12 15/16"	A7706
PowerArmor DH high impact powder-coat black diamond plate (6 & 12-volt)	26 1/2"x7 15/16"x12 15/16"	A7708
PowerArmor DH bright tread diamond plate (12-volt)	24" x 7 15/16" x 10 5/16"	A7711
PowerArmor DH high impact powder-coat black diamond plate (12-volt)	24" x 7 15/16" x 10 5/16"	A7712
PowerArmor MAX bright tread diamond Plate (6 & 12-volt)	58 1/2"x 7 15/16"x12 15/16"	A7709
PowerArmor MAX high impact powder-coat black diamond plate (6 & 12-volt)	58 1/2"x 7 15/16"x12 15/16"	A7710

For ordering, detailed product descriptions and footnotes see torklift.com. Applications added daily.



Contact Us
800.246.8132 Toll Free
www.torklift.com Web

Legendary Lifetime Warranty
We stand behind our products.
Everytime.

SECURITY



Lock and Load **New**

Features and Benefits

- Allows expensive generators and other motorized equipment to be secure under lock and key and be fully functional for use without removal from Lock and Load tray
- Protect costly generators, welders, plasma cutters and more from theft
- Works with tool boxes, camping gear and more
- Mounts easily into front and rear receiver hitches
- Fits most generators
- Cargo tray dimensions: 28" x 23"
- Lockable
- Maximum security strap adjusts to secure objects from 8.5" x 13" x 13" to 28" x 22" x 23"
- Available in high impact powder coat steel
- Kit includes: cargo tray, heavy duty lock, adjustable maximum security strap
- Legendary Lifetime Warranty
- Proudly made in the USA

PRODUCT DESCRIPTION	MFG#
Lock and Load Security Tray	A7750
Spare Maximum Security Strap	A7751

For ordering, detailed product descriptions and footnotes see torklift.com. Applications added daily.



Contact Us
800.246.8132 Toll Free
www.torklift.com Web

Legendary Lifetime Warranty
We stand behind our products.
Everytime.

SECURITY



Fortress GasLock

Features and Benefits

- Allows tanks to be securely locked when mounted to trailers, towables and RVs
- Only lock available for propane tanks in the industry
- No tools, no modifications, installs in seconds
- Affordable investment
- Fits 3/8" and 1/2" threaded rods
- High impact military grade aluminum
- Proudly made in the USA



PRODUCT DESCRIPTION	MFG#
Fortress GasLock 3/8"	A7701
Fortress GasLock 1/2"	A7702
(AirStream) Fortress GasLock 1/2"	A7770

MFG#
A7701
A7702
A7770



For ordering, detailed product descriptions and footnotes see torklift.com. Applications added daily.



Contact Us
800.246.8132 Toll Free
www.torklift.com Web

Legendary Lifetime Warranty
We stand behind our products.
Everytime.

TRUE Frame Mounted TIE DOWNS



Tie Downs

Features and Benefits

"#1 tie down system"
-2012 Lance Owners of America survey

Steel Tie Downs

- Our tie downs become part of the truck foundation: THE FRAME
- Fast, no-drill installations (most)
- No loss of ground clearance
- Hidden when not in use
- Best ride quality in the industry
- Small truck applications
- Legendary Lifetime Warranty
- Proudly made in the USA

Aluminum Tie Downs

- Available for best-selling applications
- Rust proof
- Ultra-light weight
- Fast, no-drill installations
- No loss of ground clearance
- Hidden when not in use
- Best ride quality in the industry
- Legendary Lifetime Warranty
- Proudly made in the USA

Our TRUE Frame Mounted Tie Downs are available for Ford, Dodge, Chevy/GMC, Toyota and Nissan vehicles. For more information and application guides, please visit torklift.com. Applications added daily.

Tie Down Cover Finishing Kit

PRODUCT DESCRIPTION	MFG#
Tie Down Cover Finishing Kit	A7009

For ordering, detailed product descriptions and footnotes see torklift.com. Applications added daily.



Contact Us
800.246.8132 Toll Free
www.torklift.com Web

Legendary Lifetime Warranty
We stand behind our products.
Everytime.

TURNBUCKLES



- Kit includes two turnbuckles



FastGun - Long Range (25"-43")

- No. 1 selling truck camper turnbuckle
- 100% tool free
- 100% lockable
- 100% aircraft grade aluminum & stainless steel
- Spring tension indicators
- Legendary Lifetime Warranty
- Proudly made in the USA

PRODUCT DESCRIPTION	MFG#
Stainless Steel Powder Coated Grey	S9522
Stainless Steel Powder Coated White	S9523
Stainless Steel Polished	S9526
Stainless Steel Powder Coated Black	S9529
Turnbuckle Locks - (four locks)	S9500

FastGun - Short Range (14.5"-21.5")

PRODUCT DESCRIPTION	MFG#
Stainless Steel Powder Coated Grey	S9520
Stainless Steel Powder Coated White	S9521
Stainless Steel Polished	S9527



- Kit includes two turnbuckles

Springload XL

- High impact powder coated stainless steel
- Reaches from 28" to 43"
- Spring tension indicators
- Can be used with Derringer Handles
- Legendary Lifetime Warranty
- Proudly made in the USA

PRODUCT DESCRIPTION	MFG#
Springload XL	S9050A



- Kit includes two SpringLoad units, two heavy duty forged steel turnbuckles and chain

Basic Springload

- Forged steel
- Simple and affordable spring-loaded turnbuckle
- Can be used with Derringer Handles
- Legendary Lifetime Warranty
- Proudly made in the USA

PRODUCT DESCRIPTION	MFG#
Basic Springload Kit	S9000

For ordering, detailed product descriptions and footnotes see torklift.com. Applications added daily.

TURNBUCKLES



- Kit includes four handles



- Kit includes four quick disconnect Derringer Handles, two front spring-loaded turnbuckles 18.5" - 25.5" reach, and two rear cushioned turnbuckles 28.5" - 34.5" reach



- Kit includes two front spring-loaded turnbuckles 16.5" - 23.5" reach and two rear cushioned turnbuckles 31" - 34.25" reach

For ordering, detailed product descriptions and footnotes see torklift.com. Applications added daily.

Derringer Handle

- Quick disconnect handles
- Works with all turnbuckles
- Aircraft grade aluminum
- Secures with FastGun locks
- Legendary Lifetime Warranty
- Proudly made in the USA

PRODUCT DESCRIPTION	MFG#
Derringer Handle	S9528
Turnbuckle Locks (four locks)	S9500

AnchorGuard Derringer

- 100% aircraft grade aluminum & stainless steel
- Spring tension indicators
- Secures with FastGun locks
- Legendary Lifetime Warranty
- Proudly made in the USA

PRODUCT DESCRIPTION	MFG#
AnchorGuard Derringer (used for bed mounted tie down)	S9020
Turnbuckle Locks (four locks)	S9500

AnchorGuard

- Superior craftsmanship
- Highest quality bed mounted turnbuckle available
- 100% stainless steel and aircraft grade aluminum
- Spring tension indicators
- Can be used with Derringer Handle
- Legendary Lifetime Warranty
- Proudly made in the USA

PRODUCT DESCRIPTION	MFG#
AnchorGuard	S9013

Storage & STABILITY



FastGun Wobble Stopper

Features and Benefits

- Dramatically reduces camper jack and frame stress
- Quick Disconnect handle uses FastGun technology
- Lockable, keyed-alike locks included
- Prevents truck camper theft
- High impact powder coat white
- Round and square jack applications
- Easy DIY bolt on installation
- Halts chassis movement
- Stores to the camper jacks
- Stabilizes truck camper and prevents movement
- 100% aircraft grade aluminum and stainless steel
- Legendary Lifetime Warranty
- Proudly made in the USA

PRODUCT DESCRIPTION

FastGun Wobble Stopper Round Bracket
 FastGun Wobble Stopper Square Bracket
 Wobble Stopper Round Bracket
 Wobble Stopper Square Bracket

MFG#

A7006
 A7016
 A7005
 A7015

For ordering, detailed product descriptions and footnotes see torklift.com. Applications added daily.



Contact Us
 800.246.8132 Toll Free
www.torklift.com Web

Legendary Lifetime Warranty
 We stand behind our products.
 Everytime.

Storage & STABILITY



Camper Packer New

Features and Benefits

- Safe, long-term storage
- Dramatically reduces jack and camper frame stress
- Rated at 6,000 lb. capacity per pair*
- 5 year warranty
- Kit includes high impact powder coat brackets, fasteners and treated lumber
- Easy assembly
- Measures 50" from side-to-side when completely assembled
- Affordable storage solution
- Proudly made in the USA



PRODUCT DESCRIPTION

Camper Packer - lumber included

MFG#

A7012

For ordering, detailed product descriptions and footnotes see torklift.com. Applications added daily.



Contact Us
 800.246.8132 Toll Free
www.torklift.com Web

Legendary Lifetime Warranty
 We stand behind our products.
 Everytime.

Torklift International DISPLAYS

FastGun POP Display

- Display Features any combinations of part numbers by request
- #1 best selling part number
- Up to 12 billable labor hours per box
- Free when you order the product inside
- Easy set up, recyclable when product is gone
- Add this salesman to your team



StableLoad POP Display

- Display Features any combinations of part numbers by request
- Up to 12 billable hours per box
- #2 best selling part number
- Free when you order the product inside
- Easy set up, recyclable when product is gone
- Add this salesman to your team

Torklift International DISPLAYS

GlowStep Display Frame

- Designed to display the GlowStep / GlowGuide
- Customers can now see and feel the difference
- Easy assembly
- Small footprint
- Customers can experience the strength and sturdiness of these products first hand



SuperHitch Display Frame

- Displays a SuperHitch & SuperTruss Extension or SuperHitch Magnum & SuperTruss Extension or SuperHitch Hero & SuperTruss Extension
- Freestanding display
- Displayed product can also be installed directly on your customer's vehicle

For ordering, detailed product descriptions and footnotes see torklift.com. Applications added daily.

For ordering, detailed product descriptions and footnotes see torklift.com. Applications added daily.

Torklift International DISPLAYS

3 x 4 Full Torklift Display Frame

- The full Torklift line on one clear display
- Attaches to showroom wall



StableLoad Counter Display

- Information on the StableLoad
- Working display with StableLoads
- Fits on counter or hangs on wall



Brochures and Posters

Free*, contact us for details



Torklift International Brochure



SuperHitch Towing Series Poster



FastGun Series Poster

For ordering, detailed product descriptions and footnotes see torklift.com. Applications added daily.



Contact Us
800.246.8132 Toll Free
www.torklift.com Web

Legendary Lifetime Warranty
We stand behind our products.
Everytime.

Torklift International DISPLAYS

Fortress GasLock Poster Display

- Post in front of your propane fill station
- Inform customers about propane safety



Fortress GasLock Peg Board Display

- Simple to install
- Easily illustrate the benefits of protecting propane tanks from theft



Torklift Banner

- 4" x 8" Banner
- Informs customers that you are a Torklift Certified Dealer
- Free upon certification

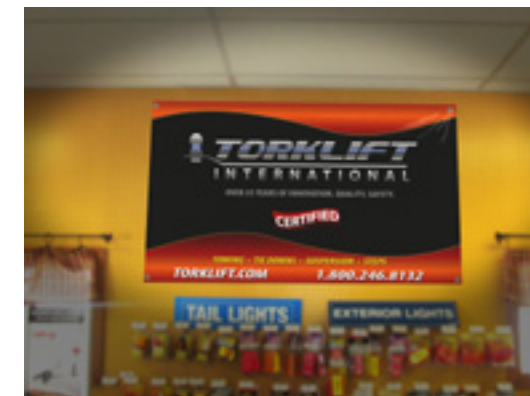

Truck Camper Counter Display Card

- Shows truck camper products on one clear display
- Small size allows for versatile display



For ordering, detailed product descriptions and footnotes see torklift.com. Applications added daily.



Contact Us
800.246.8132 Toll Free
www.torklift.com Web

Legendary Lifetime Warranty
We stand behind our products.
Everytime.

Torklift International CERTIFIED DEALER

BECOME A TORKLIFT CERTIFIED DEALER More Perks, More Benefits, More Everything!

- **TOP BILLING FOR CUSTOMER REFERRALS** Torklift Certified Dealers are always referred to first because they are the best trained dealers on our products.
- **PRODUCTS FOR DEMO VEHICLE** The best way to show customers our product is to have them installed.
- **ON-GOING TRAINING** Stay up to date on the latest Torklift International products to help your customers.
- **NATIONAL BRAND RECOGNITION** Torklift International is a household name your dealership can be synonymous with.
- **TORKLIFT GEAR** We will send you Torklift banners, hats, and promotional gear to help build customer relationships.
- **SPECIAL RECOGNITION ON TORKLIFT.COM** Each month we feature a different Certified Dealer on our home page. We'll send new customers into your dealership.

TO QUALIFY FOR OUR DEALER CERTIFICATION PROGRAM

- Attend the convenient online virtual training
- Take the online test
- Pass the test
- Become a Torklift Certified Dealer and see what you've been missing



Torklift International SPONSORSHIP



Holly Clarke
Drag Racer



Gear

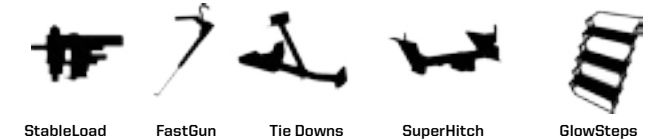

Byron Haner
Champion Sled Puller



Gear



James Niggemeyer
Professional Bass Fisherman



Gear

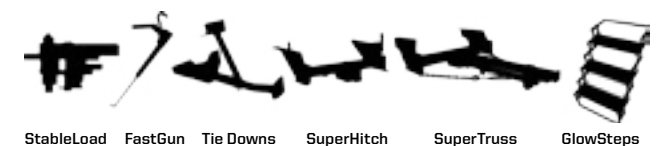

Torklift International CONTACT US

MAILING ADDRESS: 1901 Fryar Ave, Sumner, WA 98390

MAIN OFFICE NUMBER: (800) 246-8132

FAX NUMBER: 253-854-8003

GENERAL MANAGER

JAY TAYLOR

EMAIL - jayt@torklift.com

NATIONAL SALES MANAGER

RANDY FISHER

EMAIL - randyf@torklift.com

CUSTOMER SERVICE MANAGER/PURCHASER

LENA KOSTENKO

EMAIL - lenak@torklift.com

SALES / TECHNICAL SUPPORT

MATT PICKERING/DARREL HAGGLUND

EMAIL - mattyp@torklift.com

EMAIL - darrelh@torklift.com

Sr. Vice President of Marketing

CANDICE BOUTILIER

EMAIL - candiceb@torklift.com

Feel free to visit us at our website, where you can find product information, local dealers and automated application guides.

www.torklift.com

Torklift International ORGANIZATIONS

TORKLIFT INTERNATIONAL

is a member of the following organizations.





1901 Fryar Ave
Sumner, WA 98390

800.246.8132

www.torklift.com

Torklift International. All Rights Reserved

