



Motorized Stair Climbers and LiftGates

Sales & Business Development,
LP International Inc. - PowerMate[®]
E-mail: sales@PowerMate.info
Toll Free: 1-800-697-6283
Fax: 519-759-3298

For more information, visit our web
site: www.PowerMate.info

Visit our NEW PowerMate[®] Blog
Today!



PowerMate[®] :
The Tools that make money!



Ask about our retractable dolly attachment!



PowerMate® StairClimbing HandTrucks **Is PowerMate® Right For You?**

Moving: Geothermals, Water Heaters, A/C's, Boilers, Furnaces, Bathtubs, Drain Cleaners, up and down stairs, on and off vehicles?

Looking for cost effective ways to increase productivity and efficiency?

Are safety and image priorities for your organization?

Are you concerned about potentially expensive lost time injuries or tired of paying unnecessary Worker's Compensation costs?

Are you dealing with a reduction in staff? An aging workforce?

Are you interested in how PowerMate® can make more Profit for your company?

If you answered yes to one or more of the above questions, there is a PowerMate® solution right for you!



PowerMate®

THE INDUSTRY STANDARD

Increase Safety

- ▶ Independent research finds: PowerMate® requires 87% less effort for the operator than a conventional hand truck
- ▶ Valuable tool as a piece of Personal Protective Equipment (PPE)
- ▶ Reduce injuries, lost work days and modified duty days
- ▶ Lower Worker's Compensation premiums - *U.S. Department of Labor quotes: \$29,000 as the average cost of a single lost time injury (direct & indirect costs).*

Lower Labor Costs

- ▶ Reduce labor costs by 50% or more (e.g. Use one person instead of two!)
- ▶ Potential to eliminate the need for additional helpers on larger jobs
- ▶ Eliminate curb side deliveries
- ▶ Increase employee retention and satisfaction

Decrease Product Damage

- ▶ Well-balanced – The operator has complete control at all times
- ▶ Heavy duty nylon reinforced straps with cotton overlay & adjustable felt protected strap bars to secure the load in place



*With PowerMate®, you are always in control.
You even have the unique ability to skip
missing, broken or suspect steps!*



THE INDUSTRY STANDARD (con't)

Decrease Property Damage

- ▶ Non-marking, puncture proof wheels and full length bottom rubber guard
- ▶ Reduce the risk of unnecessary and costly general liability claims
- ▶ Designed not to come into contact with the nose of the stairs
- ▶ Increase customer satisfaction - Create more repeat and referral business

Professionalism/Image

- ▶ Provide your customers with value-added delivery services at little or no cost
- ▶ Ability to deal efficiently with peak seasonal demand periods
- ▶ Best in class tool adds to “Red Carpet” image
- ▶ Differentiate your company from your competitors

Reliability

- ▶ Low maintenance, top of the line battery (4-7 years life).
- ▶ PowerMate[®] can pay for itself in months and lasts for years!
- ▶ State of the art materials and construction including; **NEW** - Solid state circuitry.
Just another example of how we deliver the lowest total cost of ownership –
Reduces battery draw, extends equipment life and simplifies servicing.

***PowerMate[®] :
Strong, Dependable &
Built to Last!***



Typical Savings Summary

Monthly Labor Savings Using a
PowerMate[®] = \$3,200.00

Potential Annual Savings
= \$38,400.00

Better than a 10:1 R.O.I. at the end of year 1!

PowerMate[®] Generates Revenue - Quick & Substantial
Return on Investment (R.O.I.)

PLUS: Avoid just one injury and potentially save
an average additional expense of **\$29,000!**



Call 1-800-697-6283 for your
FREE Savings Analysis!

Avoid Cost, Minimize Risk & Maximize PROFIT!

- Increase employee productivity, satisfaction and morale
- Increase employee retention - Keep and attract valuable long term employees
- Provide the opportunity to hire installers regardless of age, physical size or gender
- Get employees on modified duties back to work and productive
- At L P International Inc., our account management software not only tracks the machine but the operator too! This gives us the ability to provide you with value-added reporting
- Create more referrals and repeat business
- Send the message: *“We care about our people, your product and you - our valued customer.”*
- Can eliminate the need for a tailgate lift - avoid \$3,500-\$7,500 in additional cost
- Grow your business; become more price competitive and increase your margins



With a PowerMate®, you have the ability to leave the machine safely on flat surfaces, even on stairs, in a well-balanced position, to open doors, answer phone calls or remove safety hazards!



PowerMate® Model L-1

The PowerMate® L-1 is the perfect solution to moving residential hot water tanks, small A/C units, smaller geothermal units, specialty gas cylinders and furnaces on and off vehicles over thresholds and up and down stairs. Recommended load capacity 650 lbs.

Exclusive - Solid State Controls (no solenoids), further reducing the total cost of ownership and featuring “soft start” for safer and smoother operation.

Hardened steel drive screw and extruded aluminum construction for greater durability and strength.

Spring lock safety device in the ball nut and two switch operation with override provide additional drive system security and safety.

3 point break back system for full operator control.

Highly maneuverable in tight spaces.

Top of the line, maintenance free battery (4 - 7 year life).

Designed to protect stairs and floor surfaces of all kinds with full length bottom rubber guard and non-marking wheels.

Like all our machines; you have the ability to skip missing, broken or suspect steps!

Comes complete with: solid state controls, one strap bar, battery and battery charger.



NEW! Optional Retractable Dolly Attachment

Moving across flat surfaces just got easier with PowerMate®! The NEW L-Series retractable dolly attachment is compatible with other attachments including; our Rough Terrain Cart! (below)



PowerMate® Model LE-1

The only machine of its kind!

The PowerMate® LE-1 is perfect for moving water heaters, furnaces, geothermal units, pumps, boilers, generators, radiators, drain cleaning equipment, motors, compressors, and SEER rated A/C units on and off vehicles over thresholds and up and down stairs. Recommended load capacity 650 lbs.

Exclusive - Solid State Controls (no solenoids), further reducing the total cost of ownership and featuring “soft start” for safer and smoother operation.

Two drive screws allow for perfectly balanced loads and effortless deliveries, most with just one person! Unique design created for low center of gravity loads, including HVAC-R equipment. Vertical lift capability 40" (stacking) - Perfect for pedestals and wall mounts.

Smallest footprint and the most maneuverable machine in tight spaces.

Hardened steel drive screws and extruded aluminum construction for greater durability and strength.

With a push of a button you can change the fulcrum “on the fly”.

Spring lock safety device in the ball nut and two switch operation with override provide additional drive system security and safety.

Top of the line, maintenance free battery (4 - 7 year life).

The LE model comes complete with: solid state controls, two strap bars, hand operated wheel brakes, battery and battery charger.



Our customers tell us they can safely move more than our machines rated capacity with 50% of the manpower!



Optional Rough Terrain Cart

Perfect for: new construction sites, row housing, mud, grass, gravel, sand, water and snow!



The LE-1 Advantage

- 1. Vertical Lift / Stacker** - 40" Vertical lift capability (stacking), with no attachments. Perfect for pedestals and wall mounts!
- 2. The unique ability to shift the load “on the fly”** - The operator can change the position of the load while using the PowerMate[®] with a push of a button. By shifting the weight of the load (changing the fulcrum), the weight is taken off the operator making the move easier, even for a smaller person. This can be done even while the machine is in use, loading, stacking, dock leveling or climbing stairs and all with no attachments.
- 3. Smallest Footprint** - The most maneuverable machine in tight spaces, complete more installs and removals than ever before. The first drive screw allows you to climbing stairs, for example, using the second drive screw you can raise or lower the load on the fly to negotiate turns and avoid obstacles. All this with a push of a button!



PowerMate[®] LE-1: Shifting the load on the “fly”.

The LE-1 Advantage

4. Wheel Brakes - Hand operated wheel brakes come as standard on the PowerMate[®] LE-1. The wheel brakes are always deployed for greater operator control and safety. The brakes are only released when you depress the conveniently located lever control on the left-hand grip. The operator is always in control whether on flat surfaces, in vehicles, or climbing stairs.

5. Lowest Total Cost of Ownership - Solid State Controls (no solenoids), featuring “soft start” for safer and smoother operation, Top of the line, maintenance free battery (4 - 7 year life), Extruded aluminum construction, hardened steel drive screws...

6. 3 Point Break Back System: Raise the wheels 8-12", changing the fulcrum, and break the load back with one hand...no more putting your foot on the axle and pulling - the PowerMate[®] does the work for you!



All PowerMate[®] L & M Series machines including the LE-1, feature our “3 point break back” system.

PowerMate® M-Series Models

StairClimbing HandTrucks

The PowerMate® M-1 and M-2B are the perfect solutions for moving larger boilers, commercial hot water tanks, motors, compressors, generators as well as heat pumps and bathtubs on and off vehicles, up and down stairs.

Exclusive - Solid State Controls (no solenoids), further reducing the total cost of ownership and featuring “soft start” for safer and smoother operation.

Carries the load on the larger outer frame to increase stability and minimize frame twisting.

Hardened steel drive screw and steel frame construction for greater durability and strength.

Top of the line, maintenance free battery (4 - 7 year life).

Spring lock safety device in the ball nut and two switch operation with override provide additional drive system security and safety.

Unique 3 point break back system for full control, 100% of the time.

Designed to protect stairs and floor surfaces of all kinds with full length bottom rubber guard and non-marking wheels.

Comes complete with: solid state controls, built-in retractable dolly attachment, two strap bars, battery and battery charger.



Also available: M-2B - 8" taller than M-1 for consistently taller loads.
Both models have a 1,500 pound maximum recommended weight.



M-Series Wheel Brakes

Provides greater safety and further reduces operator effort!



PowerMate® "The PowerMate® SOLUTION"

StairClimbing HandTrucks



L-1 & Radiator



LE-1 & A/C Unit



M-1 & Oil Furnace



LE-1 & Cast Iron Boiler



M-1 & 700 lbs Boiler



LE-1 & Wood Stove



LE-1 & Boiler



L-1 & Water Heater with our Rough Terrain Cart



To view video of PowerMate® in action go to: www.PowerMate.info/

Residential Complete Moving Solution

Challenged with moving in tight spaces?

“World Class” Operator Training:

Invest in your people. Training is imperative to gain compliance and realize the full benefits of your investment. It's important to give your employees the right tools for the job - it's critical they know how to use them safely and effectively!

North American Operator Trainings are available five ways:

- Training Video and Manuals
- Training The Trainer Program
- On-line Instructional Training (Coming soon)
- Brantford, Ontario International Training Center
- Customer On-site Training

Exclusive! Step Extension and Small Pivot Pad

Perfect for small landings and tight turns, the stair extension and large pivot pad can be used at the top or bottom of stairs and to create space on tight landings. This accessory gives you the ability to complete 17% more installs and removals than ever before! Features: telescopic feet, adjustable to virtually any stair rise and run; light weight and requires minimal space on the delivery vehicle. Move your loads around tight corners while protecting your customer's product and property.



PowerMate® delivers the “smallest footprint”. Need to create space? Push a button to raise the wheels!



PowerMate[®]: Superior Customer Service

- Purchase a PowerMate[®] and you're automatically enrolled in our Ongoing PowerMate[®] Customer Care Program
- Service available 5 days a week during regular business hours.
Option: Service can be scheduled, on-site, even for weekends
- 24 hour turn around time on parts orders sent overnight courier
- Over five different operator training programs available to ensure compliance and your return on your investment
- Our 1-800 phone number is on all our machines and our qualified Customer Service Representatives are never more than a phone call away.
Even when, you or your people are on a job site!
- With PowerMate[®] you are always dealing with L P International Inc.
factory trained Technicians



Customer Testimonials

Don't just take our word for it!

We invite you to read what just a few of our many satisfied PowerMate® customers have to say about our products and services:

T WEBBER PLUMBING & HEATING

“ ... We purchased the L-1 model and it has been the perfect tool for getting water heaters, boilers, furnaces, and air conditioning condensers in and out of our customer's homes.

Since time is money in our business it has allowed us to get these heavy objects in and out of jobsites as quickly as possible. This has led to increased revenue and better job efficiency. Now instead of sending two technicians to move an old boiler or set one in place we only have to send one. Not only is management happy about this but the technicians are as well....”

GRANT HEATING AND COOLING

“We love our PowerMate!

The owner of our company was telling me that changing boilers was taking too much time. We needed 4 men to remove the old cast iron boilers. This meant taking 2 men from another job and have them help the other 2 mechanics remove the old boiler. It was taking us an additional 6 to 8 hours to remove a boiler! I told the owner to get us a PowerMate hand truck, then we could avoid sending two extra men to each boiler job. Business owners know that costs are fixed, but time is money!

We have since bought a PowerMate M-1 stair climbing hand truck. With the time we have saved, it has only taken a few small jobs to pay for itself. Not only that, it has greatly reduced the risk of injury to employees. The PowerMate hand truck was one of the best investments our company has made!”



PowerMate® StairClimbing HandTrucks Who is L P International Inc.?

- Manufacturer and Worldwide distributor of PowerMate® lifting products
- Occupy a new 35,000 square foot facility with adjacent real estate to accommodate growing demand
- Over 35 years of business expertise in safety moving systems
- Business is built on product value and customer relationships
- Partner with companies to assist in achieving their objectives creating a “Win-Win” situation
- Best in class operator training and post sales support

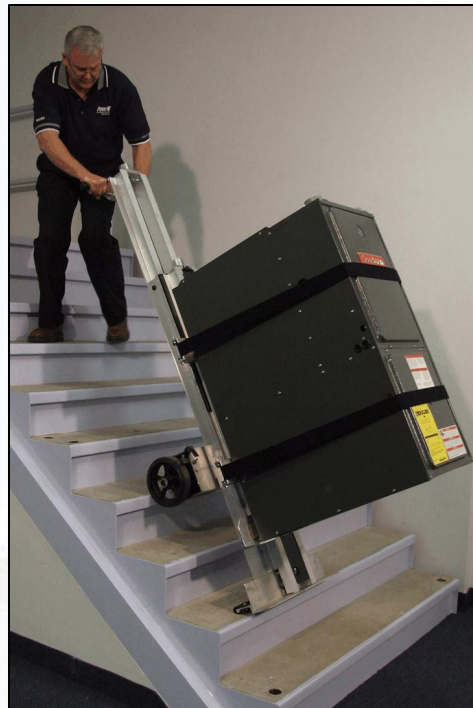

With our Flagship PowerMate® LE-1, you have the unique ability to change the position of the load with a push of a button...even while climbing stairs! That's just one of the advantages of having two drive screws!

NEXT STEPS...

To place your order TODAY or to discuss how best to implement your PowerMate[®] Program, Contact:

**Sales & Business Development,
L P International Inc. - PowerMate[®]**

E-mail: sales@PowerMate.info

Toll Free: 1-800-697-6283

URL: www.PowerMate.info

Upcoming Opportunities to see PowerMate[®] LIVE in 2012:



Booth #6746



Interested how a PowerMate[®] LiftGate can add to your bottom line? Read on...

Strong, Dependable & Built to Last!

Using full-sized vans, sprinter vans, trucks where the dimension from the ground to the bed of the vehicle is 40" or less?

Consider PowerMate® LiftGates...



PowerMate® LiftGates

The Worlds First Interior Tailgate Lift!

The PowerMate® LG-3 and LG-6 are the perfect compliments to many of our other machines or as a stand alone! Ideal for moving loads up to 500lbs on and off vehicles including; cube trucks and full-sized vans and sprinters.

Works from the vehicles electrical system

Articulated arm movement, position loads inside the vehicle, over the vehicle bumper and curbs

Installed 100% inside the vehicle - out of the weather

Minimal space required : 1.5 sq. ft. footprint

Regular tailgate lifts cost \$3.5K to \$7.5K, the PowerMate® LiftGates can save you more than 50%

Installation options: right and left side rear door, side door install also available. Position the LiftGate away from traffic and increase operator safety!

Decreases the size of parking space required-great for urban areas

Vehicle gross weight reduction versus, much heavier fold down exterior lifts

LiftGate installation: ONLY \$475.00 and completed in hours!



Liftgate Model LG-3

Specifications



- HEAVY DUTY STEEL AND ALUMINUM FRAME
- ARTICULATED ARM MOVEMENT FOR FLEXIBLE POSITIONING
- FULLY AUTOMATIC BRAKING SYSTEM
- SUPER EFFICIENT BALL SCREW DRIVE
- END STOP OVERRIDE CLUTCH
- ROCKER SWITCH (UP/DOWN) OPERATION
- GEAR REDUCED MOTOR
- OPERATES USING 12 VOLT VEHICLE ELECTRIC SYSTEM
- ADJUSTABLE STRAPBAR AND/OR CRADLE ATTACHMENT
- LOAD PROTECTIVE FELT
- HEAVY DUTY TOE PLATE
- OVERALL WEIGHT 211 LBS. (96kg)

| Model | LG-3 250 | | LG-3 500 | |
|--------------------------------------|---|-------------------------|---|-------------------------|
| Part Number | 480113 Left Handed 480213 Right Handed | | 482113 Left Handed 482213 Right Handed | |
| Lifting Height | 710 mm | 28" | 710 mm | 28" |
| Machine Capacity | 113 kg | 250 lbs | 227 kg | 500 lbs |
| Toe Plate Swing Distance | 900 mm | 35 3/8" | 900 mm | 35 3/8" |
| Foot Print (Excl. Toeplate) W x D | mm 660 x 343 | inches 26" x 13 1/2" | mm 660 x 343 | inches 26" x 13 1/2" |

Note: Many customers have their PowerMate® LiftGates included in their new vehicle acquisition (fleet) program, making their investment an operating expense and not a capital expense! Contact us for more information today!



PowerMate® LiftGates: Installation Options



PowerMate® LG-3B & Drain Cleaner



PowerMate® LG-6B & Residential Plumbing Vehicle

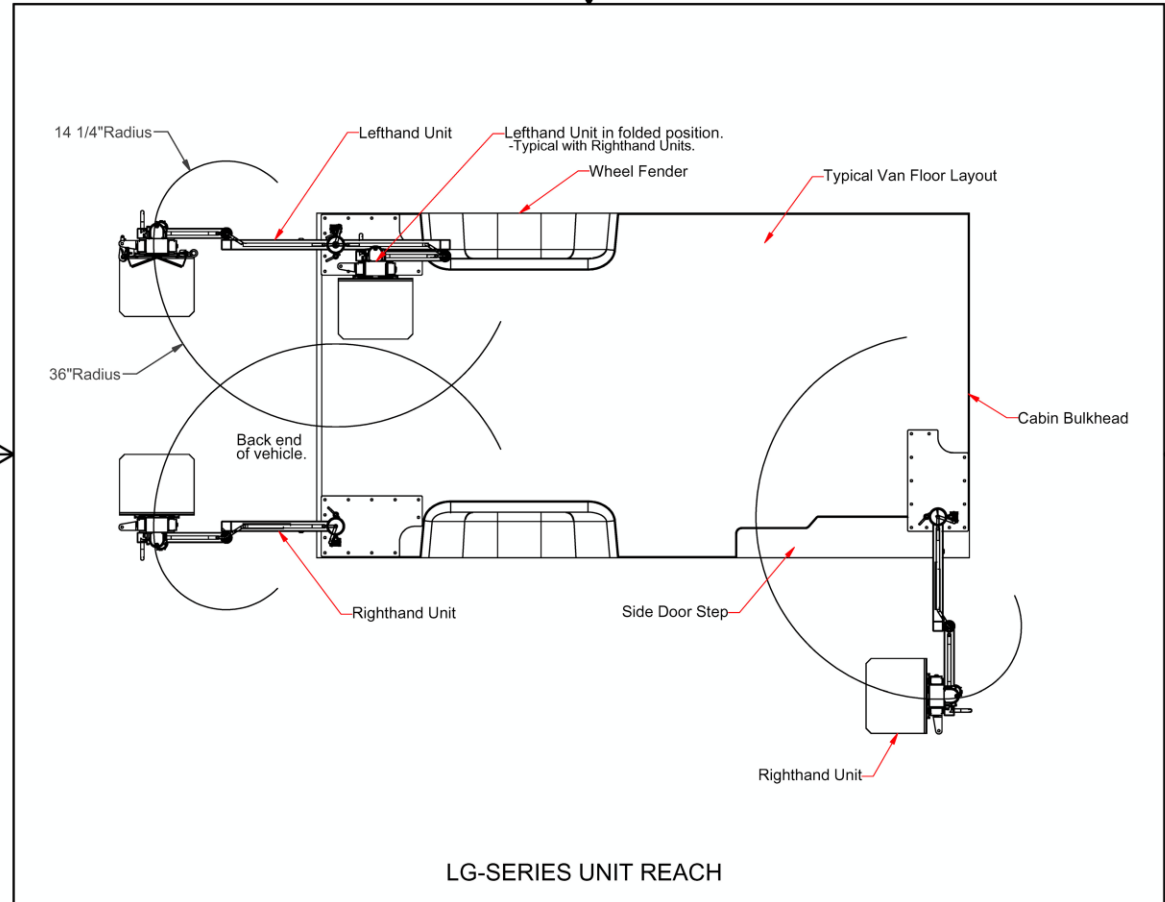

Upon request, PowerMate® can arrange for your LiftGate installation locally!



PowerMate® LiftGates: Space Requirements

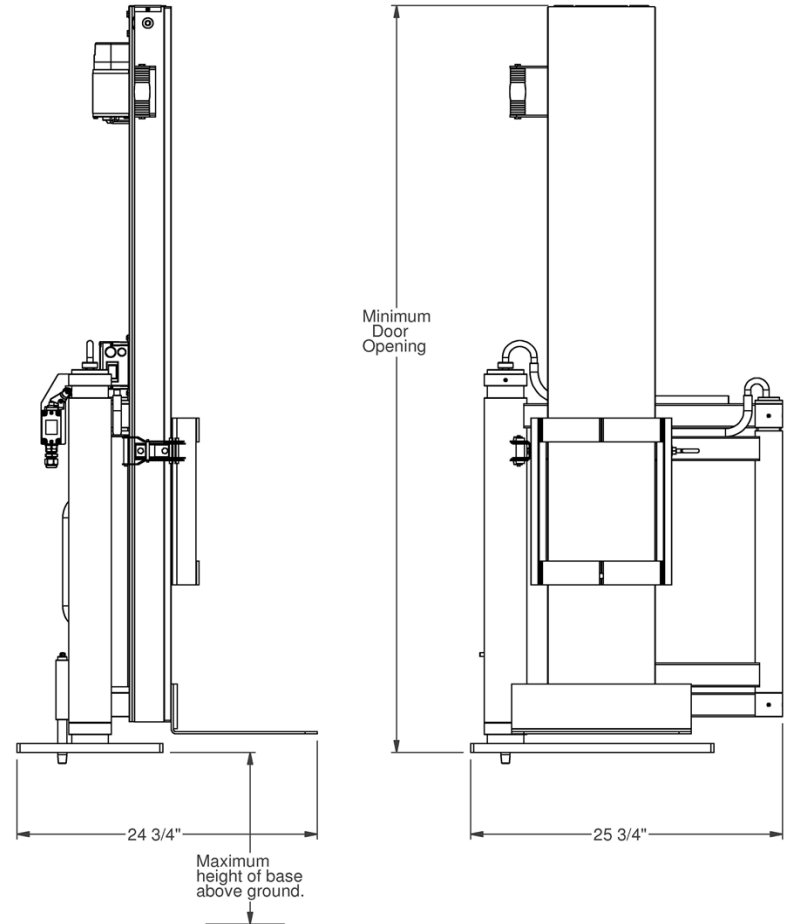

| LiftGate Model No. | Minimum Door Opening | Maximum Height of Base above ground. |
|--------------------|----------------------|--------------------------------------|
| LG-3 | 47 3/4" (1212mm) | 28" (711mm) |
| LG-5 | 59" (1498mm) | 36" (915mm) |
| LG-6 | 63" (1600mm) | 40" (1016mm) |

INSTALLATION DIMENSIONAL REQUIREMENTS

