

CINCINNATI®

STOCKED PRESS BRAKE DIES

Increase Your Profits with Precision Tooling

NO WAITING Phone your order today; we can ship within 72 hours.

MORE PARTS PER DIE Most of our precision dies are made of 80 to 90 high carbon brake die steel while large bars are from specially selected CINCINNATI die steel, heat-treated throughout, 245 to 290 Brinell. Each die is tough and wear resistant. They can be remachined without the necessity to anneal and reharden.

WIDEST SELECTION ANYWHERE We offer over 130 types; air bend, acute angle, bottoming, gooseneck, four-way, and flattening dies, in lengths from 25" to 194".

REDUCE REJECTS Our dies are machined to a smooth finish and close tolerances.

FIT MOST PRESS BRAKES All standard tongues are $\frac{5}{8}$ " height x $\frac{1}{2}$ " width.

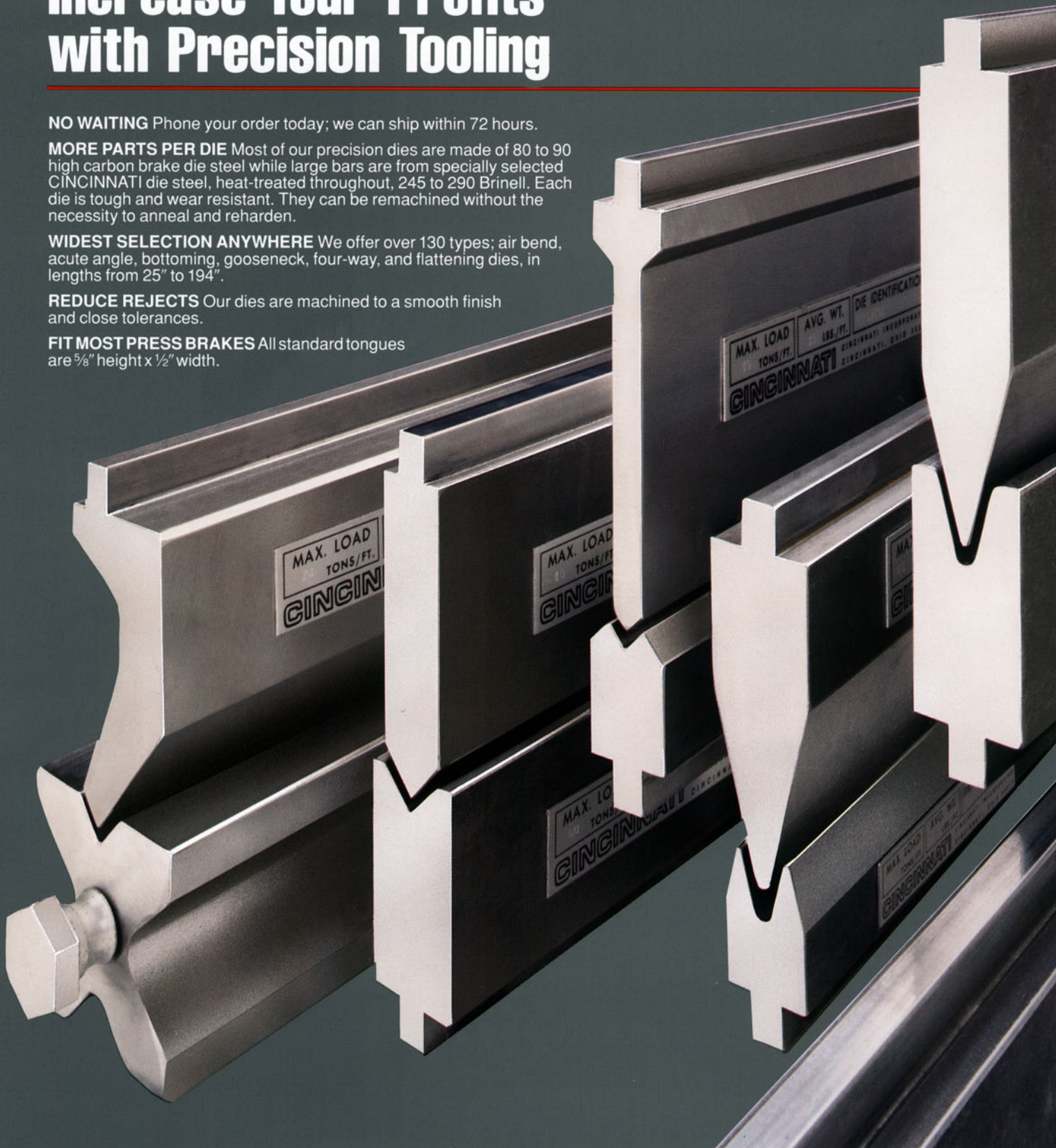

CINCINNATI

Stocked Press Brake Dies

DIE LENGTH CODES

B	D	F	H	K	M	P	R
25" (2'1")	49" (4'1")	73" (6'1")	97" (8'1")	122" (10'2")	146" (12'2")	170" (14'2")	194" (16'2")

All tongues are 5/8" high x 1/2" wide. "R" equals radius of nose of upper die and should not be confused with inside radius of angle formed by die. Capacity shown is for mild steel.

AIR BEND DIES

All included angles **85°** unless otherwise specified

Included angle for both upper and lower dies allows for overbending of metal to compensate for springback. Angles from very shallow to 90° are formed by adjusting the press brake ram.

If parts are to be formed with "air bend" dies on a press brake with controls that use mathematical models (i.e. AUTOFORM®) to determine ram reversal positions, the dies must be cut to a 75 degree or less angle to compensate for all possible material springback. In some cases, 30 degree dies can be selected to obtain true air bending of 90 degree angles.

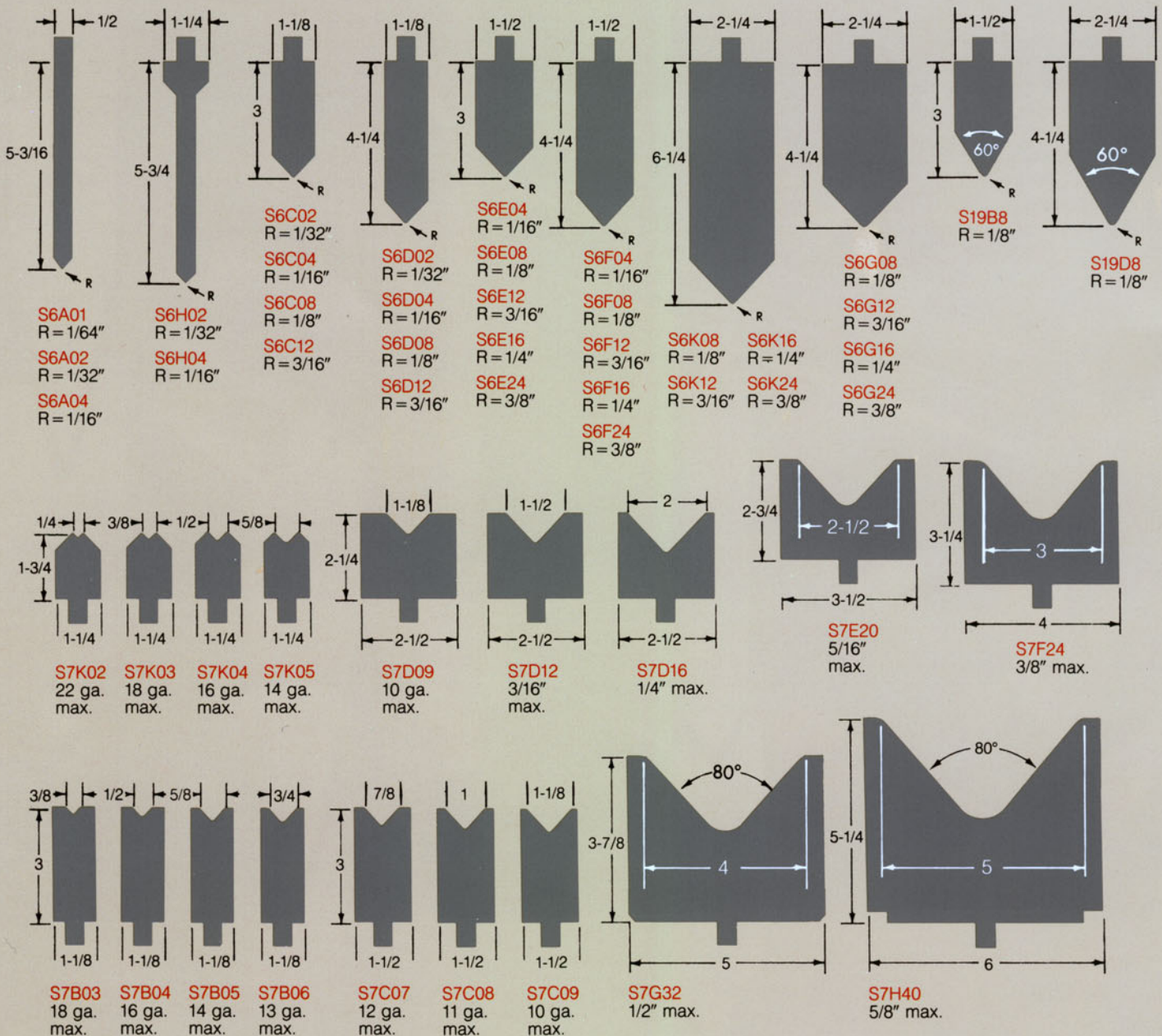

ACUTE ANGLE DIES

All included angles **30°**

Acute angle dies are used for air bends from very shallow angles to 30 degree angles. The angle formed depends on the depth to which the upper die enters the lower die. Acute angle dies are commonly used to preform hems.

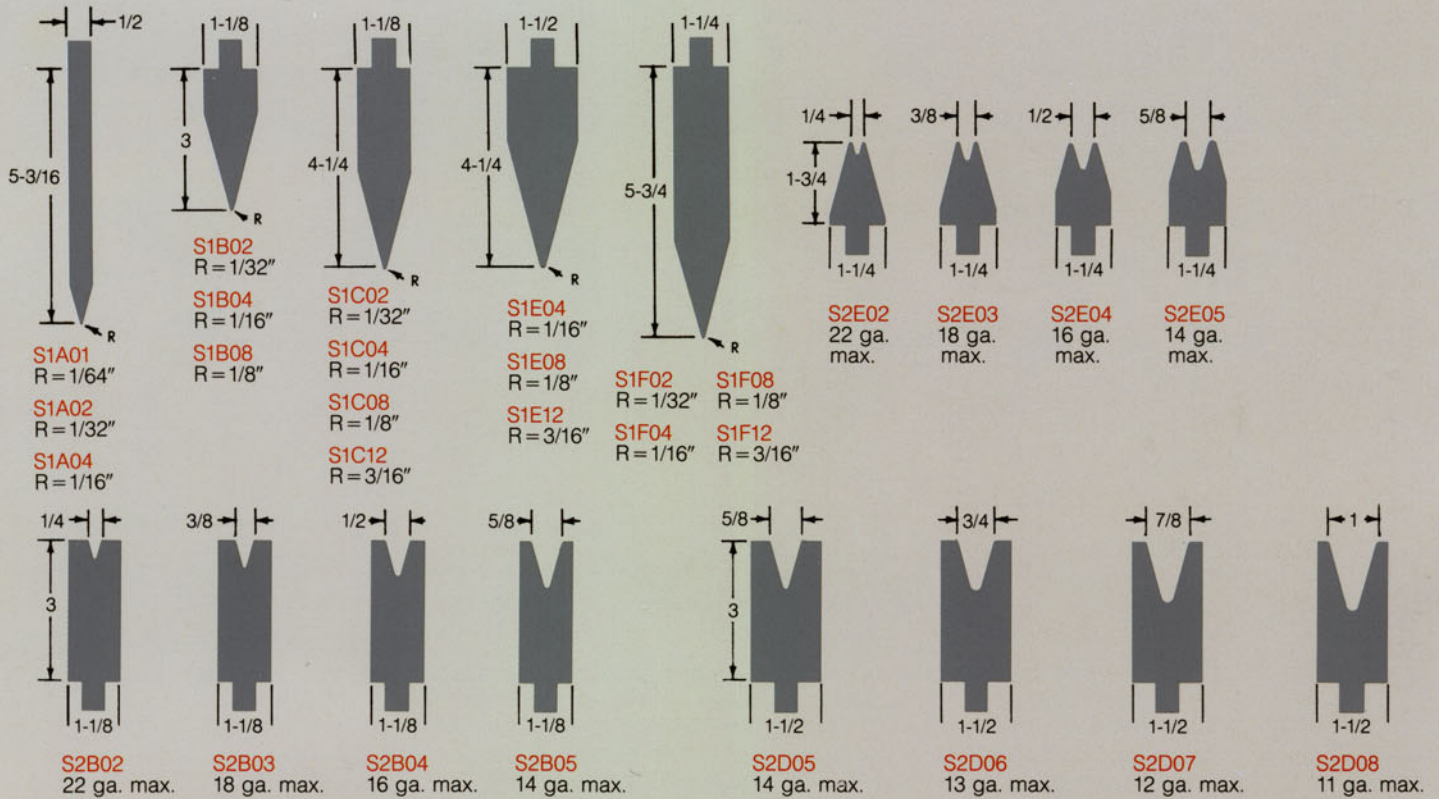

BOTTOMING DIES

All included angles **90°**

Bottoming dies are used for making very accurate bends with relatively sharp inside radii in comparatively light gauge material, such as 12 gauge and thinner. Included angle is 90 degree for both upper and lower dies.

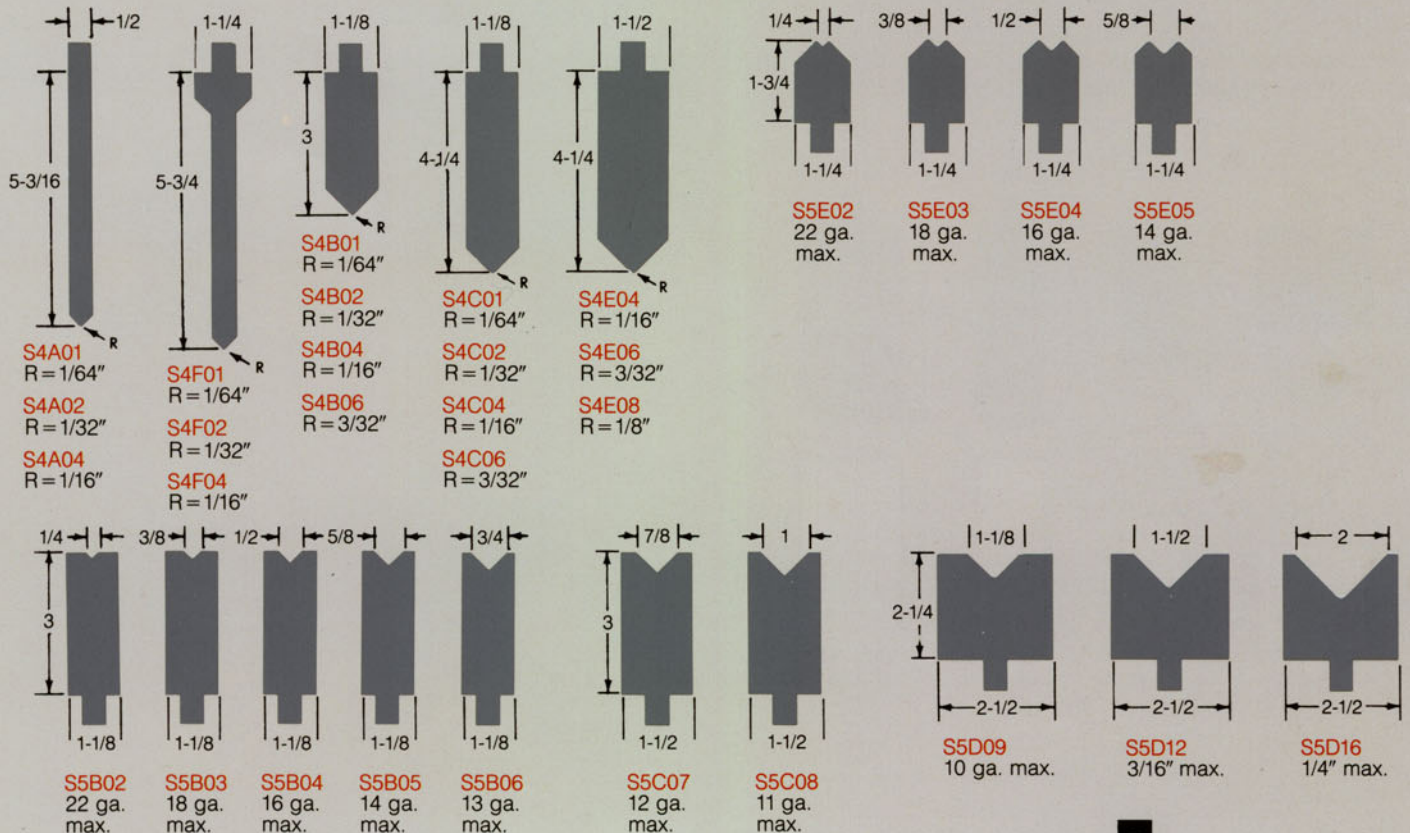

GOOSENECK DIES

Gooseneck dies are used for making channels or special shapes with which a straight sided die would interfere. Deeper "throat" beyond the die centerline increases width of return flange but reduces die capacity. Interference can be checked using a gooseneck die template which can be requested from CINCINNATI.

All included angles **85°**

Included angle **30°**

All included angles **90°**

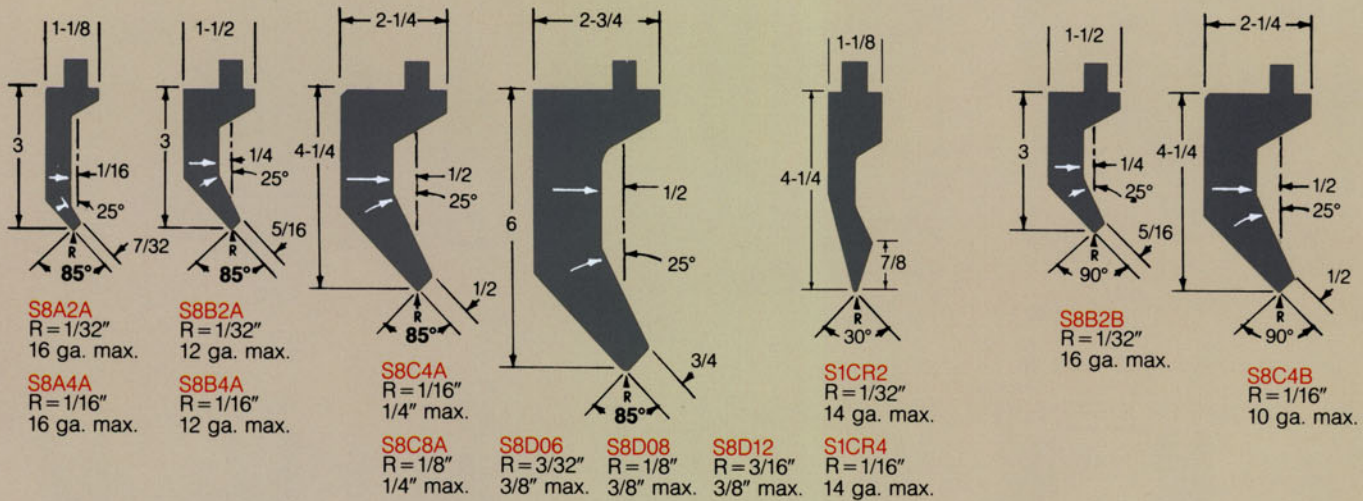

If parts are to be formed with "air bend" dies on a press brake with controls that use mathematical models (i.e. AUTOFORM®) to determine ram reversal positions, the dies must be cut to a 75 degree or less angle to compensate for all possible material springback. In some cases, 30 degree dies can be selected to obtain true air bending of 90 degree angles.

FLATTENING DIES

Flattening dies are used for "hemming" or flattening acute angle bends. Flattening dies and acute angle dies mounted side by side in a press brake can produce a hem with each press brake stroke.

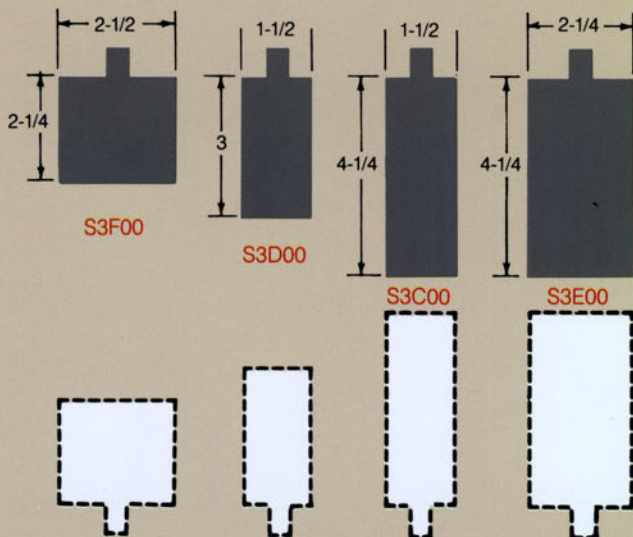

FOURWAY DIES

All vees **85°** unless otherwise specified

Fourway dies are useful for jobbing work where changes in die opening are frequently desired.

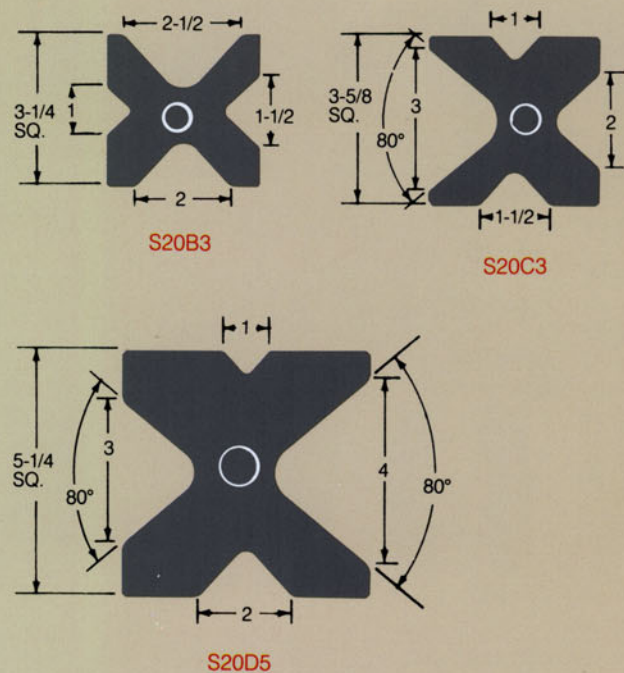

CINCINNATI

Also available is a wide selection of bar sizes, maintained in our inventory, which can be modified to your specific needs. Reference die set identification numbers shown when requesting pricing or delivery.

Modified Standard Dies



Off Angle

Special Nose



High Box Die



Adapter

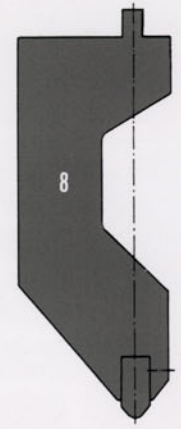

3 Way & 4 Way

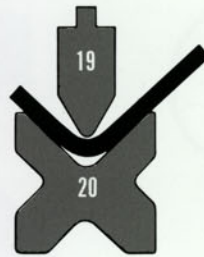

Additional Special Tooling

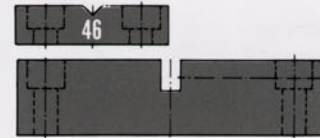

Adjustable Vee Dies

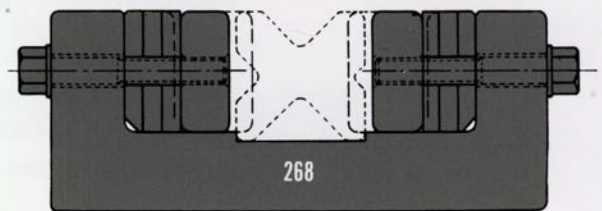

Offset



Offsets and Joggles

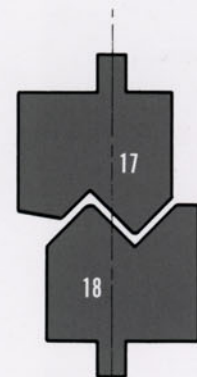
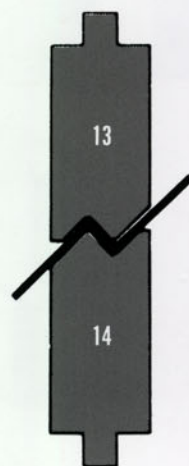
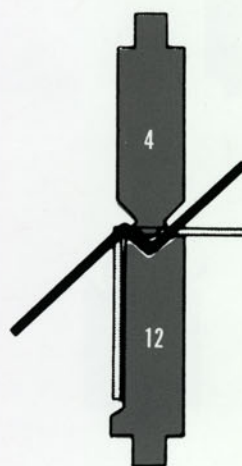

Beading and Curling

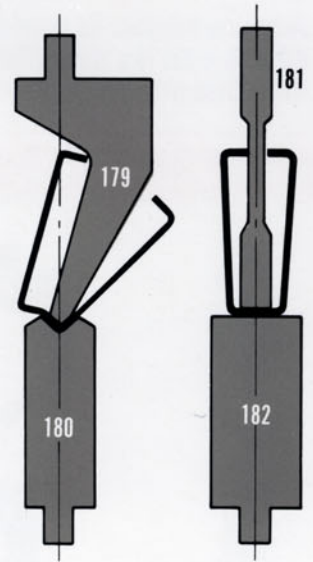
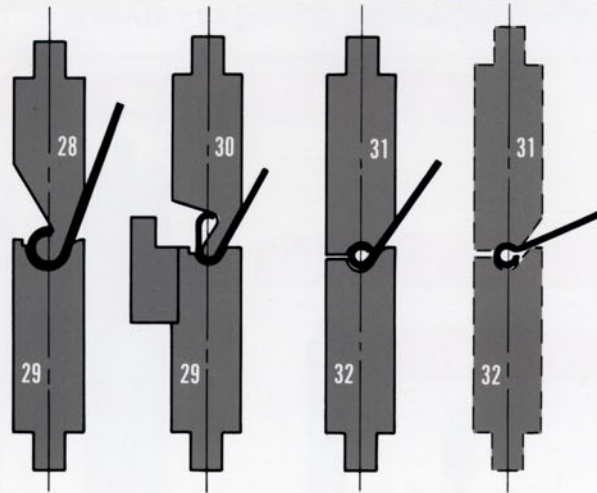

Round Tubes and Pipe

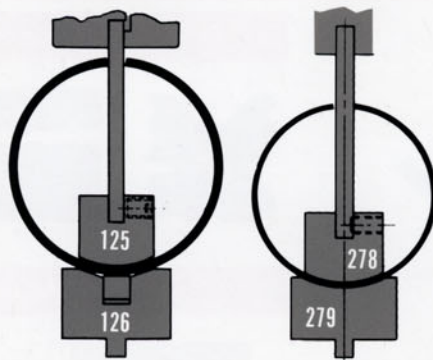

Radius Bends

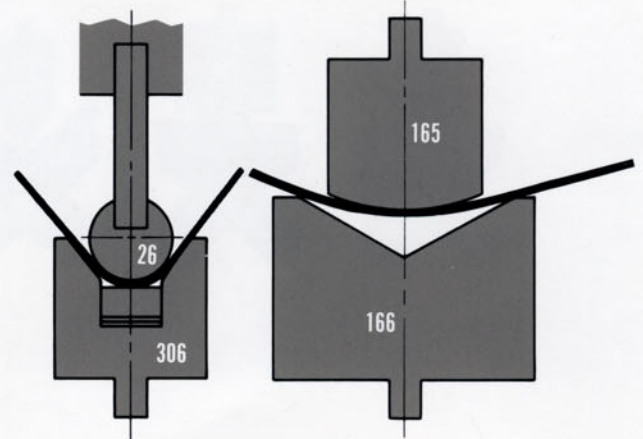

Tube Forming

1st Oper. 2nd Oper. 3rd Oper.

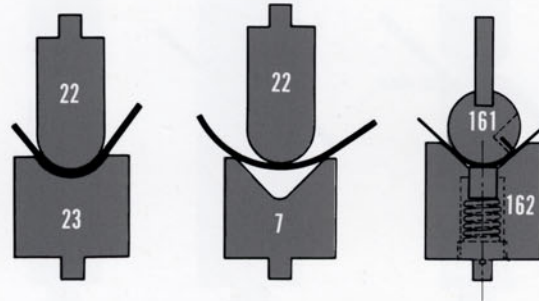
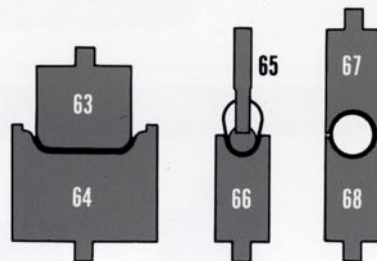

Tubular Edge Forms

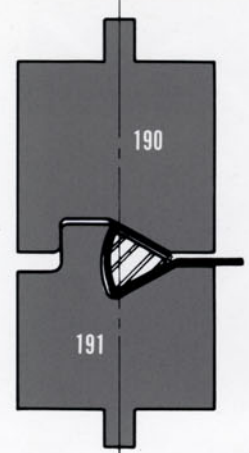

Ribs

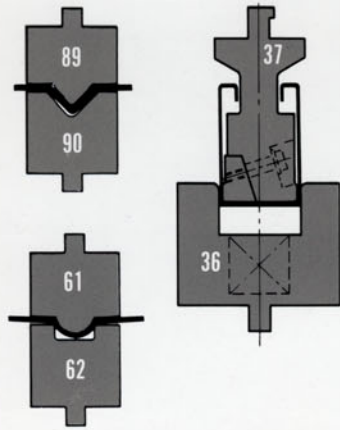

Channels

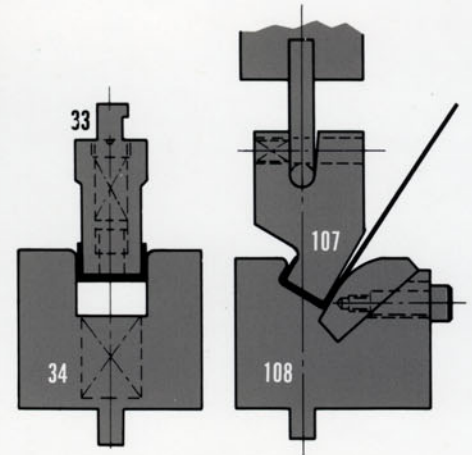

Hems and Seams



Standing Seam

1st Oper. 2nd Oper.

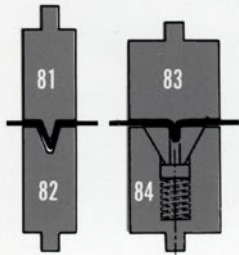

Lock Seams

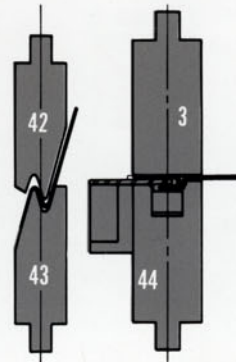

Hemming

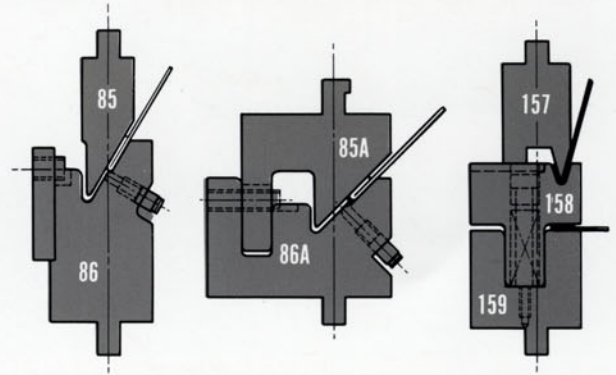

Other Applications



Wiping

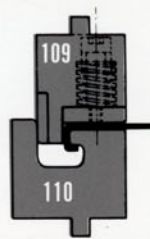

Stair Risers, Doorbucks

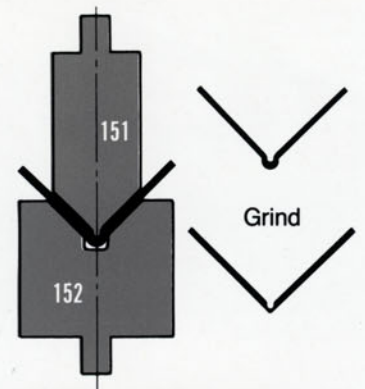

Truss Members and Corrugations

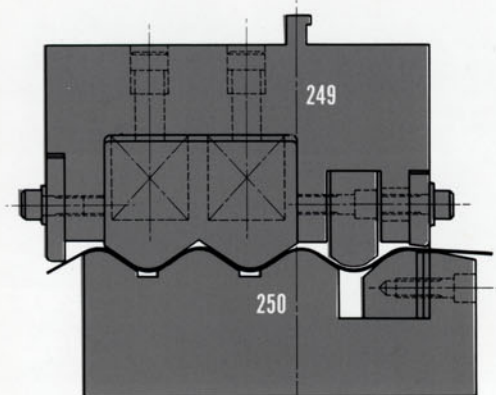

Double Deck

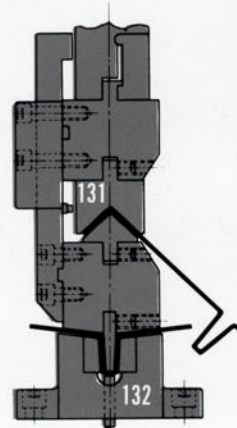

90° Flanges

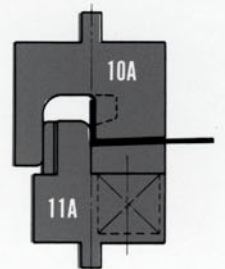

CINCINNATI

Stocked Press Brake Gaging

CINCINNATI's gaging facilitates locating proper bending sequence with convenient gaging setups to fit most applications. The gages have full horizontal and vertical adjustments. These gages are applicable to most Press Brakes and mount on the front or rear of the machine.

If any of these gages are to be used on a CINCINNATI Press Brake with Auto Crown®, special slide blocks are required to prevent interference between the vertical support bracket and the Auto Crown® plate.

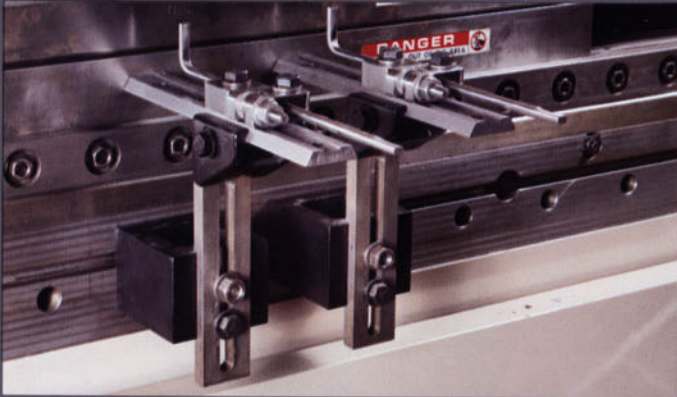

All gages can be set for forming wide or narrow sheets either upward or downward. They can also be used as an adjustable two-step gage. CINCINNATI Standard Gages are available with or without micrometer adjustment to the gage rod.

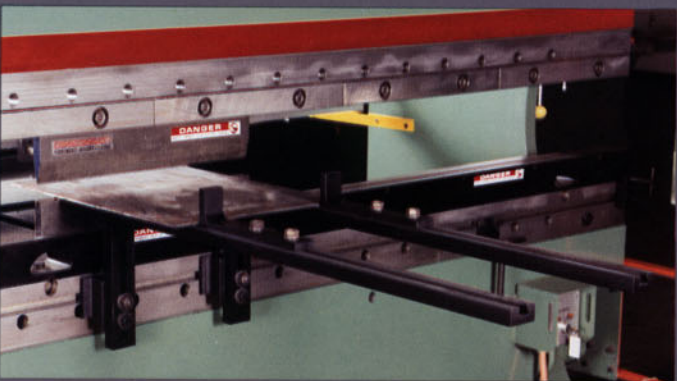

CINCINNATI Heavy Duty Gages with massive stops are particularly recommended for use in plate shops where very rugged construction is necessary.

The Heavy Duty Gage is also available with interchangeable gaging rods for use with light sheets.

KEEP SAFETY IN MIND

Each press brake operation must be evaluated to determine the appropriate point of operation safeguarding to use. Consult the American National Standards Institute (ANS B11.3 safety standard), National Safety Council and similar sources for safeguarding help. The press brake operator should consult his superior if his operation is not properly safeguarded. Safety manuals, safety guidelines for operator and service personnel and a book with press brake safeguarding suggestions are available from CINCINNATI. If you do not have them call or write for them now.

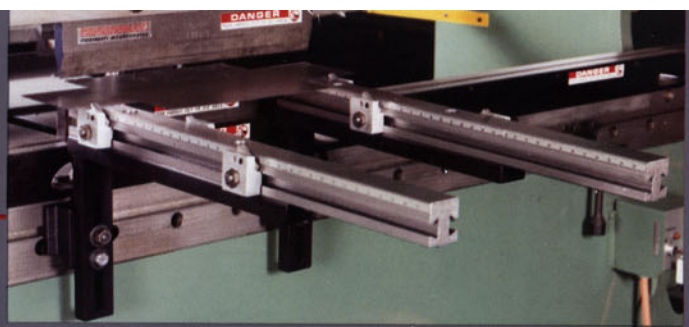

CINCINNATI Adjustable Flip Gages provide multiple gaging positions with complete flexibility in vertical and horizontal positioning. Disappearing gage assemblies with either $\frac{5}{16}$ " or $\frac{5}{8}$ " rise are located on either side of heavy duty gage bars. Scales graduated in sixteenths are mounted flush on each side of the heavy duty gage bars. Any number of stops may be used.

CINCINNATI Pin Gage assemblies mount on the same dovetail arms as used for CINCINNATI Adjustable Flip Gages. Operator can locate bend line directly and accurately from prepunched holes.

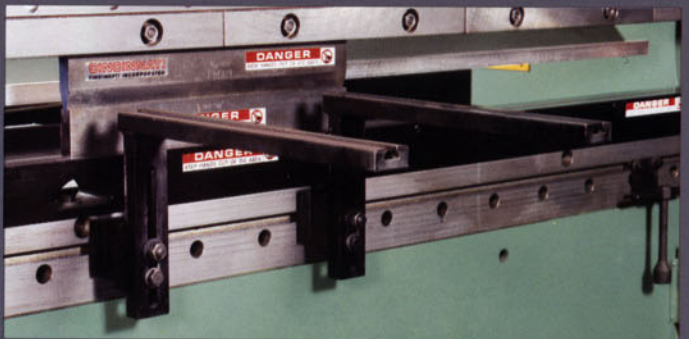

CINCINNATI Work Support Brackets permit increased efficiency in handling material at the front or rear of the press brake. Horizontal support can be 24 inches, 36 inches, or 48 inches depending on the application.

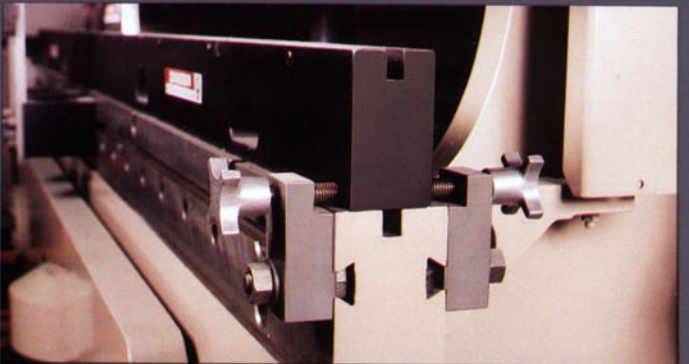

CINCINNATI Die Aligners enable filler blocks and keyless dies to be aligned on the press brake bed. These items are designed to fit a dovetail slot in the bed and are furnished in a set of six.

CINCINNATI

CINCINNATI INCORPORATED

(513) 367-7528

FAX: (513) 367-7552

Box 11111, Cincinnati, Ohio 45211