

PRATT

Henry Pratt Company

N-Stamp

Butterfly Valves



Valves for the 21st Century



A Tradition of Excellence

With the development of the first rubber seated butterfly valve more than 70 years ago, the Henry Pratt Company became a trusted name in the flow control industry, setting the standard for product quality and customer service. Today Pratt provides the following range of superior products to the water, wastewater and power generation industries.

BUTTERFLY VALVES: from 3" to 168"

RECTANGULAR VALVES: 3' x 3' to 12' x 12'

BALL VALVES —

RUBBER SEATED: from 4" to 60"

METAL SEATED: from 6" to 48"

PLUG VALVES: from 3" to 36"

VENTURI FLOW TUBES: from 1½" to 102"

DISMANTLING JOINTS: from 1½" to 216"

ENERGY DISSIPATING VALVES

A Commitment to Meeting The Customers' Needs

Henry Pratt valves represent a long-term commitment to both the customer and to a tradition of product excellence. This commitment is evident in the number of innovations we have brought to the industries we serve. In fact, the Henry Pratt Company was the first to introduce many of the flow control products in use today, including the first rubber seated butterfly valve, one of the first nuclear N-Stamp valves, and the bonded seat butterfly valve.

Innovative Products For Unique Applications

Though many of the standard valves we produce are used in water filtration and distribution applications, Pratt has built a reputation on the ability to develop specialized products that help customers to meet their individual operational challenges.

Creative Engineering for Fluid Systems

Pratt's ability to provide practical solutions to complex issues is demonstrated by the following case histories.

Valves Designed for Zebra Mussel Control

Pratt designed and manufactured a variety of large size circular and rectangular butterfly valves for use in recirculating hot water systems for zebra mussel control at several Midwestern fossil fuel power generating stations.

Earthquake Proof Valves

Pratt designed and manufactured hydraulically actuated valves for a water storage application so that the valves would automatically operate in the event of earthquakes. This led to the development of a valve that will withstand forces of up to 6g's.

Custom Actuation/ Isolation Valves

Pratt designed and manufactured valves that would isolate a working chamber in the event of a nuclear emergency during the decommissioning of armed nuclear warheads. The valves were able to close in a millisecond using specially designed Pratt electro-pneumatic actuators.

Valves Designed for Harsh Environments

Pratt designed and manufactured a 144" diameter butterfly valve for the emergency cooling system at a jet engine test facility. The valve was designed to supply water to help dissipate the tremendous heat generated by the engines during testing.

PRATT

Henry Pratt Company

Through experience, commitment and creative engineering, Pratt is uniquely suited to provide superior products for our customers' special needs. For more information, contact our corporate headquarters in Aurora, Illinois or your local Pratt sales representative listed on the inside back cover.



Henry Pratt Company

401 South Highland Avenue
Aurora, Illinois 60506-5563
<http://www.henrypratt.com>
phone: 630.844.4000
fax: 630.844.4160

TABLE OF CONTENTS

COMPANY BACKGROUND -	PAGE
A TRADITION OF EXCELLENCE	1
 QUALITY ASSURANCE -	
N-STAMP PROGRAM	2
 SCOPE OF LINE -	
SERIES 1100 NUCLEAR WATER SERVICE VALVE: DESIGN DETAILS	3-4
SERIES 1200 NUCLEAR AIR SERVICE VALVE: DESIGN DETAILS	5-6
SERIES 1400 NUCLEAR CORROSION RESISTANT VALVE: DESIGN DETAILS.....	7-8
 VALVE DIMENSIONS -	
SERIES 1100/1200 WELD BY WELD ENDS	9
SERIES 1100/1200 FLANGE BY WELD ENDS.....	9
SERIES 1100/1200 FLANGE BY FLANGE ENDS	10
SERIES 1400 FLANGE BY FLANGE ENDS.....	10
 ACTUATION -	
MANUAL ACTUATORS	11
ELECTRIC ACTUATORS	12
PNEUMATIC ACTUATORS.....	13
 SEISMIC AND OPERABILITY QUALIFICATION	14
 SUGGESTED SPECIFICATIONS -	
ASME CLASS 2 & 3 NUCLEAR SAFETY RELATED WATER SERVICE BUTTERFLY VALVES.....	15
ASME CLASS 2 & 3 NUCLEAR SAFETY RELATED AIR SERVICE BUTTERFLY VALVES	16
 OTHER PRATT PRODUCTS.	SEE BACK COVER

SERVING THE NUCLEAR POWER INDUSTRY FOR MORE THAN 40 YEARS

A Tradition of Excellence

Over 40 years ago, Pratt began providing butterfly valves to the nuclear power industry. In the infancy of the industry, Pratt was called upon to manufacture quick closing butterfly valves for containment isolation applications at nuclear power facilities across the United States and abroad. Ranging in size from 10 to 48 inches, the valves were designed to close in seconds using spring loaded actuators to isolate the containment structure and prevent the escape of radioactive materials.

In the years that followed, Pratt continued to design and manufacture valves, uniquely suited to the nuclear power industry. When the American Society of Mechanical Engineers (ASME) implemented their authorization program to ensure the quality of products provided to the industry, Pratt was one of the first valve manufacturers to obtain an N-Stamp and NPT-Stamp certification. Today, over 50% of the butterfly valves installed in nuclear power plants across the United States bear the Pratt name. Since 1972, the Henry Pratt Company has continuously maintained its N-Stamp and NPT-Stamp certification, having recently passed an ASME audit for the eighth time. Pratt was there when the first power plants were built and we are here today to continue our tradition of providing excellent products and service to your industry.

Superior Service.....Nationwide

Whether you require spare parts, replacement valves or just sound advice, Pratt is ready to respond. Our in-house Spare Parts Department has decades of experience servicing the requirements of engineers and plant personnel in the nuclear power industry. Pratt's skilled Field Service Technicians can travel to your plant to inspect, repair or replace product to support your outage and maintenance efforts. To further ensure that we meet your urgent plant needs, a Pratt Sales Representative office, staffed with knowledgeable personnel, is located near you and your facility. Whether the valve was supplied last year or 40 years ago, we can meet your spare parts or replacement requirements.

Replacement Valves to Meet Today's Requirements

Many of the original butterfly valve suppliers serving the nuclear power industry no longer exist or, if they are still in business, they no longer hold an N-Stamp. Pratt has the capability to replace those "extinct" valves with superior quality butterfly valves with the same face-to-face dimensions, weight and operating characteristics as the original valve, all under our N-Stamp program.



A Database for Your Plant

To ensure prompt and individualized service, a data base of Pratt products has been created for each nuclear power plant in the U.S. The database acts as a record of all Pratt valves shipped to each plant, containing such information as original customer purchase order number, valve serial number, date of shipment, the sizes and quantity of valves supplied and actuator type. This information helps us to swiftly respond to customer inquiries.

Our Promise to You

As we enter the 21st century, Pratt continues in its commitment to serve the nuclear power industry by providing superior quality valves for the life of your plant.

QUALITY ASSURANCE PROGRAM

N-Stamp Certification

Henry Pratt Company holds Certificates of Authorization from the ASME to manufacture valves bearing the N Symbol for Classes 1,2 and 3 Nuclear Valves and parts bearing the NPT Symbol for Classes 1,2 and 3 Nuclear Valve Parts. The company meets and exceeds all of the requirements for building nuclear valves, ranging in size from 3 to 144 inches, in strict accordance with Section III of the ASME Boiler and Pressure Vessel Code.

Pratt nuclear butterfly valves are typically used for containment purge isolation service, essential service water and safety-related cooling water systems in both BWR and PWR plants. Pratt valves utilize proven seating methods in valve structures especially designed for nuclear service and Code requirements.

Quality That Lasts For Years

Valves built under our N-Stamp and standard Quality Assurance Program consistently stand the test of time. Most of the Pratt butterfly valves originally furnished to nuclear power plants in the 1960s and 1970s are still in service today, having required little or no maintenance over the years.

Quality Assurance Program

Quality Assurance is one of the most significant factors in choosing a product for nuclear service. Henry Pratt Company's program to assure the quality of the products we produce is the result of decades of industry know-how and a commitment to serving our customers. Our Quality Assurance Program covers a myriad of operations from inception to implementation, in strict conformance to the criteria of NA 4000 and the ASME Boiler and Pressure Code, Section III, Division 1, Classes 1,2 and 3.

Nuclear Quality Assurance Documentation

Pratt provides the following standard documentation package with every valve furnished under our N-Stamp program. In addition to our standard documentation, a permanent file containing all drawings, Bills of Materials, process/test documentation, certifications and records required by the Code is maintained for each N-Stamp product furnished.

- A) ASME Data Report (NPV-1 Form)
- B) Certificate of Compliance to the Design Specifications
- C) Certificate of Compliance to the Seismic Requirements
- D) Assembly and Test Record
- E) Body Wall Thickness Record
- F) For body, disc and shaft:
 - 1. Certified Material Test Report (chemical and physical)
 - 2. Records of Non-Destructive Examination (when applicable)
 - 3. Receiving, In-Process and Final Inspection Reports
 - 4. Weld Repair and Fabrication Records (when applicable)
 - 5. Heat Treat Data (when applicable)
 - 6. Radiographs (when applicable)
- G) For other components such as bottom covers, bottom cover bolting and seat rings:
 - 1. Certificate of Compliance to Specified Material Specifications
 - 2. Inspection Reports

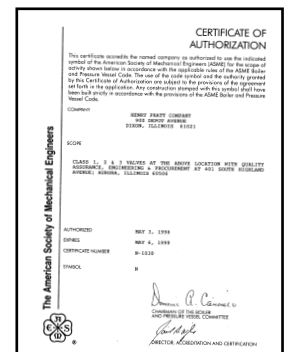
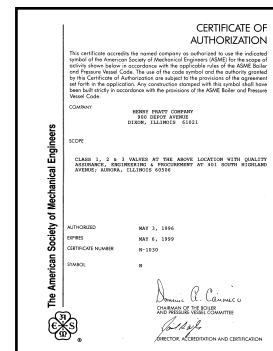

Henry Pratt Company Nuclear Butterfly Valves and Valve Parts,
Made with Pride in the U.S.A.,
bear the ASME N Symbol, certificate number N-1030 and
the ASME NPT Symbol, certificate number N-1031.

SCOPE OF LINE: PRATT SERIES 1100 NUCLEAR WATER VALVE

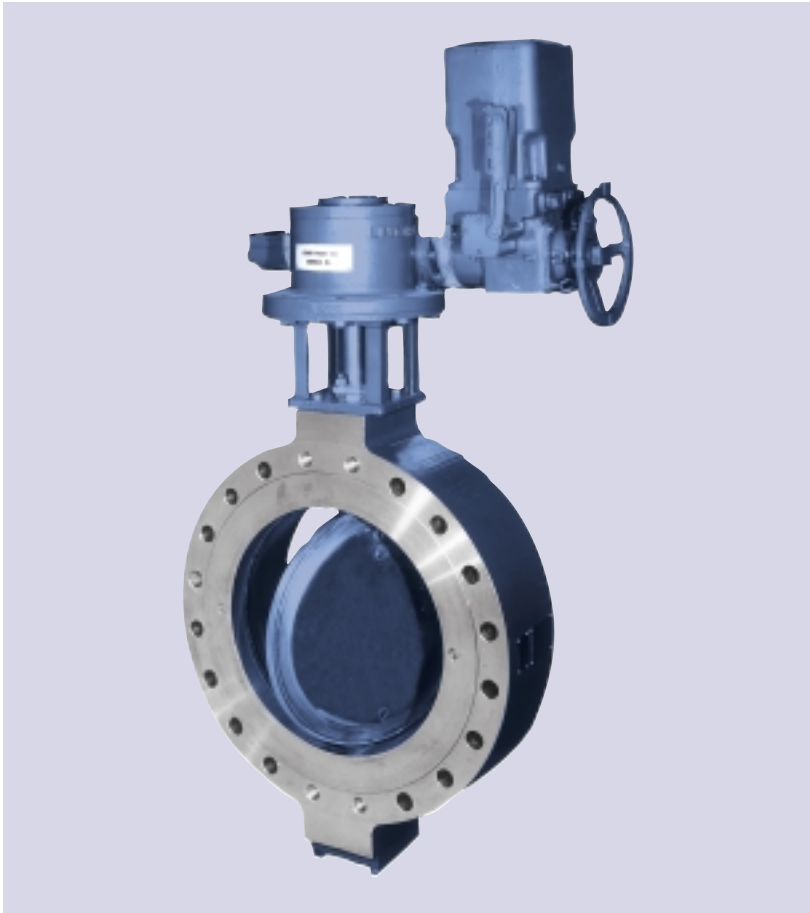

ASME CLASS 2 & 3 NUCLEAR SAFETY RELATED WATER SERVICE BUTTERFLY VALVES

Sizes:

6 inches through 36 inches standard.
Consult factory for larger sizes.

Body Styles:

Flange by Flange

Weld by Weld

Flange by Weld

Design Rating:

- Standard pressure class: ANSI 150#

- Maximum Shut Off Pressure for

Bubble Tight Service: 200 psig

- Maximum Normal Service

Temperature: 200^o F.

- Maximum Radiation Exposure: 1 x 10⁷ Rad.

- Seismic Rating:

Class 1 for active and non-active services. The upset, emergency or faulted conditions will be analyzed concurrently with 5g seismic load applied simultaneously along three major axes. The stress levels will be maintained within the Code allowables.

- Valve Operability Assurance:

Pratt will submit a program for providing valve operability assurance to meet the intent of NRC Reg. Guide 1.48 describing the valves to be tested, type of testing and test conditions.

FULL OPEN C_v VALUES: SERIES 1100 NUCLEAR VALVE

Valve Size	Flat Disc	Arch Disc
6	1160	--
8	2070	--
10	4010	--
12	5780	--
14	7870	--
16	10280	--
18	13000	--
20	16056	--
24	23120	--
30	44505	36954
36	53568	55998

A SEAT DESIGNED FOR LONG LIFE

The Pratt Series 1100 Nuclear Water Valve combines the reliability of no moving parts for seat adjustment with extraordinary ease of adjustment. The rubber seat is mechanically retained by cast epoxy. At manufacture, the valve disc is rotated to the closed position with the elastomer seal in position. Injection of liquid epoxy behind the elastomer forces it against the stainless steel seat surface with a uniform pressure around the complete circumference of the disc. Since the procedure automatically compensates for any differential in clearance between the disc and body, a tight seal is obtained with lower maximum elastomer stress levels and resultant longer life expectancy. Seat adjustment or replacement in the field, can be performed without removing the valve from the pipeline, using a disposable injection kit.

DESIGN DETAILS: PRATT SERIES 1100 NUCLEAR WATER VALVE

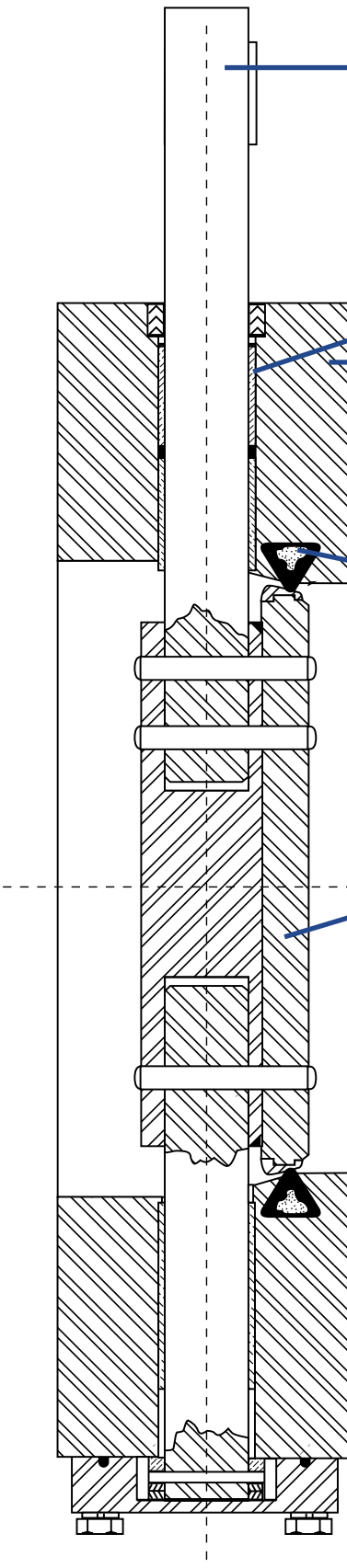

Shaft:

Two piece design, each stub shaft is inserted in its valve disc hub a minimum distance of $1\frac{1}{2}$ times the shaft diameter. The diameter is not reduced at the bearing.

Shaft material: SA-564, Type 630 (Cond. 1150). On 6 and 8 inch valves, a one-piece shaft is used.

Bearings:

Corrosion resistant sleeve-type, installed in the valve body trunnions.

Bearing material: Bronze.

Body:

Flanged or prepared for welding to the adjacent pipe. Weld end preparation in accordance with customer specification. Flanges for valves up to 24 inches conform to ANSI B16.5. Larger valves built in compliance with Code Case 1678, 1702 or 1744 as applicable. Valve bodies with drilled and tapped holes are suitable for Class 2B alloy bolt thread series. Flange bolt holes are not drilled and tapped through entire body thickness. All valve sizes are suitable for dead-end service.

Body material: SA-216, Gr. WCB or SA-516, Gr. 70.

Seat:

Seat is mechanically retained in the body without using threaded fasteners. It is field adjustable and replaceable except in rubber lined bodies. This design has many years of qualifying experience in water applications and has passed cycle life testing in accordance with AWWA C504, paragraph 12.4.2. An Affidavit of Compliance with this testing is furnished with each valve.

Seat material: Ethylene Propylene Terepolymer (EPT) elastomer with cast epoxy retainer.

Disc:

Fabricated or cast construction with no external ribs perpendicular to flow. Welded to the carbon steel disc is a stainless steel seating edge covering the full width of the seating surface. Disc rotates 90° from fully open to fully closed and is mechanically locked with the valve shaft.

Disc material for valves 10 inches and larger: SA-216, Gr. WCB or SA-516, Gr. 70. Stainless steel seating edge material for valves 10 inches and larger.

Disc material for valve sizes 6 and 8 inches: SA-479, Type 304 stainless steel.

Trim:

Packing and o-rings are constructed of Ethylene Propylene Terepolymer (EPT).

Materials for Special Applications:

For salt, brackish or borated water service or for any other corrosive fluid service, the valve body can be lined with $\frac{3}{16}$ " rubber extending over the valve flange face. A solid stainless steel (SA-351, CF8M) disc and Monel shafts are available. Other materials may also be furnished as allowed by the Code.

Note: on 6 and 8 inch valves, only one disc-shaft pin is used.

SCOPE OF LINE: PRATT SERIES 1200 NUCLEAR AIR VALVE

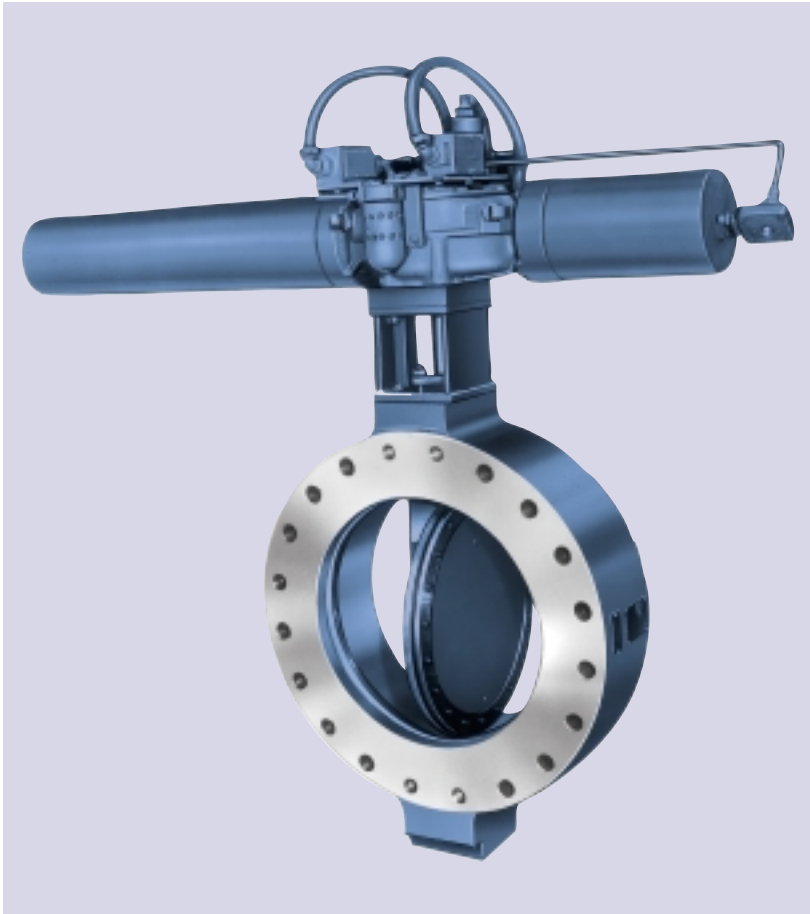

ASME CLASS 2 & 3 NUCLEAR SAFETY RELATED AIR SERVICE BUTTERFLY VALVES

Sizes:

6 inches through 48 inches standard.
Consult factory for larger sizes.

Body Styles:

Flange by Flange

Weld by Weld

Flange by Weld

Design Rating:

- **Standard pressure class:**

ANSI 150# Class valves up to 24 inches

- **Maximum Normal Service Temperature:** 300° F.

- **Maximum Faulted Condition Temperature:** 350° F.

- **Maximum Radiation Exposure:** 1 x 10⁸ Rad.

- **Seismic Rating:**

Class 1 for active and non-active services. The upset, emergency or faulted conditions will be analyzed concurrently with 5g seismic load applied simultaneously along three major axes. The stress levels will be maintained within the Code allowables.

- **Valve Operability Assurance:**

Pratt will submit a program for providing valve operability assurance to meet the intent of NRC Reg. Guide 1.48 describing the valves to be tested, type of testing and test conditions.

FULL OPEN C_v VALUES: SERIES 1200 NUCLEAR VALVE

Valve Size	Flat Disc	Arch Disc
6	1160	--
8	2070	--
10	4010	--
12	5780	--
14	7870	--
16	10280	--
18	13000	--
20	16056	--
24	23120	--
30	44505	36954
36	53568	55998
42	77166	80199
48	100800	104760

UNIQUELY SUITED TO MEET YOUR NEEDS

The Pratt Series 1200 Nuclear Air Valve is specifically designed for use in air or gas service in the containment annulus and drywell areas. Its elastomer seat is suitable for high radiation and temperature, and seals reliably at both low and high pressures. If at a periodic inspection the seat is found to require maintenance, it can easily be adjusted or replaced in the field without removing the valve from the line.

With the valve seat mechanically retained on the disc, the elastomer is located in a position that protects it from heat developed at the weld end during installation. The mechanical retention of the seat on the disc eliminates the problems associated with screws in the valve body, permitting minimum code wall requirements to be met without excessive wall thickness or excess valve weight.

DESIGN DETAILS: PRATT SERIES 1200 NUCLEAR AIR VALVE

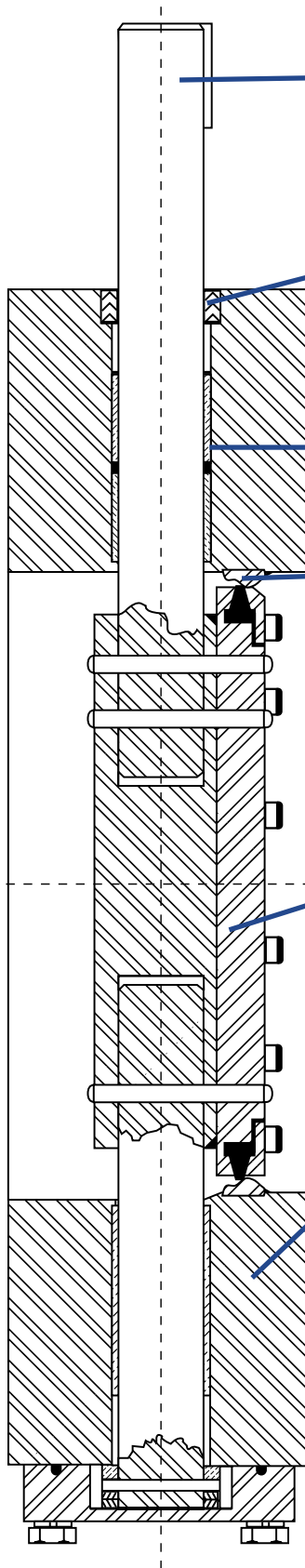

Shaft:

Two piece design, each stub shaft is inserted in its valve disc hub a minimum distance of $1\frac{1}{2}$ times the shaft diameter. The diameter is not reduced at the bearing.

Shaft material: SA-564, Type 630 (Cond. 1150).

Shaft Seals:

Self-adjusting EPT chevron type with a minimum of three rings per set. Valves normally containing radioactive fluid can be supplied with two independent sets of packing separated by a lantern ring and a leak-off connection, tapped $\frac{1}{2}$ inch NPT and plugged. Shaft seals are replaceable without disturbing any part of the valve or valve/actuator assembly.

Seal material: Ethylene Propylene Terepolymer (EPT)

Bearings:

Corrosion resistant sleeve-type, installed in the valve body trunnions.

Bearing material: Bronze ASTM B-438, Gr. 1, Type 2.

Seat:

Seat is mechanically retained on the disc; adjustable and replaceable with access from the flanged end of the valve. Suitable for concurrent specified conditions of pressure, temperature and radiation

Seat material: Ethylene Propylene Terepolymer (EPT).

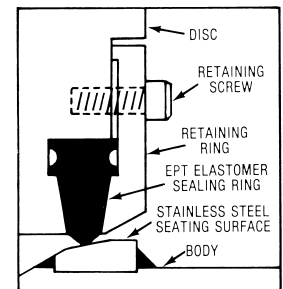

Disc:

Fabricated or cast construction with no external ribs perpendicular to flow. Disc rotates 90° from fully open to fully closed and is mechanically locked with the valve shaft.

Disc material: SA-516, Gr. 70. Seating surface which contacts the rubber seat is SA-479, Type 304 welded to the valve body per Code Case 1516.

Body:

Flanged or prepared for welding to the adjacent pipe. Weld end preparation provided in accordance with customer specification. Flanges for valves up to 24 inches conform to ANSI B16.5. Larger valves built in compliance with Code Case 1678, 1702 or 1744 as applicable. Valve bodies with drilled and tapped holes are suitable for Class 2B alloy bolt thread series. Flange bolt holes are not drilled and tapped through entire body thickness. All valve sizes are suitable for dead-end service.

Body material: SA-516, Gr. 70.

SCOPE OF LINE: PRATT SERIES 1400 NUCLEAR WATER VALVE



ASME CLASS 2 & 3 NUCLEAR SAFETY RELATED WATER AND AIR SERVICE BUTTERFLY VALVES

Sizes:

3 inches through 24 inches for water service.

Body Style: Lug Wafer, Wafer

Design Rating:

- Standard pressure class:

ANSI 150# Class valves up to 24 inches

- Maximum Shut Off Pressure for

Bubble Tight Service: 200 psig

- Maximum Normal Service Temperature: 300° F.

- Maximum Faulted Condition Temperature: 350° F.

- Maximum Radiation Exposure: 1 x 10⁸ Rad.

- Seismic Rating:

Class 1 for active and non-active services. The upset, emergency or faulted conditions will be analyzed concurrently with 5g seismic load applied simultaneously along three major axes. The stress levels will be maintained within the Code allowables.

- Valve Operability Assurance:

Pratt will submit a program for providing the valve operability assurance requirement to meet the intent of NRC Reg. Guide 1.48 with the proposal describing the valves to be tested, type of testing and test conditions.

FULL OPEN C_v VALUES: SERIES 1400 NUCLEAR VALVE

Valve Size	C _v Value
3	323
4	575
6	1293
8	2300
10	4460
12	6423
14	8742
16	11418
18	14451
20	17840
24	25690

RELIABLE UNDER THE HARSHEST OF CONDITIONS

The Pratt Series 1400 Corrosion Resistant Nuclear Valve is specifically designed to withstand corrosivity and high temperatures, making it suitable for salt, brackish and borated water service as well as other corrosive fluids. The permanently bonded valve seat also acts as a flange seal and shaft seal, isolating the valve body from corrosive fluids without the use of separate linings or coatings.

The Series 1400 valve is in complete conformity with AWWA C504 standards. The reliable, bubble-tight closure provided by the Series 1400 Nuclear Butterfly Valve seat also complies with AWWA cycle life test requirements for butterfly valves. The bonding process assures that ballooning of the seat (which could lock the disc in place) or seat blow-out are not possible.

DESIGN DETAILS: PRATT SERIES 1400 NUCLEAR WATER VALVE

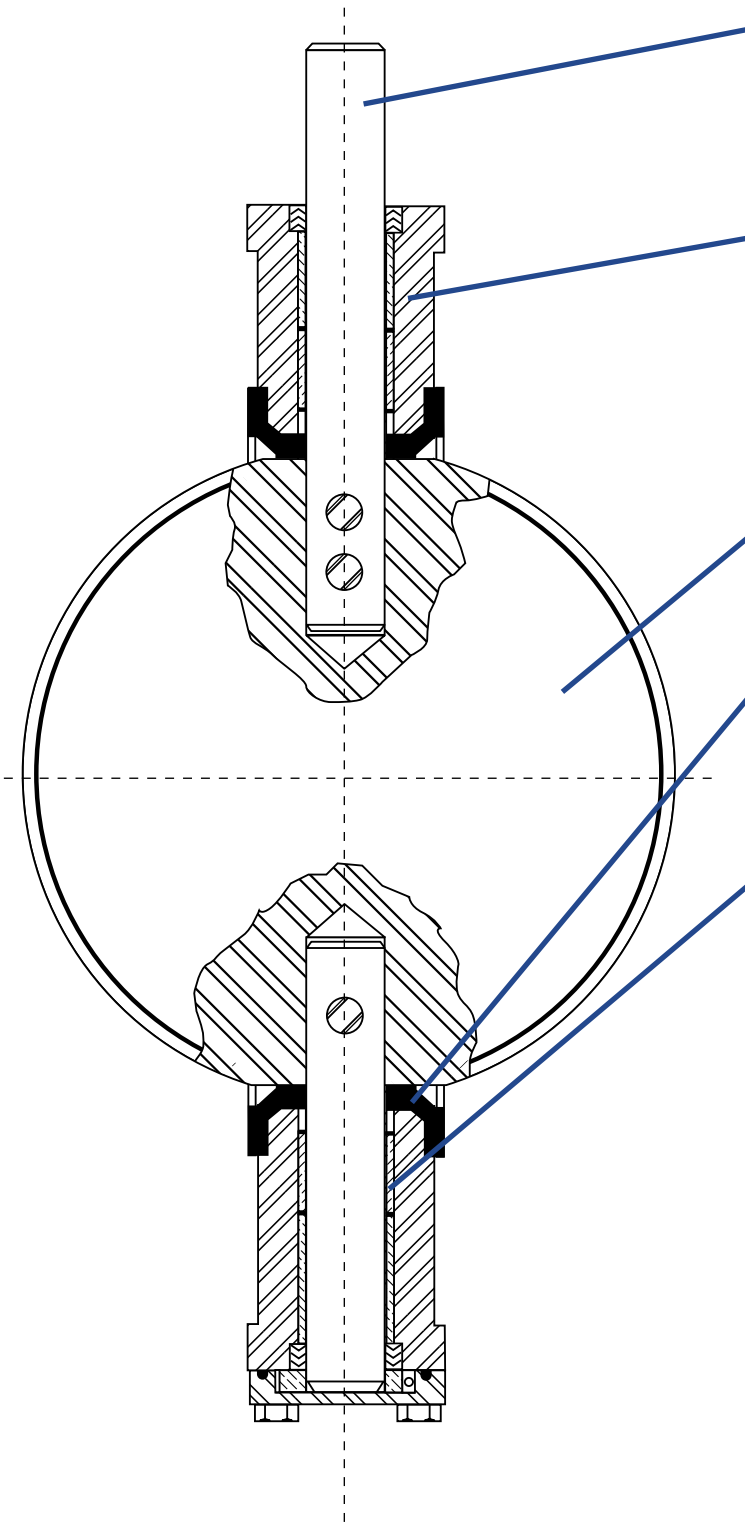

Shaft:

Two piece design, each stub shaft is inserted in its valve disc hub a minimum distance of 1 and one-half times the shaft diameter. The diameter is not reduced at the bearing or at the adaption to the actuator.

Shaft Material: SA-564, Type 630 (Cond. 1150).

Body:

Lug wafer or wafer with one-piece bonded elastomer flange gasket, lining and valve seat. Flanges for valves up to 24 inches conform to ANSI B16.5. Drilled and tapped holes are suitable for Class 2B alloy bolt thread series. Flange bolt holes are not drilled and tapped through entire body thickness. All valve sizes are suitable for dead-end service.

Body Material: SA-516, Grade 70.

Elastomers: Ethylene Propylene Terepolymer (EPT).

Disc:

Cast stainless steel construction with smooth lens-shaped configuration. Disc rotates 90° from fully open to fully closed and is mechanically locked with the valve shaft.

Material: SA-351, Type CF8M.

Seat:

Seat is constructed of Ethylene Propylene Terepolymer (EPT) elastomer permanently bonded to the body. It is designed to meet AWWA Standard C504 for cycle life. Suitable for concurrent specified conditions of pressure, temperature and radiation.

Bearings:

Corrosion resistant sleeve-type, installed in the valve body trunnions.

Material: Bronze ASTM B-438, Grade 1, Type 2.

Trim:

Packing and o-rings are constructed of Ethylene Propylene Terepolymer.

THE TESTED BOND

To assure a thoroughly reliable valve seat, the Pratt rubber seat bond is tested by ASTM Test No. D-429, Method B. This test, one of the most stringent means of measuring bond effectiveness, consists of a minimum 75-pound pull on a 1" sharp line at 90° to the sample. Repeated testing confirms the integrity of the rubber seat bond at over 100 pounds pull. When pushed to failure, the rubber normally ruptures rather than separating from its metal base.

VALVE DIMENSIONS: SERIES 1100/1200 NUCLEAR VALVES

1100/1200 Weld x Weld

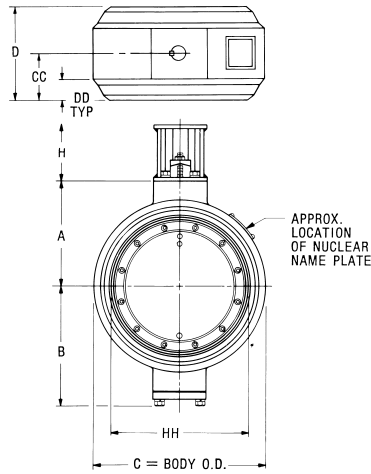

Nom. Valve Size	1100/1200 Weld x Weld Dimensions									
	A	B	C	D	H	AA	BB	CC	DD	HH
6	6½	8	9¼	8	7	6⅙	7⅙	4½	½	4⅙
8	7¾	9¼	11	8	7	8	½	4¼	1½	6⅙
10	9	10½	13	8	7	10	9⅙	4¼	1½	9⅙
12	10½	12⅙	15	10½	7	11⅙	5⅙	5½	1½	11⅙
14	11⅞	13⅙	16¼	10½	7	13⅞	2½	5½	1½	12⅙
16	13½	15⅙	18½	10½	7	15	¾	5¾	1½	14⅙
18	14¾	16⅙	20½	11½	7	16⅝	27/32	6	1¾	16⅙
20	16	17⅙	22½	11½	7	18⅙	29/32	6	1¾	17⅙
24	18⅞	20⅙	27½	11½	7	22⅝	1⅙	6¼	1¾	21¾

1100/1200 Flange x Weld

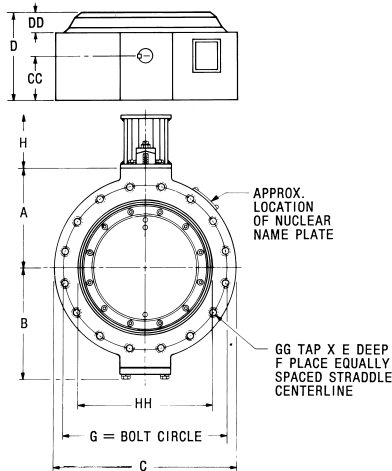

Typical Weld-End Preparation:

Pratt weld-end valves are suitable for either OD or ID pipe. The detailed drawings below are typical end preparations for either weld-end by weld-end or weld-end by flange end valve bodies. Additional dimensional data is contained in the tables provided.

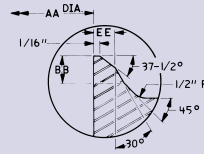

All dimensions shown in inches.

Nom. Valve Size	1100/1200 Flange x Weld Dimensions														
	A	B	C	D	E	F	G	H	AA	BB	CC	DD	EE	GG	HH
6	6½	8	11	6	1⅙	8	9½	7	6⅙	7⅙	2½	1½	9/32	¾"-10	5⅙
8	7¾	9¼	13½	6	1⅙	8	11¾	7	8	½	2½	1½	5/16	¾"-10	7¼
10	9	10½	16	6	1⅙	12	14¼	7	10	9⅙	2½	1½	3/8	7/8"-9	9¼
12	10½	12⅙	19	8	1⅙	12	17	7	11⅙	5⅙	3	1½	13/32	7/8"-9	11⅙
14	11⅞	13⅙	21	8	1½	12	18¾	7	13⅞	2½	3	1½	7/16	1"-8	12
16	13½	15⅙	23½	8	1½	16	21¼	7	15	¾	3	1½	½	1"-8	14
18	14¾	16⅙	25	8	1⅙	16	22¾	7	16⅝	27/32	3	1¾	9/16	1⅙"-8	15⅙
20	16	17⅙	27½	10½	1⅙	20	25	7	18⅙	29/32	4	1¾	19/32	1⅙"-8	17⅙
24	18⅞	20⅙	32	10½	1⅙	20	29½	7	18⅝	1⅙	4	1¾	1⅙	1⅙"-8	21¾

VALVE DIMENSIONS: SERIES 1100/1200/1400 NUCLEAR VALVES

1100/1200 Flange x Flange

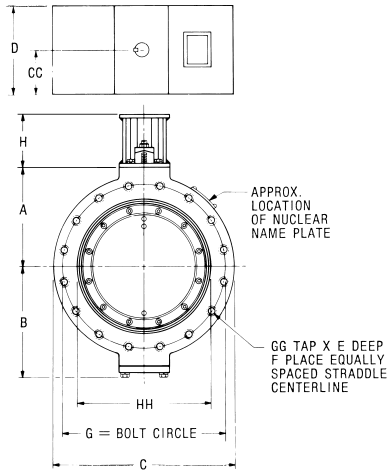

All dimensions shown in inches.

Nom. Valve Size	1100/1200 Flange x Flange Dimensions									
	A	B	C	D	E	F	G	H	GG	HH
6	6½	8	11	5	13/16	8	9½	7	¾"-10	415/16
8	7¾	9¼	13½	5	13/16	8	11¾	7	¾"-10	615/16
10	9	10½	16	5	15/16	12	14¼	7	7/8"-9	93/16
12	10½	121/16	19	6	15/16	12	17	7	7/8"-9	111/8
14	117/8	121/16	21	6	1½	12	18¾	7	1"-8	125/8
16	13½	151/16	23½	6	1½	16	21¼	7	1"-8	143/16
18	143/8	161/16	25	6	111/16	16	22¾	7	11/8"-8	161/16
20	16	1711/16	27½	8	111/16	20	25	7	11/8"-8	1715/16
24	187/8	209/16	32	8	113/16	20	29½	7	1¼"-8	213/4
30	251/32	303/8	383/8	12	113/16	20	36	10	1¼"-8	29
36	293/16	36¼	46	12	23/16	24	42¾	10	1½"-8	35

1100/1200/1400 Dimensional Data

- D dimension is + 1/16" for 6 - 10" valves; + 1/8" for 12" and larger valves. 30 and 36 inch dimensions apply only to Series 1100 and 1200.
- Pratt is approved as a nuclear valve source for sizes up to 144" and pressures to 300 psig.
- Dimensions are for reference only. Request certified general arrangement drawings for envelope dimensions of a specific valve/actuator assembly. See pages 11-13 for actuator data.

1400 Flange x Flange

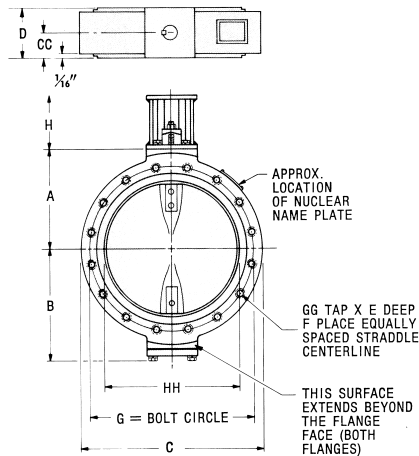

Nom. Valve Size	1400 Flange x Flange Dimensions										
	A	B	C	D	E	F	G	H	CC	GG	HH
3	5	6¾	6	21/16	15/16	4	6	7	1/32	5/8"-11	31/32
4	511/16	71/16	9	25/16	1	8	7½	7	15/32	¾"-11	4
6	621/32	813/32	11	215/16	13/16	8	9½	7	115/32	¾"-10	6
8	731/32	923/32	13½	31/16	13/16	8	11¾	7	117/32	¾"-10	8
10	95/8	113/8	16	33/16	15/16	12	14¼	7	119/32	7/8"-9	10
12	1115/32	137/32	19	37/16	15/16	12	17	7	123/32	7/8"-9	121/32
14	121/8	137/8	21	311/16	15/16	12	18¾	7	127/32	1"-8	133/32
16	135/8	153/8	23½	43/16	1½	16	21¼	7	23/32	1"-8	15¼
18	151/8	17	25	411/16	13/16	16	22¾	7	211/32	11/8"-8	175/16
20	171/8	19	27½	53/16	13/16	20	25	7	219/32	11/8"-8	195/16
24	1915/16	2113/16	32	63/16	13/8	20	29½	7	33/32	11/8"-8	23

MANUAL ACTUATION FOR PRATT NUCLEAR BUTTERFLY VALVES

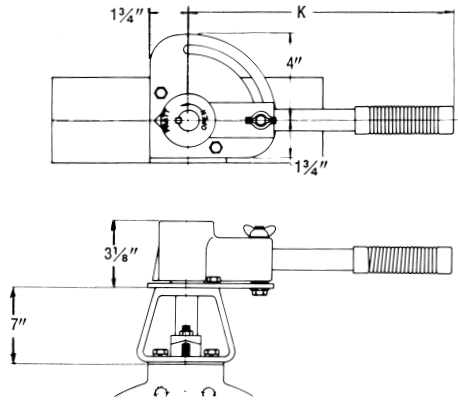

DIMENSIONS

All dimensions shown in inches.

PRATT HAND LEVER TYPE MANUAL ACTUATOR

Pratt's extra heavy steel hand lever, provided with a comfortable, non-metallic hand grip, is available for valve sizes up to 10 inches. For throttling, the lever is moved to any desired position and locked with a wing nut to resist movement from vibration or chattering. Standard lever lengths are 12 inches for valves through 6 inches in size and 18 inches for 8 and 10 inch valves.

Hand Lever Dimensions

Nominal Valve Size	K
3,4,6	12 $\frac{3}{4}$
8	18 $\frac{3}{4}$
10	18 $\frac{3}{4}$

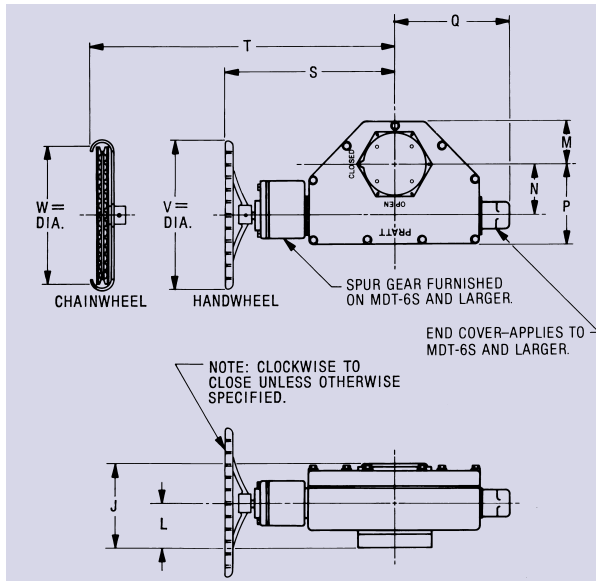

PRATT TRAVELING NUT TYPE MANUAL ACTUATOR

Pratt's MDT Manual valve actuators are of the traveling nut type and designed to produce the specified torque with a maximum pull of 80 pounds on the handwheel. Stop-limiting devices are provided and are capable of withstanding 350 foot pounds of input torque at full open or closed positions without damage to the valve or actuator.

Unlike a worm gear actuator, the Pratt MDT manual actuator is self-locking without a unidirectional sustained force from the valve. It can be relied upon to maintain exact valve position under conditions of fluctuating, turbulent and intermittent flow as well as severe valve and actuator accelerations. A Pratt nuclear butterfly valve equipped with an MDT actuator offers single source responsibility for valve and actuator.

MDT Size	Dimensions									
	J	L	M	N	P	Q	S	T	V	W
MDT-2S	4 $\frac{5}{8}$	2	2 $\frac{1}{2}$	2	4 $\frac{1}{2}$	4 $\frac{1}{8}$	8 $\frac{1}{4}$	7 $\frac{1}{2}$	8	9 $\frac{1}{8}$
MDT-3S	7 $\frac{1}{4}$	4 $\frac{1}{16}$	3 $\frac{1}{4}$	3 $\frac{3}{8}$	5 $\frac{1}{8}$	5 $\frac{1}{16}$	10 $\frac{1}{2}$	10	12	9 $\frac{1}{8}$
MDT-4S	8	4 $\frac{1}{2}$	3 $\frac{3}{8}$	4	7 $\frac{1}{16}$	6 $\frac{1}{4}$	11 $\frac{1}{2}$	11	12	9 $\frac{1}{8}$
MDT-5S	10 $\frac{1}{4}$	6 $\frac{1}{8}$	5 $\frac{1}{8}$	7	10 $\frac{1}{8}$	16	20	20 $\frac{1}{4}$	24	22 $\frac{1}{4}$
MDT-6S	12 $\frac{1}{2}$	7 $\frac{1}{8}$	7	8 $\frac{1}{4}$	12 $\frac{1}{8}$	18 $\frac{1}{8}$	26 $\frac{1}{4}$	25 $\frac{1}{8}$	24	22 $\frac{1}{4}$

ELECTRIC ACTUATION FOR PRATT NUCLEAR BUTTERFLY VALVES

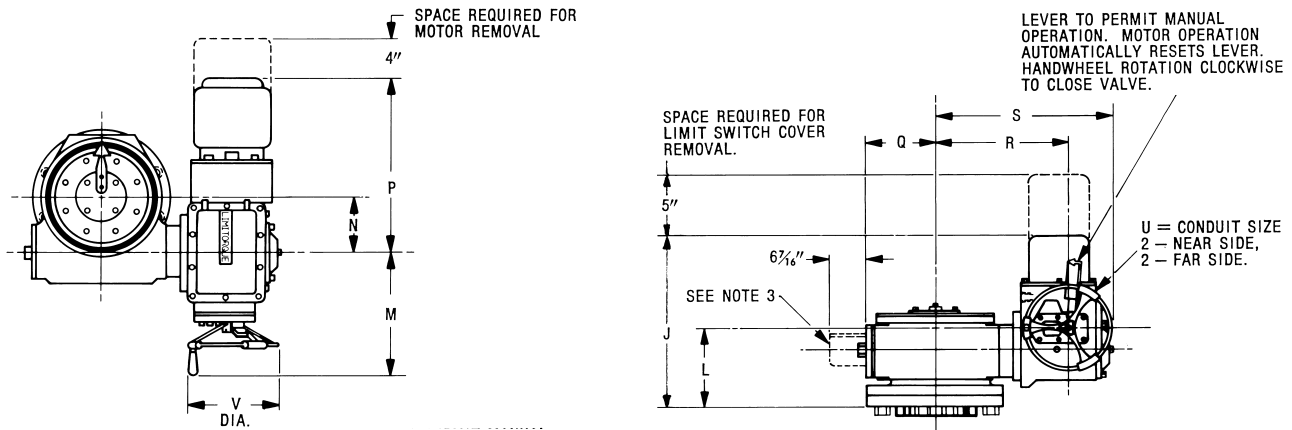

Electric Actuator Dimensional Data

Pratt furnishes electric motor actuators with a wide variety of motor/reduce combinations and almost any desired operating speed. Every actuator has a high torque motor specifically designed for valve control service, limit switches, local position indicators. Remote position indicators are also available. Valves are provided with a manual override in the event of power failure. Should power failure occur, the valve position can be changed by positioning the clutch lever and using the handwheel. Electric actuation overrides manual operation. Standard housing is weather proof. Explosion proof and submersible housings are also available.

Gear Actuator	Electric Motor	Dimensions									
		J	L	M	N	P	Q	R	S	U	V
WG-0	EM-1	17 ³ / ₁₆	3 ³ / ₁₆	13 ³ / ₈	2 ¹ / ₂	19 ³ / ₄	9 ¹⁵ / ₁₆	17 ⁷ / ₁₆	23 ³ / ₁₆	1 ¹ / ₂	12
WG-1	EM-1	18 ¹ / ₄	4 ⁵ / ₈	13 ³ / ₈	3 ¹ / ₂	17	11 ⁷ / ₈	17 ³ / ₈	23 ³ / ₈	1 ¹ / ₂	12
WG-2	EM-1	20 ¹ / ₄	4 ³ / ₄	13 ³ / ₈	4 ¹ / ₄	17	12 ⁵ / ₈	17 ³ / ₈	23 ³ / ₈	1 ¹ / ₂	12
WG-2	EM-2	20 ⁵ / ₈	7 ³ / ₈	17 ¹ / ₈	4 ¹ / ₄	23	12 ⁵ / ₈	14 ³ / ₄	20 ¹ / ₄	1 ¹ / ₂	12
WG-2	EM-3	21 ¹ / ₈	8 ³ / ₈	16 ⁵ / ₈	4 ¹ / ₄	25 ¹ / ₂	12 ⁵ / ₈	15 ¹ / ₄	21 ¹ / ₄	1 ¹ / ₂	12
WG-3	EM-1	20 ⁵ / ₈	5 ¹ / ₂	13 ³ / ₈	6	17	13 ³ / ₄	19 ¹ / ₄	25 ¹ / ₄	1 ¹ / ₂	12
WG-3	EM-2	21	8 ¹ / ₈	17 ¹ / ₈	6	23	13 ³ / ₄	16 ⁵ / ₈	22 ¹ / ₂	1 ¹ / ₂	12
WG-3	EM-3	22	8 ³ / ₈	16 ⁵ / ₈	6	24 ¹ / ₂	13 ³ / ₄	16 ⁵ / ₈	22 ¹ / ₂	1 ¹ / ₂	12
WG-3	EM-4	23	9 ¹ / ₂	18 ⁵ / ₈	6	26 ⁵ / ₈	13 ³ / ₄	18 ³ / ₄	27 ¹ / ₂	1 ¹ / ₂	12
WG-4	EM-2	21 ¹ / ₈	8 ³ / ₄	17 ¹ / ₈	7 ³ / ₄	23	9 ³ / ₈	18	24	1 ¹ / ₂	12
WG-4	EM-3	22 ⁵ / ₈	9 ³ / ₈	16 ⁵ / ₈	7 ³ / ₄	24 ¹ / ₂	9 ³ / ₈	17 ¹ / ₄	23 ¹ / ₄	1 ¹ / ₂	12
WG-4	EM-4	23 ⁵ / ₈	10 ³ / ₈	18 ⁵ / ₈	7 ³ / ₄	26 ⁵ / ₈	9 ³ / ₈	19 ³ / ₈	28 ³ / ₈	1 ¹ / ₂	18
WG-5	EM-3	22 ⁷ / ₈	9 ³ / ₈	16 ⁵ / ₈	9 ³ / ₄	24 ¹ / ₄	10 ³ / ₄	18 ³ / ₄	24 ¹ / ₄	1 ¹ / ₂	12
WG-5	EM-4	23 ⁷ / ₈	10 ³ / ₈	18 ⁵ / ₈	9 ³ / ₄	26 ⁵ / ₈	10 ³ / ₄	20 ¹ / ₄	29 ¹ / ₄	1 ¹ / ₂	18
WG-5	EM-5	26 ¹ / ₂	12	21 ¹ / ₄	9 ³ / ₄	33	10 ³ / ₄	22	34	1 ¹ / ₂	24
WG-6	EM-4	25 ³ / ₈	11 ³ / ₈	18 ⁵ / ₈	13	26 ⁵ / ₈	13 ³ / ₈	27 ³ / ₈	36 ³ / ₈	1 ¹ / ₂	18
WG-6	EM-5	28	13 ¹ / ₂	21 ¹ / ₄	13	33	13 ³ / ₈	25 ³ / ₈	37 ³ / ₈	1 ¹ / ₂	24
WG-6	EM-6	30 ¹ / ₄	15	22 ¹ / ₂	13	32 ¹ / ₄	13 ³ / ₈	24 ¹ / ₄	36 ³ / ₈	2	24

PNEUMATIC ACTUATION FOR PRATT NUCLEAR BUTTERFLY VALVES

CYLINDER ACTUATORS DESIGNED SPECIFICALLY FOR NUCLEAR POWER APPLICATIONS

Available pneumatic actuators include spring-opposed air cylinders, double-acting air cylinders and a variety of solenoid valve/accumulator systems which are designed to permit valve operation after the main power supply has failed. Typical opening time for an air cylinder actuated valve in current applications is sixty seconds. Dimensions for double-acting units are available upon request. Dimensions for accessories such as limit switches, control components, junction boxes, etc., are not included but available upon request.

CYLINDER ACTUATOR (BETTIS MODEL T)

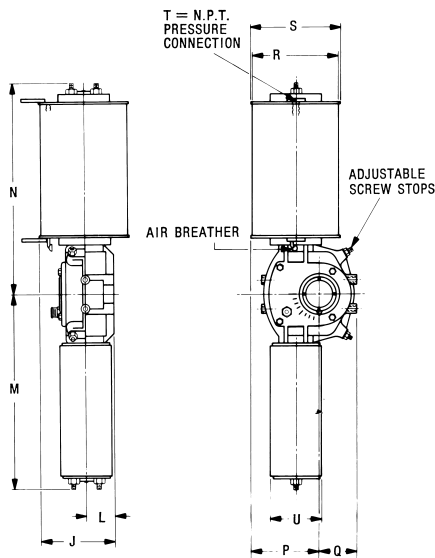

Actuator Size	Dimensions									
	J	L	M	N	P	Q	R	S	T	U
NT-310SR-1	9 ⁷ / ₁₆	3 ¹⁵ / ₁₆	45 ¹³ / ₁₆	23 ⁹ / ₁₆	8 ³ / ₄	3 ³ / ₁₆	10 ³ / ₄	11	1 ¹ / ₂	11 ³ / ₈
NT-316SR-1	12 ¹ / ₁₆	3 ¹⁵ / ₁₆	45 ¹³ / ₁₆	23 ⁹ / ₁₆	10 ¹ / ₁₆	3 ³ / ₁₆	16	16 ¹ / ₄	³ / ₄	11 ³ / ₈
NT-416SR-2	12 ⁵ / ₁₆	4 ³ / ₁₆	47 ³ / ₄	25 ³ / ₄	8 ⁵ / ₈	4 ⁵ / ₈	16	16 ¹ / ₄	³ / ₄	11 ³ / ₈
NT-420SR-2	14 ⁵ / ₁₆	4 ³ / ₁₆	47 ³ / ₄	25 ³ / ₄	1 ¹ / ₈	4 ⁵ / ₈	20	20 ¹ / ₄	³ / ₄	11 ³ / ₈
NT-516SR-1	12 ¹⁵ / ₁₆	4 ¹³ / ₁₆	87	35 ¹ / ₁₆	8 ⁵ / ₈	7 ¹³ / ₁₆	16	16 ¹ / ₄	³ / ₄	13 ³ / ₁₆
NT-520SR-1	15 ¹⁵ / ₁₆	4 ¹³ / ₁₆	87	35 ¹ / ₁₆	10 ⁵ / ₈	7 ¹³ / ₁₆	20	20 ¹ / ₄	³ / ₄	13 ³ / ₁₆
NT-816SR-1	12 ⁵ / ₁₆	4 ³ / ₁₆	89 ⁷ / ₈	43 ⁵ / ₈	8 ⁵ / ₈	7 ¹³ / ₁₆	16	16 ¹ / ₄	³ / ₄	12 ³ / ₄

CYLINDER ACTUATOR (BETTIS MODEL CB)

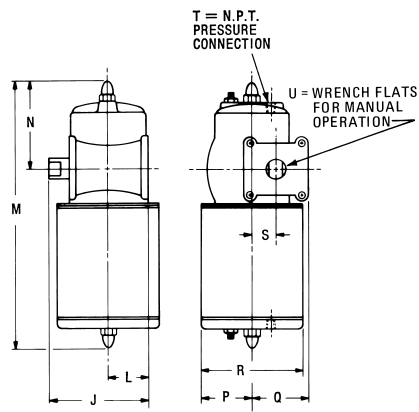

Actuator Size	Dimensions									
	J	L	M	N	P	Q	R	S	T	U
NCB-315SR	4 ²⁵ / ₃₂	1 ¹ / ₈	20 ⁵ / ₁₆	4 ⁹ / ₁₆	1 ⁵ / ₈	4 ⁷ / ₃₂	3 ¹ / ₄	1 ³ / ₃₂	¹ / ₄	⁵ / ₈
NCB-420SR	5 ²¹ / ₃₂	2 ⁵ / ₁₆	24 ⁵ / ₁₆	5 ⁵ / ₈	2 ¹ / ₈	5 ¹ / ₂	4 ¹ / ₄	1 ³ / ₈	³ / ₈	⁷ / ₈
NCB-525SR	7 ¹ / ₄	2 ¹ / ₈	27 ¹ / ₂	6 ³ / ₈	2 ¹ / ₁₆	6 ³ / ₈	5 ³ / ₈	1 ¹ / ₁₆	³ / ₈	1 ¹ / ₈
NCB-725SR	7 ¹ / ₄	2 ¹ / ₈	27 ⁵ / ₈	7 ¹ / ₂	3 ³ / ₄	7 ¹ / ₄	7 ¹ / ₂	1 ¹ / ₁₆	³ / ₈	1 ¹ / ₈

All dimensions shown in inches.

SEISMIC AND OPERABILITY QUALIFICATION

SEISMIC QUALIFICATION

Pratt performs analytical seismic qualification for each size and type of valve/actuator assembly. Seismic qualification methods are as follows:

Static Seismic + DBA Load Analysis

Valve components including the operator support structure are qualified for the faulted conditions concurrent with Safe Shut-down Earthquake Loading applied simultaneously along three major axes, by static analysis as follows:

- 1) Analytical demonstration of the fundamental natural frequency of operator support structure to be above 33 Hz.
- 2) Valve body analysis using body shape rules of ASME Section III, Article NB3500.
- 3) Disc, shaft and other critical components analysis for faulted conditions concurrent with SSE Loading applied simultaneously along three major axes. For Active Safety Related Valves, the stress levels will be maintained below design allowable permitted by the Code. For Non-active, Seismic Category I Valves, the stress levels will be maintained within the code allowable specified for the faulted conditions.
- 4) Seismic input for SSE will be 5g max.

Supplier Certification for Electric Actuators

All electric motor actuators will be certified by suppliers to be adequate for the required service conditions on the basis of tests conducted to date by suppliers, either on analogous or similar units under requirements of IEEE344 and IEEE382 Standards.

Pneumatic Actuator Performance Criteria

All pneumatic actuators will be qualified to be adequate for the required service as follows:

- 1) Actuator shall be assumed as a rigid system and a static analysis will be performed.
- 2) Seismic input for SSE will be 5g max. The actuator component stresses at SSE levels shall not exceed 90% of yield strength of the material.

OPERABILITY ASSURANCE

Pratt offers an Operability Assurance Program for Active Safety Related Valves. In addition to the static load analytical qualification defined under **Seismic**, the Operability Assurance of Active Safety Related valves is demonstrated as follows:

Selection of Test Valve/Operator Assemblies - On the basis of apparent similarity of design features, the test valve/operator assemblies will be selected for testing. The recommended test valve sizes to cover majority of applications are 12", 18" and 36". The extension of qualification from test valve assemblies to the other sizes will be on the basis of similarity of design features.

Test Sequence & Conditions - The test assembly will be subjected to the following sequence of testing:

- 1) *Leakage Test* - A bubble-tight seat leakage test will be performed on all valves at maximum shut-off pressure and room temperature. A shaft leakage test will be performed on all valves at maximum line pressure at room temperature.
- 2) *Cold Cycle Test* - The test assembly will be subjected to three operating cycles under each of minimum and maximum specified motive power conditions. The operating cycle will consist of closing against internal pressure and opening against a differential at room temperature. During the cycle test, the shaft travel time for each direction of travel will be recorded.
- 3) *Hot Cycle Test* - The test assembly will be subject to three operating cycles under each of minimum and maximum specified motive power conditions. The operating cycle will consist of closing against internal pressure and opening against a differential pressure at maximum design temperature. During the cycle test, the shaft travel time for each direction of travel will be recorded.
- 4) *Seismic Test* - The valve/actuator assembly will be installed with shaft in the horizontal position thus representing most severe mounting condition. An equivalent of 5g force will be applied at the approximate center of gravity location of actuator in each of the three major axes followed by a cold cycle test, as described in 2 above. Shaft travel time shall be recorded.
- 5) *Vibration Test* - The test assembly will be subject to a frequency search from 5 to 65 Hz. in each of the three major axes. If no resonant frequencies are detected, the dwell test shall be performed at 33 Hz.

Documentation - The documentation covering this operability assurance will consist of the following:

- 1) Test plans and procedures.
- 2) Recording of pertinent test data; e.g. pressure, temperature and time.
- 3) Observations and conclusions.

Acceptance Standard - A successful testing of the test valve/actuator assemblies will be considered adequate to demonstrate operability of other similar active valves.

SUGGESTED SPECIFICATIONS - ASME CLASS 2 AND 3 NUCLEAR SAFETY RELATED WATER SERVICE BUTTERFLY VALVES

General:

Valve shall be either Henry Pratt Company Series 1100 or Series 1400 or an approved equal. The valves shall be furnished under a current N-Stamp program, as applicable, and comply with the following details.

Valve Models & Sizes:

Pratt 1100 (6" through 36" and larger as required)
Pratt 1400 (3" through 24")

Design Rating:

Standard Pressure Class: ANSI 150 lb. Class

Special Pressure Class:

For valves larger than 24", 75 psig service class, as permitted by ASME Sec. III Code Case 1678, also available.

Maximum Shut-off Pressure, for Bubble-tight Service: 200 psig.

Maximum Normal Service Temperature:

200°F for Pratt 1100 Valves.
300°F for Pratt 1400 Valves.

Maximum Radiation Exposure:

1 x 10⁷ Rad. for Pratt 1100 Valves.
1 x 10⁸ Rad. for Pratt 1400 Valves.

Seismic Rating:

Class 1 for active and non-active services. The upset, emergency or faulted conditions will be analyzed concurrently with 5g seismic load applied simultaneously along three major axes. The stress levels will be maintained within the Code allowables.

Valve Operability Assurance:

The manufacturers shall submit a program for providing the valve operability assurance requirement meeting the intent of NRC Reg. Guide 1.48. The program shall be submitted with the proposal describing the valves to be tested, type of testing and test conditions.

Design Features:

Valve Body: Valve body shall be flanged or prepared for welding to the adjacent pipe. The weld end preparation will be in accordance with the customer's design specifications. Flanges for valves up to 24" will conform to ANSI B16.5. Flanges for valves larger than 24" will be in accordance with Code Case 1678, Code Case 1702 or Code Case 1744 as applicable. Valve bodies with drilled and tapped holes will be suitable for Class 2B, alloy bolt thread series. Flange bolt holes drilled and tapped through entire body thickness are not acceptable. All valves shall be suitable for dead-end service. Wafer style valves are not acceptable.

Valve Disc: The disc shall be of fabricated or cast construction with no external ribs perpendicular to the flow. The carbon steel disc shall have stainless steel seating edge covering the full width of the seating surface. Sprayed or plated seat surfaces are not permissible. The valve disc shall rotate 90° from full open to full closed position. The disc shall be mechanically locked to valve shaft.

Valve Seats: Rubber seats shall be either permanently bonded to the valve body or will be mechanically retained in the valve body without use of threaded fasteners. Seats shall be field adjustable and replaceable, except in the case of rubber-lined bodies and permanently bonded seats. The rubber seat design shall have at least ten years of qualifying experience in similar application and shall have passed cycle life testing in accordance with AWWA C504, Para. 12.4.2. An affidavit of compliance with this testing will be furnished with proposal.

Valve Bearing: Valve bearing shall be sleeve type, installed in the valve body trunnions. Bearing shall be corrosion resistant.

Valve Shaft: The valve shaft may be a one-piece construction extending through valve disc or may be comprised of two-piece shafts inserted into disc hubs (stub shaft). If the shaft is of the two-piece design, each stub shaft shall be inserted in the valve disc hubs for minimum distance of 1° times shaft diameter. The shaft shall be finished to satisfy the requirements of the bearings and packings used. The valve shaft diameter shall not be reduced at the bearing or at the adaptation to the actuator.

Shaft Seals: The packing shall be of the self-adjusting rubber chevron type with a minimum of three rings in a set. The valves normally containing radioactive fluid shall have two independent sets of packing separated by a lantern ring and leak-off connection, tapped "NPT and plugged. Shaft seals shall be replaceable without disturbing any part of the valve or valve actuator assembly.

Actuators: Manual actuators, unless otherwise specified, shall be capable of opening the valve against the design differential pressure and the resulting maximum dynamic torque with not more than 100 lb. pull on the handle or lever. Manual actuators shall have factory set travel limit stops at both ends of travel and shall be designed to withstand, without damage, a pull of 200 lbs. on the handwheel after stops are encountered. Power operated valves shall have actuators sized for maximum differential pressures specified in the design specifications.

Materials of Construction:

Valve Body: Valve body shall be made of materials conforming to SA-216, Gr. WCB or SA-516, Gr. 70.

Valve Disc: Valve disc shall be made of material conforming to SA-216, Gr. WCB or SA-516, Gr. 70. The seating edge of the disc shall be stainless steel. For Pratt 1100 6" and 8" size valves, disc material shall be SA-479, Type 304 Stainless Steel.

Valve Shaft: Valve shaft shall be SA-564, Type 630 (Cond. 1150).

Valve Trim: The elastomeric components of valves, such as packing, seat and O-rings, shall be of material suitable for specified radioactive and temperature service. EPT materials for these components will be preferred.

Materials for Special Applications:

For salt or brackish water service, or for borated water service, or for any other corrosive fluid services, the **valve body** shall be fully rubber-lined with rubber extending over the flange face. The **disc** shall be solid stainless steel conforming to SA-351, CF8M. **Valve shaft** material shall be monel. Other suitable materials currently under consideration by Code will be considered for construction of valves in such services.

Shop Testing:

Fully machined valve bodies shall be hydrostatically tested in accordance with requirement of ASME Sec. III. Tight shut-off of the valve seat in both directions of travel will be demonstrated by testing with air or water in accordance with MSS-SP-67.

Fully assembled valves shall be cycled, opened and closed three times without pressure across the disc, to check proper functioning of the operators and proper setting of travel limit stops. Electric actuators shall be checked for conformance to speed of closure requirements, with a minimum specified motive power, in the design specifications.

SUGGESTED SPECIFICATIONS - ASME CLASS 2 AND 3 NUCLEAR SAFETY RELATED AIR SERVICE BUTTERFLY VALVES

General:

Valve shall be either Henry Pratt Company Series 1200 or an approved equal. The valves shall be furnished under a current N-Stamp program, as applicable, and comply with the following details.

Valve Models & Sizes:

Pratt 1200 (6" through 48")

Design Rating:

Standard Pressure Class: ANSI 150 lb. Class for valves up to 24"

Standard Pressure Class:

For valves larger than 24", 75 psig service class, as permitted by ASME Sec. III Code Case 1678.

Maximum Shut-off Pressure, for Bubble-tight Service:

200 psig for valves up to 24"; 75 psig for valves above 24".

Maximum Normal Service Temperature: 300°F .

Maximum Faulted Condition Temperature: 350°F .

Maximum Radiation Exposure: 1 x 10⁸ Rad.

Seismic Rating:

Class 1 for active and non-active service. The upset emergency or faulted conditions will be analyzed concurrently with 5g seismic load applied simultaneously along three major axes. The stress levels will be maintained within the Code allowables.

Valve Operability Assurance:

The manufacturers shall submit a program for providing the valve operability assurance requirement meeting the intent of NRC Reg. Guide 1.48. The program shall be submitted with the proposal describing the valves to be tested, type of testing and test conditions.

Design Features:

Valve Body: Valve body shall be flanged or prepared for welding to the adjacent pipe. The weld end preparation will be in accordance with the customer's design specifications. Flanges for valves up to 24" will conform to ANSI B16.5. Flanges for valves larger than 24" will be in accordance with Code Case 1678, Code Case 1702 or Code Case 1744 as applicable. Valve bodies with drilled and tapped holes will be suitable for Class 2B, alloy bolt thread through entire body thickness are not acceptable. All valves shall be suitable for dead-end service. Wafer style valves are not acceptable.

Valve Disc: Valve disc shall be of fabricated or cast steel construction with no external ribs perpendicular to the flow. The disc shall rotate 90° from full open to full close position. The disc shall be mechanically locked with the valve shaft.

Valve Seats: Rubber seats shall be either mechanically retained on the valve disc. The seat shall be adjustable and replaceable with access from flanged end of the valve. This rubber seat shall be suitable for specified conditions of pressure, temperature and radiation.

Valve Shaft:

The valve shaft may be a one-piece construction extending through valve disc or may be comprised of two piece shafts inserted into the disc hubs (stub shaft). If the shaft is of the two-piece design, each stub shaft shall be inserted in the valve disc hubs for minimum distance of 1" times shaft diameter. The shaft shall be finished to satisfy the requirements of the bearings and packing used. The valve shaft diameter shall not be reduced at the bearing or at the adaption of the actuator.

Valve Trim: The elastomeric components of valves, such as packing, seat and O-rings, shall be of material suitable for specified radioactive and temperature service. EPT materials for these components will be preferred.

Valve Bearing: Valve bearing shall be sleeve-type or roller bearing type, installed in the valve body trunnions. Bearing shall be corrosion resistant. If lubrication is required, accessible fitting shall be provided.

Shaft Seals: The packing shall be of the self-adjusting rubber chevron type with a minimum of three rings in a set. The valves normally containing radioactive fluid shall have two independent sets of packing separated by a lantern ring and a leak-off connection, tapped "N" NPT and plugged. Shaft seals shall be replaceable without disturbing any part of the valve or valve actuator assembly.

Actuators: Manual actuators, unless otherwise specified, shall be capable of opening the valve against the design differential pressure and the resulting maximum dynamic torque with not more than 100 lb. pull on the handle or lever. Manual actuators shall have factory set travel limit stops at both ends of travel and shall be designed to withstand, without damage, a pull of 200 lbs. on the handwheel after stops are encountered.

Power operated valves shall have actuators sized for maximum differential pressures, specified in the design specifications.

Materials of Construction:

Valve Body: Valve body shall be constructed of material conforming to SA-516, Gr. 70.

Valve Disc: Valve disc shall be of material conforming to SA-516, Gr. 70. The seating surface which contacts the rubber seat shall be SA-479, Type 304 welded either to the valve body or to the valve disc. Code Case 1516 may be invoked for welding of seats.

Valve Shaft: Valve shaft shall be SA-564, Type 630 (Cond. 1150).

Valve Trim: The rubber seat and all other elastomeric materials for components, such as packing and O-rings, shall be suitable for continuous operations at design temperature and radiation conditions. Sealing shall be unimpaired by radiation exposure up to 1 x 10⁸ Rad. EPT materials for these components will be preferred.

Shop Testing:

Fully machined valve bodies shall be hydrostatically tested in accordance with the requirements of ASME Sec. III. Tight shut-off of valve seat in both directions of travel will be demonstrated by bubble-tight testing with air in accordance with MSS-SP-67. Equivalent seat leakage shall not be greater than 2cc air per hour, per inch of nominal valve size at specified operating pressure.

The valves shall be tested at the maximum specified differential pressure and at some lower pressure to demonstrate that pressure-assisted sealing is not required for tight shut-off. A "go-no go" test may be substituted for a qualitatively measured leak test if the manufacturer demonstrates empirically that the "go-no go" test is sufficiently sensitive to indicate when acceptable leak rate is exceeded.

Fully assembled valves shall be cycled, opened and closed three times without pressure across the disc to check proper functioning of the actuators and proper setting of the travel limit stops. Power actuators shall be checked for conformance to speed of closure requirements, with a minimum specified motive power, in the design specifications.

Pratt History >

Engineering >

Products >

Specifications >

<http://www.henrypratt.com/>

PRATT PRODUCT GUIDE

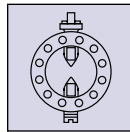

Model 2FI

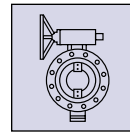

Triton HP250

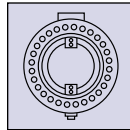

Triton XR70



Control Systems

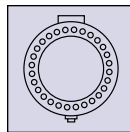

Triton XL

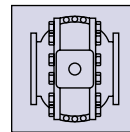

Metal Seated Ball Valve

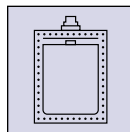

Rectangular

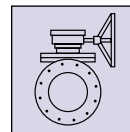

Plug Valve

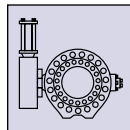

Rubber Seated Ball Valve

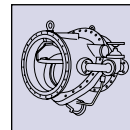

Tilting Disc Check Valve

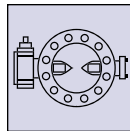

Groundhog Valve

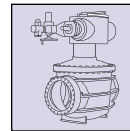

Fixed Cone Valve

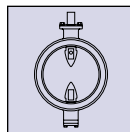

Monoflange MKII

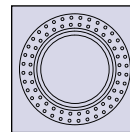

Sleeve Valve

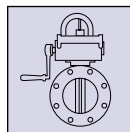

Indicating Butterfly Valve
UL & FM approved

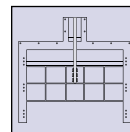

Sluice Gate

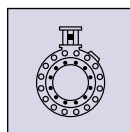

N-Stamp Nuclear Butterfly Valve

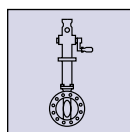

PIVA Post Indicating Valve Assembly
UL & FM approved

PRATT

Henry Pratt Company

401 South Highland Avenue

Aurora, Illinois 60506-5563

Toll Free 877-436-7977

630-844-4000

Fax 630-844-4160

www.henrypratt.com

©2002 Henry Pratt Company

Printed in the U.S.A.

NUK-0902

