

*Jdv*

TOOLS FOR TELECOM &  
ELECTRONIC ASSEMBLY



## WIRE WRAPPING TOOLS & ACCESSORIES

• Wire Wrapping Guns .....	4-6
• Bits and Sleeves .....	7-9
• Hand Wrapping and Unwrapping Tools .....	10-12
• Semi-Automatic Wire Wrapping Systems .....	13
• Wire .....	14
• Wire Wrap Tool Kits .....	16
• Wire Strippers .....	18-19

## FIBER OPTIC & CABLE TOOLS

• Patch Cords / Connectors .....	20
• Cleaning .....	21
• Cleavers .....	22
• Cutting Shears .....	23
• Cable Strippers .....	24-25
• Cable Reel & Reel Saver .....	26
• Heavy Duty Utility Knives .....	26

## HAND TOOLS

• Ceramic Adjustment Tools .....	28
• Precision Screwdrivers .....	29
• Megadora Screwdrivers .....	30
• Power Grip Screwdrivers .....	31
• Ball Grip Screwdrivers .....	32
• Hex Wrenches .....	33

## 1000V INSULATED HAND TOOLS

• Sockets .....	34
• Ratchets & Extensions .....	35
• Wrenches .....	36
• Screwdrivers .....	37
• Pliers & Cutters .....	38
• Tool Sets .....	39-40

## INDUSTRIAL BITS

• Bit Holders .....	41
• Insert Bits .....	41
• 4mm Shank Drive .....	42
• 5mm Shank Drive .....	43
• 4mm Drive .....	43
• 1/4" (6.35mm) Drive .....	44-46
• 5mm Drive .....	46

## PNEUMATIC TOOLS

• Screwdrivers .....	47-48
• Impact Wrenches .....	48-49
• Scraper & Accessories .....	50
• Saws & Blades .....	50
• Blow Guns .....	50
• Cutters & Blades .....	51
• Crimping Tools & Accessories .....	52

## STAT<sup>⚡</sup>BUSTER STATIC ELIMINATORS

• Small and Compact .....	53-54
• Hand-Held .....	55
• Clip-Mounted .....	56
• Bench-Top .....	57
• Replacement Parts .....	58
• Static Locator .....	59

# The Technology of Wire Wrapping

A wire wrapped connection is made by coiling the wire around the sharp corners of a terminal under mechanical tension. This method of connection was developed by Bell Telephone Laboratories, Western Electric Company.

## Five Steps To Make A Wire Wrap Connection

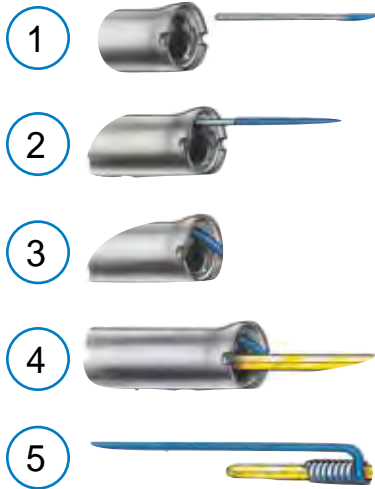

## Regular



## Modified



A "Regular" bit wraps the bare wire around the terminal. A "Modified" bit wraps a portion of insulation around the terminal in addition to the bare wire. This greatly increases the ability to withstand vibration.

A distinct advantage of wire wrapping is the ease with which a wire may be removed from a terminal to correct errors or modify wiring. An unwrap tool is slipped over the terminal, engaging the first turn of the connection. Rotating the tool, the connection is removed in seconds, without damage to the terminal.

## Wire Size Chart

Bare Wire Dia.		AWG (USA)	SWG (GB)
In.	mm		
.0403	1.022	18	
.040	1.016		19
.036	0.914	19	20
.032	0.813	20	21
.028	0.711	21	22
.0253	0.643	22	
.024	0.61		23
.0226	0.574	23	
.022	0.559		24
.0201	0.51	24	
.020	0.508		25
.018	0.457		26
.0179	0.455	25	
.0164	0.417		27
.0159	0.404	26	
.0148	0.376		28
.0142	0.361	27	
.0136	0.345		29
.0126	0.320	28	
.0124	0.315		30
.0116	0.295		31
.0113	0.287	29	
.0108	0.274		32
.0100	0.254	30	33
.0092	0.234		34
.0089	0.225	31	
.0084	0.213		35
0.008	0.203	32	

## "Strip" Force Chart\*

Wire Size			Min. Number of Turns (Bare Wire)	Min. Strip Force	
AWG	Dia (in)	Dia. (mm)		lbs.	g
16	.0510	1.30	4	15	6800
18	.0403	1.00	4	15	6800
20	.0320	0.80	5	8	3600
22	.0253	0.65	5	8	3600
24	.0201	0.50	6	7	3200
26	.0159	0.40	7	6	2700
28	.0126	0.32	7	5	2200
30	.0100	0.25	7	3.3	1500

\* Conforms to MIL-STD-1130B

There is a constant surveillance of manufacturing dimensions. Each wrapping bit is subjected to a series of "Qualification Tests". These consist of wrapping groups of wire on various types of terminals. The wrapped wires are then subjected to a "strip" test to determine adequate tightness. "Unwrap" tests are also performed to ensure against an "Over Tight" wrap.

Solid wire is used for wire wrapped connections. Copper is the most commonly used wire. Minimum elongation of 15% is required for 24 through 32 AWG; 20% for larger wire.

## Terminal Diagonal Chart

In.	.010	.015	.020	.025	.030	.035	.040	.045	.050	.055	.060	.065	.070	.075	.080	.085	.090	.095	.100
mm	0.25	0.38	0.51	0.64	0.76	0.89	1.02	1.14	1.27	1.40	1.52	1.65	1.78	1.91	2.03	2.16	2.29	2.41	2.54
.010	.014	.018	.022	.027	.032	.036	.041	.046	.051	.056	.061	.066	.071	.076	.081	.086	.091	.096	.101
0.25	0.36	0.46	0.56	0.69	0.81	0.91	1.04	1.17	1.30	1.42	1.55	1.68	1.80	1.93	2.06	2.18	2.31	2.44	2.57
.015	.018	.021	.025	.029	.033	.038	.043	.047	.052	.057	.062	.067	.072	.077	.082	.087	.092	.097	.102
0.38	0.46	0.53	0.64	0.74	0.84	0.97	1.09	1.19	1.32	1.45	1.58	1.70	1.83	1.96	2.08	2.21	2.34	2.46	2.59
.020	.022	.025	.028	.032	.036	.040	.045	.049	.053	.058	.063	.068	.073	.078	.083	.088	.093	.098	.103
0.51	0.56	0.64	0.71	0.81	0.91	1.02	1.14	1.25	1.35	1.47	1.60	1.73	1.85	1.98	2.11	2.24	2.36	2.49	2.62
.025	.027	.029	.032	.035	.039	.043	.047	.050	.056	.060	.065	.069	.074	.079	.084	.089	.094	.099	.104
0.64	0.69	0.74	0.81	0.89	0.99	1.09	1.19	1.27	1.42	1.52	1.65	1.75	1.88	2.01	2.13	2.26	2.39	2.52	2.64
.030	.032	.033	.036	.039	.042	.046	.049	.052	.058	.062	.067	.071	.076	.080	.085	.090	.095	.100	.105
0.76	0.81	0.84	0.91	0.99	1.07	1.17	1.27	1.37	1.47	1.58	1.70	1.80	1.93	2.03	2.16	2.29	2.41	2.54	2.67
.035	.036	.038	.040	.043	.046	.049	.052	.056	.060	.064	.069	.073	.078	.082	.087	.091	.096	.101	.106
0.89	0.91	0.97	1.02	1.09	1.17	1.25	1.32	1.42	1.52	1.63	1.75	1.85	1.98	2.08	2.21	2.31	2.44	2.57	2.69
.040	.041	.043	.045	.047	.050	.052	.056	.060	.064	.068	.072	.076	.080	.084	.089	.092	.097	.102	.107
1.02	1.04	1.09	1.14	1.19	1.27	1.32	1.42	1.52	1.63	1.73	1.83	1.93	2.03	2.13	2.26	2.34	2.46	2.59	2.72
.045	.046	.047	.049	.050	.054	.056	.060	.063	.067	.071	.074	.078	.083	.087	.091	.096	.101	.105	.109
1.14	1.17	1.19	1.25	1.27	1.37	1.42	1.52	1.60	1.70	1.80	1.88	1.98	2.11	2.21	2.31	2.44	2.57	2.67	2.77
.050	.051	.052	.053	.056	.058	.060	.064	.067	.071	.074	.078	.082	.086	.090	.094	.098	.103	.107	.111
1.27	1.30	1.32	1.35	1.42	1.47	1.52	1.63	1.70	1.80	1.88	1.98	2.08	2.18	2.29	2.39	2.49	2.62	2.72	2.82



## Manual Wire Wrapping Guns

**GETTING SHOCKED?**



**WG200-R3278**  
(Lexan®)

**WG100R3278INS-S**  
(Aluminum)

The WG200-R3278 wrapping gun is lightweight and is used for both regular and modified wraps, and is made of high quality Lexan®. The all-metal gear drive system ensures reliability and longevity providing high quality wire wrapped connections. These tools can accommodate a full line of bits and sleeves ranging from 22-32 AWG (0.64 - 0.20mm). The WG200-R3278 manual wrapping guns are ideal for jobs without a convenient power source.

The WG100R3278INS-S is an ergonomic tool that is designed with a Chuck style nose-piece to accommodate JDV's full line of bits and sleeves ranging from 22-32 AWG (0.64 - 0.20mm). It is equipped with a special housing which helps to protect operators while working with dangerous voltage. This wrapping gun is made of high quality aluminum and the gear train is more reliable and far exceeds other manufacturers.

Part No	Insulation	Housing Type	Nose Piece
<b>WG800</b>	<b>FULL</b>	Aluminum w/Dielectric Coating	Chuck
<b>WG100R3278INS-S</b>	Partial	Aluminum w/Dielectric Coating	Chuck
<b>WG200-R3278</b>	Partial	Lexan®	Chuck

See Pages 8-9 for Bits & Sleeves Selection



Then try  
**JDV's INSULATED**  
**Wire Wrapping Tool!**

JDV Products developed a **FULLY INSULATED** Manual Wire Wrap Tool (model WG800) that stops electrical currents right at the source!

By insulating the barrel of the wrap gun, electrical current cannot enter the tool, which helps to protect telephone technicians from getting shocked or injured through the wrapping gun while making wire wrap connections on hot circuits.

The WG800 is designed with a rugged aluminum housing with orange dielectric coating, a solid Chuck-style nose-piece, and accommodates JDV's full line of wrap bits and sleeves ranging from 22-32 AWG (0.64-0.20mm).

JDV's WG800 has been found to meet UL Safety Requirement. The test was provided by Third Party Laboratory and Certified to 1000V A/C under Dielectric testing condition IAW UL Standard.

**NEED LIGHT?**



Don't forget JDV's FL100 LED Light Bracket  
See page 15 for details

## Manual Wire Unwrapping Gun

JDV's WG100-R3394INS wire unwrapping gun is made of high quality aluminum housing and has a coating that ensures safety for the operator when doing unwrapping applications in high voltage environments. Like JDV's other manual guns, this tool comes in a Chuck style model and can be used with JDV's unwrap bits and sleeves from 22-32 AWG (0.64-0.20 mm).

Part No	Insulation	Housing Type	Nose Piece
<b>WG100-R3394INS</b>	Partial	Aluminum w/ Dielectric Coating	Chuck

Kit Part No	Sleeve P/N	Unwrap Bit P/N	Collet Style	Wire Size		Terminal Hole	
				Inch	mm	Inch	mm
<b>UP70</b>	SP171	BU70	Chuck	22-26	0.65-0.40	0.07	1.77
<b>UP36</b>	SP171	BU36	Chuck	24-32	0.50-0.20	0.036	0.96



JDV Products, Inc • 22-01 Raphael Street • Fair Lawn, NJ 07410 USA  
201-796-1720 • Fax 201-796-9399 • www.jdvproducts.com

## 120V Electric Wire Wrapping & Unwrapping Tools

- Fast Operation
- Ergonomically Designed
- Lightweight Lexan Housing
- Unique Positive Indexing Mechanism
- Standard 20 Foot Power Cord
- Two and Three Wire Version
- 90 Day Warranty



The 120 Volt 6000 series electric wire wrapping and unwrapping tools have been designed for production and field service operations where wire sizes 18 to 32 AWG are used. The lightweight Lexan housing and the design of the handle greatly reduce problems normally experienced in repetitive motion injuries, such as carpal tunnel syndrome. All our wire wrapping tools have a geared drive, a positive indexing mechanism, and a quality electric motor which requires no maintenance. The 6000 series comes with a light-pull trigger, a high speed motor (4000 rpm), and a standard 20 foot power cord for optimum usage range from an electrical outlet. For the inexperienced operator, we offer the anti-back force version (ABF) of the tool. The ABF version is designed so that, when the operator pulls the trigger, the bit retracts inside the sleeve, causing a symmetrical wrap to be achieved on the post. The ABF tools are used mostly for training and for the customers who use the tool so infrequently that they do not remember the technique. All the electric wire wrapping tools are designed, developed, and manufactured in our ISO approved plant.

### ACCESSORIES

See pages 6-8 to find a complete list of wire wrapping bits and sleeves including Cut, Strip & Wrap bit/sleeve or manual wire wrapping tools or manual unwrapping tools.

### SPECIFICATIONS

PART NO.	VOLTAGE	TYPE	CORD	FREE SPEED (RPM)	WEIGHT	
					oz	kg
<b>WRAPPING</b>						
SP 6021	115	STANDARD	3W	4000	12	0.34
SP 6022	115	ABF	3W	4000	12	0.34
<b>UNWRAPPING</b>						
SP 6024	115	N/A	3W	1000	15	0.43

### UNWRAPPING BITS FO ELECTRIC TOOLS

PART NO.	WIRE SIZE	TERM HOLE DIAMETER		TERM HOLE DEPTH		BIT O.D.	
		in	mm	in	mm	in	mm
SP 66692	20-26 AWG	0.070	1.78	1.0	25.4	1.125	3.18
SP 66693	26-32 AWG	0.040	1.02	1.0	25.4	0.093	2.36



Part No. 66692 & 66693

## 220V & 48V Electric Wire Wrapping & Unwrapping Tools

- Fast Operation
- Ergonomically Designed
- Lightweight Lexan Housing
- Unique Positive Indexing Mechanism
- Standard 20 Foot Power Cord
- TUV/VDE Approved with CE Marking
- 90 Day Warranty



The 48 and 220 Volt 6000 series electric wire wrapping and unwrapping tools have been designed for production and field service applications where wire sizes from 18 to 32 AWG are used.

The lightweight Lexan housing and the design of the handle greatly reduce the problems normally experienced in repetitive motion injuries, such as carpal tunnel syndrome. All our tools have a geared drive, a positive indexing mechanism, and a quality electric motor which requires no maintenance. The 6000 series comes with a light-pull trigger, a high speed motor (4000 rpm), and a standard 20 foot power cord for optimum usage range from an electrical outlet. Our Models SP 6311, SP 6312, and SP 6314 are all TUV/VDE approved and carry the CE marking. For the inexperienced operator, we offer an anti-backforce (ABF) version of the tool. The ABF version is designed for the bit to retract inside the sleeve when the operator pulls the trigger, causing a symmetrical wrap to be achieved on the post. The ABF tools are mostly used for training and for the customers who uses the tool so infrequently that they do not remember the technique. All the electric wire wrapping tools are designed, developed, and manufactured in our ISO approved plant.

### ACCESSORIES

See pages 6-8 to find a complete list of wire wrapping bits and sleeves including Cut, Strip & Wrap bit/sleeve or manual wire wrapping tools or manual unwrapping tools.

### SPECIFICATIONS

PART NO.	VOLTAGE	TYPE	CORD	FREE SPEED (RPM)	WEIGHT	
					oz	kg
<b>WRAPPING</b>						
SP 6081	48	STANDARD	2W	4000	12	0.34
SP 6082	48	ABF	2W	4000	12	0.34
SP 6311*	220	STANDARD	2W	4000	15	0.43
SP 6312*	220	ABF	2W	4000	15	0.43
<b>UNWRAPPING</b>						
SP 6084	48	N/A	2W	1000	12	0.34
SP 6314*	220	N/A	2W	4000	15	0.43

### UNWRAPPING BITS FOR ELECTRIC TOOLS

PART NO.	WIRE SIZE	TERM HOLE DIAMETER		TERM HOLE DEPTH		BIT O.D.	
		in	mm	in	mm	in	mm
SP 66692	20-26 AWG	0.070	1.78	1.0	25.4	1.125	3.18
SP 66693	26-32 AWG	0.040	1.02	1.0	25.4	0.093	2.36



Part No. 66692 & 66693

## Pneumatic Wire Wrapping Tools

- Lightweight Tool
- Low Air Consumption
- Unique Indexing Mechanism
- Glass-Filled Nylon Housing
- 90 psig Air Pressure
- 90 Day Warranty



Models SP 6001 and SP 6002 are designed for mass production and aircraft maintenance applications. Both models are manufactured from a lightweight, high impact resistant, glass-filled nylon. These tools are lightweight, well balanced, and built to handle the rigors of everyday manufacturing requirements. The handle design reduces operator fatigue, and the high speed (4500 rpm) motor produces fast, efficient wraps for 18 to 32 awg wire sizes. The tools are available in standard and anti-backforce (ABF) versions. These models are designed, developed, and manufactured in our ISO approved plant.

### ACCESSORIES

Wire Wrapping Bits and Sleeves see pages 6-7  
 CSW (Cut/Strip/Wrap) Bits see page 8  
 Cut/Strip Tool Attachment see below

### SPECIFICATIONS

PART NO.	TYPE	FREE SPEED (RPM)	WEIGHT	
			oz	kg
<b>WRAPPING</b>				
SP 6001	STANDARD	4500	9.0	0.26
SP 6002	ABF	4500	9.5	0.27

HOSE PART NO.	LENGTH	I.D.	THREAD CONNECTION
<b>AIR HOSES*</b>			
SP 3406	6'	3/16"	1/8" Male NPT
SP 3606	6'	1/4"	1/8" Male NPT

\* Air Hoses: A high quality hose, constructed of single braid Neoprene, is available by calling our Sales Office.

## Cut & Strip Tool Attachment

The Model 650 is designed to be attached to our 6021, 620 and 6001, plus any of the models in between. The Model SP 650 allows the operator to cut to length and strip the wire in one simple operation. The length of the wire to be cut is adjustable. Different gauge stripping blades can be interchanged quickly and easily. Model SP 654 is a modified version of Model SP 650, except that Model SP 654 only cuts the wire. Model SP 654 is generally used by operators who are using CSW and need only to cut the wire; it does not strip the wire.



### STRIPPING BLADES

WIRE SIZE	PART NO.	WIRE SIZE	PART NO.
20 AWG	64520	28 AWG	SP 64528
22 AWG	64522	30 AWG	SP 64530
24 AWG	64524	22-24 AWG	SP 64533
26 AWG	64526		

# Pneumatic Wire Wrapping Guns

## WG300 Series

### Pneumatic Wire Wrap Guns

The WG300 is not only perfectly balanced, but it is also the lightest pneumatic wire wrap tool available. The WG300 is rated for heavy duty application wrapping 18 AWG wire, yet it is the ideal tool for delicate 32 AWG work.



Part No	Type	Speed/ RPM	Weight		Wire Size	
			Oz	g	AWG	mm
WG300	Standard	4500	110	300	18-32	1.0-0.20
WG300BF	Backforce	4500				

These tools are designed to operate at 80-110psi (6-7 BAR)

## WG400 Series

### Triggerless Wire Wrap Guns

The triggerless WG400 air wire wrap tool is designed for high production environments. It's ergonomic design helps reduce wire wrapping muscle fatigue. When combined with the WAC400 air logic controller, this triggerless tool uses a 3 psi back-pressure signal to activate the tool. The slightest movement of the thumb over a small air sensor hole signals the WAC400 to activate the WG400.



Part No	Type	Speed/ RPM	Weight		Wire Size	
			Oz	g	AWG	mm
WG400	Standard	4500	110	300	18-32	1.0-0.20
WG400BF	Backforce	4500				

## Repair Program

Do you need a good repair center for your JDV pneumatic wrapping guns? If so, then we can help! JDV offers an excellent repair program on all of our pneumatic wire wrapping tools. Simply call JDV, ask for a RMA# (Return Materials Authority) and write this on the outside of the box, and send the unit back to JDV with attention to Repair Dept.

## Accessories



### WAC400

Air Logic Controller

(For use with WG400 Pneumatic Wire Wrap Gun)

Cut/Strip/Wrap Bits on Page 7

Bits & Sleeves on Pages 8-9



### A-10738

6' Nylon Braided Hose

For use with both WG300 & WG400 wire wrapping guns



JDV Products, Inc • 22-01 Raphael Street • Fair Lawn, NJ 07410 USA  
201-796-1720 • Fax 201-796-9399 • www.jdvproducts.com

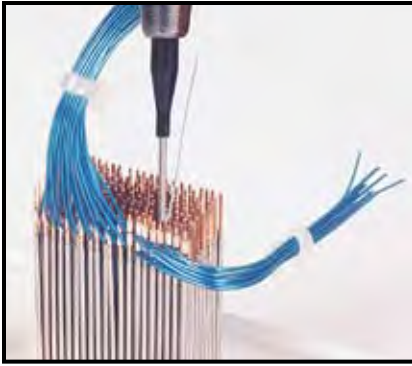

## MICRO BIT WIRE WRAPPING TOOL - 7500 SERIES

JDV Products Inc. introduces the series 5000 and series 7500 Micro-Bit wire wrapping and unwrapping tools. These tools are designed for wrapping wire on .016 in. (0.4mm) square terminals in high-density connectors with pin center distances of .050 in. and .075 in. (1.27mm and 1.9mm).

The 7500 series is designed to work with .075 in. (1.9mm) pin spacing and are conventional wire wrap tools.

Both series are very small tools and require extra care when wire wrapping these applications.



Part No	Pin Distance		Pin Size Inch	Wire Diameter		Retaining Sleeve Part No	Wrap Type
	Inch	mm		AWG	mm		
BMH7528	0.075	1.90	0.016 SQ	28	0.032	S75	MODIFIED
BMH7530	0.075	1.9	0.016 SQ	30-32	0.20-0.25	S75	MODIFIED

BMH7530  
w/ S75

## MICRO WIRE WRAPPING HAND TOOL



Part No	Pin Distance		Pin Size Inch	Wire Diameter		Wrap Type
	Inch	mm		AWG	mm	
HR5030	0.050	1.27	0.016 SQ	30-32	0.20-0.25	REGULAR
HM7528	0.075	1.9	0.016 SQ	28	0.32	MODIFIED
HM7530	0.075	1.9	0.016 SQ	30-32	0.20-0.25	MODIFIED

## UNWRAP TOOL



Part No	Terminal Hole Diameter		Terminal Hole Depth	
	Inch	mm	Inch	mm
UHD5075	0.022	0.56	0.50	12.70

## CSW (Cut/Strip/Wrap) Bits

JDV's NEW open-faced CSW bit is fast and easy to use. It cuts, strips, and wraps the wire in one simple operation. There is no need for wire preparation since this tool can wrap wire directly from a reel or harness.

\* For a demonstration video, please visit our website



Head Part No	Power Tool Holder	Wire Size			Term. Hole Diameter		Term. Hole Depth		Strip Length		Head Diameter		Min. Spacing Terminal	
		AWG	SWG	mm	In.	mm	In.	mm	In.	mm	In.	mm	In.	mm
CSWB24	CSWH-1	24	25	0.50	0.07	1.78	1.000	25.40	1.62	41.10	0.24	6.10	0.16	3.90
CSWB24-4C	CSWH-1	24	25	0.50	0.07	1.78	0.354	9.02	-	-	0.305	7.75	-	-
CSWB26	CSWH-1	26	23	0.40	0.07	1.78	1.000	25.40	1.62	41.10	0.24	6.10	0.16	3.90
CSWB26-4B	CSWH-1	26	25	0.50	0.07	1.78	0.354	9.02	-	-	0.305	7.75	-	-

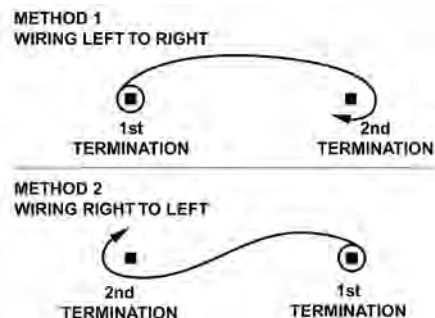
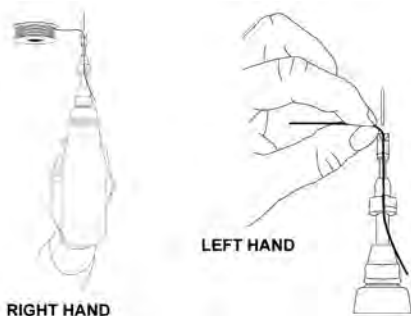

# Modified Wire Wrapping Bits and Sleeves



All Bits & Sleeves are Fully Compatible with any Make or Model Wire Wrapping Tool

AWG (inches)						BIT PART No.	SLEEVE PART No.	METRIC (mm)					
Wire Gauge (AWG)	Max Insulation Diameter	Min/Max Terminal Diagonal	Terminal Hole Depth	Effective Radius	Terminal Hole Diameter			Terminal Hole Diameter	Effective Radius	Terminal Hole Depth	Min/Max Terminal Diagonal	Max Insulation Diameter	Wire Gauge (mm)
20	.058	.042/.073	1.000	.150	.075	BM20	S194LN	1.90	3.81	25.40	1.07/1.85	1.47	0.80
22	.054	.049/.074	1.000	.132	.075	BM22	S171	1.90	3.35	25.40	1.24/1.87	1.37	0.65
22-24	.050	.049/.074	1.250	.121	.075	BM224	S171	1.90	3.07	31.75	1.24/1.87	1.27	.50-.65
24	.046	.054/.073	1.750	.117	.075	BM24DD	S171	1.90	2.97	44.50	1.37/1.87	1.17	0.50
24	.044	.024/.043	0.750	.098	.044	BM2444*	S125LN*	1.11	2.48	19.05	0.60/1.09	1.11	0.50
24	.046	.054/.073	0.750	.118	.075	BM24	S171	1.90	2.99	19.05	1.07/1.85	1.17	0.50
24-26	.046	.054/.073	0.750	.118	.075	BM2426	S171	1.90	2.99	19.05	1.37/1.85	1.17	.40-.50
26	.031	.023/.038	0.750	.075	.040	BM2640*	S93*	1.02	1.90	19.05	0.58/0.96	0.79	0.40
26	.046	.054/.073	1.000	.118	.075	BM26	S171	1.90	2.99	25.40	1.37/1.85	1.17	0.40
26	.044	.028/.044	0.750	.098	.044	BM2644*	S125LN*	1.11	2.48	19.05	0.71/1.12	1.11	0.40
26	.042	.053/.068	1.000	.109	.069	BM2669	S159	1.75	2.77	25.40	1.34/1.72	1.04	0.40
26	.050	.053/.068	1.125	.118	.069	BM26D	S171	1.75	2.99	28.50	1.34/1.72	1.27	0.40
28	.030	.031/.035	0.750	.066	.036	BM28*	S93*	0.91	1.67	19.05	0.79/0.89	0.76	0.32
28	.030	.031/.035	1.125	.066	.036	BM28-1125*	S93*	0.91	1.67	28.57	0.79/0.89	0.76	0.32
28	.030	.031/.035	1.250	.066	.036	BM28-1250*	S93*	0.91	1.67	31.75	0.79/0.89	0.76	0.32
28	.034	.053/.068	1.000	.103	.070	BM2870	S159	1.78	2.61	25.40	1.35/1.72	0.86	0.32
28-29	.036	.033/.038	0.750	.091	.040	BM2840*	S125*	1.02	2.31	19.05	0.83/0.96	0.91	.29-.32
30	.023	.030/.035	0.750	.061	.036	BM30SW*	S93*	.091	1.54	19.05	.099/1.06	0.58	0.25
30	.027	.031/.035	0.750	.064	.043	BM3043*	S93*	1.09	1.62	19.05	0.79/0.89	0.69	0.25
30	.027	.031/.035	0.750	.064	.036	BM30*	S93*	0.91	1.62	19.05	0.79/0.89	0.68	0.25
30	.027	.031/.035	1.125	.064	.036	BM30-1125*	S93*	0.91	1.62	28.57	0.79/0.89	0.68	0.25
30	.023	.030/.035	0.750	.064	.036	BM30SI*	S93*	0.91	1.62	19.05	0.76/0.89	0.58	0.25
30	.027	.060/.064	1.000	.106	.066	BM3066	S159	1.67	2.70	25.40	1.52/1.62	0.69	0.25
30	.027	.027/.030	0.750	.066	.031	BM3031*	S93*	0.79	1.67	19.05	0.69/0.76	0.69	0.25
30-32	.027	.034/.038	0.750	.064	.040	BM3040*	S93*	1.02	1.62	19.05	0.86/0.96	0.69	.20-.25
30-32	.029	.062/.065	1.000	.100	.067	BM3068	S125LD	1.70	2.54	25.40	1.57/1.65	0.74	.20-.25

\* These tools are recommended for .025" square terminals on 0.100 centers / 0.63 mm on 2.54 mm centers.

## Insulated Sleeves

To order insulated sleeves, please specify insulation color on the end of the standard sleeve part number. (i.e. S171R: R=red, B=blue, Y=yellow, G=green, W=white).



JDV Products, Inc • 22-01 Raphael Street • Fair Lawn, NJ 07410 USA  
201-796-1720 • Fax 201-796-9399 • www.jdvproducts.com

# Regular Wire Wrapping Bits and Sleeves



All Bits & Sleeves are Fully Compatible with any Make or Model Wire Wrapping Tool

AWG (inches)						BIT PART No.	SLEEVE PART No.	METRIC (mm)					
Wire Gauge (AWG)	Max Insulation Diameter	Min/Max Terminal Diagonal	Terminal Hole Depth	Effective Radius	Terminal Hole Diameter			Terminal Hole Diameter	Effective Radius	Terminal Hole Depth	Min/Max Terminal Diagonal	Max Insulation Diameter	Wire Gauge (mm)
18	N/A	.060/.073	1.000	.150	.075	BR18	S194	1.90	3.81	25.40	1.52/1.85	N/A	1.00
19	N/A	.042/.073	1.000	.123	.075	BR19	S171	1.90	3.12	25.40	1.07/1.85	N/A	0.91
19-20	N/A	.091/1.122	1.000	.150	.125	BR1920L	S212	3.17	3.81	25.40	2.31/3.09	N/A	.80-.91
20	N/A	.091/1.122	1.000	.150	.125	BR20L	S212	3.17	3.81	25.40	2.31/3.09	N/A	.80-.91
20-22	N/A	.042/0.73	1.000	.123	.075	BR20	S171	1.90	3.12	25.40	1.07/1.85	N/A	.65-.80
22	N/A	.061/.085	1.000	.125	.086	BR22T	S171	2.18	3.17	25.40	1.54/2.15	N/A	0.65
22	N/A	.054/.073	0.750	.117	.075	BR22	S171	1.90	2.97	19.05	1.37/1.85	N/A	0.65
22-24	N/A	.054/.073	1.000	.111	.075	BR224-1	S171	1.90	2.82	25.40	1.37/1.85	N/A	.50-.65
22-24	N/A	.054/.073	0.807	.111	.075	BR224	S171	1.90	2.82	20.50	1.37/1.85	N/A	.50-.65
24	N/A	.024/.043	1.000	.083	.044	BR2444*	S125LN*	1.11	2.10	25.40	0.60/1.09	N/A	0.50
24	N/A	.055/.074	1.500	.100	.075	BR24D	S159	1.90	2.54	38.10	1.39/1.87	N/A	0.50
24	N/A	.055/.074	0.750	.100	.075	BR24	S159	1.90	2.54	19.05	1.39/1.87	N/A	0.50
24-26	N/A	.058/.073	0.750	.100	.075	BR2426	S159	1.90	2.54	19.05	1.47/1.85	N/A	.40-.50
24-26	N/A	.054/.065	1.000	.098	.066	BR2466	S125LD	1.67	2.48	25.40	1.37/1.65	N/A	.40-.50
26	N/A	.054/.073	1.000	.112	.075	BR16903	S159	1.90	2.84	25.40	1.37/1.85	N/A	0.40
26	N/A	.023/.038	0.750	.068	.040	BR2639*	S93LN*	1.02	1.72	19.05	0.58/0.96	N/A	0.40
26	N/A	.058/.073	1.000	.100	.075	BR26	S159	1.90	2.54	25.40	1.47/1.85	N/A	0.40
30-32	N/A	.034/.038	0.750	.064	.040	BR30*	S93*	1.02	1.62	19.05	0.86/0.96	N/A	.20-.25

## Extended (5" Long) Bits and Sleeves Regular and Modified

22	N/A	.054/.073	0.750	.117	.075	BR22-5	S171-5	1.90	2.97	19.05	1.37/1.85	N/A	0.65
22-24	N/A	.054/.073	0.807	.111	.075	BR224-5	S171-5	1.90	2.82	20.50	1.37/1.85	N/A	.50-.65
24	N/A	.055/.073	0.750	.100	.075	BR24-5	S159-5	1.90	2.54	19.05	1.39/1.87	N/A	0.50
26	N/A	.058/.073	1.000	.100	.075	BR26-5	S159-5	1.90	2.54	25.40	1.47/1.85	N/A	0.40
26	.031	.023/.038	0.750	.075	.040	BM2640-5*	S93LN-5*	1.02	1.90	19.05	0.58/0.96	0.79	0.40
30	.027	.031/.035	0.750	.064	.036	BM30-5*	S93-5*	0.91	1.62	19.05	0.79/0.89	0.69	0.25

\* These tools are recommended for .025" square terminals on 0.100 centers / 0.63 mm on 2.54 mm centers.

### Insulated Sleeves

To order insulated sleeves, please specify insulation color on the end of the standard sleeve part number. (i.e. S171R: R=red, B=blue, Y=yellow, G=green, W=white).



JDV Products, Inc • 22-01 Raphael Street • Fair Lawn, NJ 07410 USA  
201-796-1720 • Fax 201-796-9399 • www.jdvproducts.com

# Hand Wrapping / Unwrapping Tools

**NEW!**



HWUR224

## New 22-24 AWG Hand Wrap/Unwrap Tool

The improved handle is made of high quality aluminum and is equipped with a longer 1.2 inch knurl throughout the grip area for ease of use. It's only 5.5 inches long when assembled and resists loosening during unwrap operation. See below for specifications.



### Wrap Side

## Regular Wrap Tools

### Unwrapping Side



Regular Wrap

**NEW!**

Part No	Wire Size		Max. Insulation Diameter		Terminal Hole Diameter		Terminal Hole Depth		Outside Diameter	
	AWG	mm	In.	mm	In.	mm	In.	mm	In.	mm
HWR18	18-19	1.00-0.91	-	-	.075	1.90	1.000	25.40	.250	6.35
HWR20	20	0.80	-	-	.075	1.90	1.000	25.40	.218	5.53
HWR22	22	0.65	-	-	.075	1.90	.750	19.05	.218	5.53
HWR224	22-24	0.50-0.65	-	-	.075	1.90	.807	20.50	.218	5.53
<b>HWUR224</b>	<b>22-24</b>	<b>0.50-0.65</b>	<b>-</b>	<b>-</b>	<b>.075</b>	<b>1.90</b>	<b>.807</b>	<b>20.50</b>	<b>.218</b>	<b>5.53</b>
HWR224-1	22-24	0.50-0.65	-	-	.075	1.90	1.000	25.40	.218	5.53
HWR224L	22-24	0.50-0.65	-	-	.086	2.18	1.000	25.40	.218	5.53
HWR24	24	0.50	-	-	.075	1.90	.750	19.05	.218	5.53
HWR24D	24	0.50	-	-	.075	1.90	1.50	38.10	.218	5.53
HWR2426	24-26	0.40-0.50	-	-	.075	1.90	.750	19.05	.218	5.53
HWR2444*	24	0.50	-	-	.044	1.11	1.000	25.40	.156	3.96
HWR26	26	0.40	-	-	.075	1.90	1.000	25.40	.218	5.53

Terminal Hole Diameter		Terminal Hole Depth		Outside Diameter	
In.	mm	In.	mm	In.	mm
.075	1.90	1.000	25.40	.187	4.74
.070	1.77	1.000	25.40	.156	3.96
.070	1.77	1.000	25.40	.156	3.96
.070	1.77	1.000	25.40	.156	3.96
<b>.070</b>	<b>1.77</b>	<b>1.000</b>	<b>25.40</b>	<b>.156</b>	<b>3.96</b>
.070	1.77	1.000	25.40	.156	3.96
.086	2.18	1.000	25.40	.156	3.96
.070	1.77	1.000	25.40	.156	3.96
.070	1.77	1.000	25.40	.156	3.96
.070	1.77	1.000	25.40	.156	3.96
.038	0.96	1.000	25.40	.093	2.36
.070	1.77	1.000	25.40	.156	3.96

### Wrap Side

## Modified Wrap Tools

### Unwrapping Side



Modified Wrap

Part No	Wire Size		Max. Insulation Diameter		Terminal Hole Diameter		Terminal Hole Depth		Outside Diameter	
	AWG	mm	In.	mm	In.	mm	In.	mm	In.	mm
HWM22	22	0.65	.052	1.32	.075	1.90	1.000	25.40	.218	5.53
HWM24	24	0.50	.046	1.17	.075	1.90	.750	19.05	.218	5.53
HWM24D	24	0.50	.050	1.27	.069	1.75	1.125	28.50	.218	5.53
HWM2444*	24	0.50	.044	1.11	.044	1.11	.750	19.05	.156	3.96
HWM26	26	0.40	.046	1.17	.075	1.90	1.000	25.40	.218	5.53
HWM2640*	26	0.40	.031	0.79	.040	1.02	.750	19.05	.125	3.17
HWM28	28	0.32	.030	0.76	.036	0.91	.750	19.05	.125	3.17
HWM2840*	28-29	0.29-0.32	.036	0.91	.040	1.02	.750	19.05	.156	3.96
HWM30*	30	0.25	.027	0.69	.036	0.91	.750	19.05	.125	3.17
HWM3066	30	0.25	.027	0.69	.066	1.67	1.000	25.40	.218	5.53

Terminal Hole Diameter		Terminal Hole Depth		Outside Diameter	
In.	mm	In.	mm	In.	mm
.070	1.77	1.00	25.40	.156	3.96
.070	1.77	1.00	25.40	.156	3.96
.070	1.77	1.00	25.40	.156	3.96
.038	0.96	1.00	25.40	.093	2.36
.070	1.77	1.00	25.40	.156	3.96
.038	0.96	1.00	25.40	.093	2.36
.038	.096	1.00	25.40	.093	2.36
.038	0.96	1.00	25.40	.093	2.36
.038	0.96	1.00	25.40	.093	2.36
.070	1.77	1.00	25.40	.156	3.96

\* These tools are recommended for .025" square terminals on 0.100 centers / 0.63 mm on 2.54 mm centers.



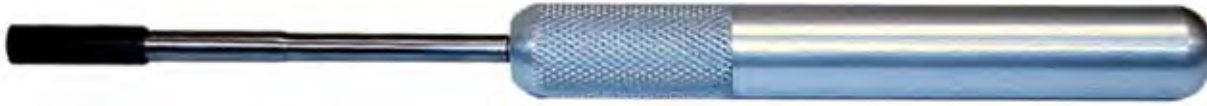

## Regular Wrap Tools

Part No	Wire Size		Max. Insulation Diameter		Terminal Hole Diameter		Terminal Hole Depth		Outside Diameter	
	AWG	mm	In.	mm	In.	mm	In.	mm	In.	mm
HR18	18-19	1.00-0.91	-	-	.075	1.90	1.000	25.40	.250	6.35
HR1920L	20	0.80	-	-	.125	3.17	1.000	25.40	.250	6.35
HR1920	20	0.80	-	-	.075	1.90	1.000	25.40	.218	5.53
HR22	22	0.65	-	-	.075	1.90	.750	25.40	.218	5.53
HR224	22-24	0.65-0.50	-	-	.075	1.90	.807	20.50	.218	5.53
HR224-1	22-24	0.65-0.50	-	-	.075	1.90	1.000	25.40	.218	5.53
HR224L	22-24	0.65-0.50	-	-	.086	2.18	1.000	25.40	.218	5.53
HR24	24	0.50	-	-	.075	1.90	.750	19.05	.218	5.53
HR24D	24	0.50	-	-	.075	1.90	1.500	38.10	.218	5.53
HR2444	24	0.50	-	-	.044	1.11	1.000	25.40	.156	3.96
HR2426	24-26	0.50-0.40	-	-	.075	1.90	.750	19.05	.218	5.53
HR26	26	0.40	-	-	.075	1.90	1.000	25.40	.218	5.53



## Modified Wrap Tools

Part No	Wire Size		Max. Insulation Diameter		Terminal Hole Diameter		Terminal Hole Depth		Outside Diameter	
	AWG	mm	In.	mm	In.	mm	In.	mm	In.	mm
HM20	20	0.80	.058	1.47	.075	1.90	1.000	25.40	.250	6.35
HM22	22	0.65	.052	1.32	.075	1.90	1.000	25.40	.218	5.53
HM24	24	0.50	.046	1.17	.075	1.90	.750	19.05	.218	5.53
HM24D*	24	0.50	.050	1.27	.069	1.75	1.125	28.50	.218	5.53
HM2444*	24	0.50	.044	1.11	.044	1.11	.750	19.05	.156	3.96
HM2426	24-26	0.50-0.40	.046	1.17	.075	1.90	.750	19.05	.218	5.53
HM26	26	0.40	.046	1.17	.075	1.90	1.000	25.40	.218	5.53
HM2640*	26	0.40	.031	0.79	.040	1.02	.750	19.05	.125	3.17
HM2669	26	0.40	.041	1.04	.069	1.75	1.000	25.40	.218	5.53
HM2840*	28-29	0.32-0.29	.036	0.91	.040	1.02	.750	19.05	.156	3.96
HM30	30	0.25	.027	0.69	.036	0.91	.750	19.05	.125	3.17
HM30SP*	30	0.25	.027	0.69	.036	0.91	.750	19.05	.125	3.17
HM3066	30	0.25	.027	0.69	.066	1.67	1.000	25.40	.218	5.53
HM3040*	30	0.25	.027	0.69	.040	1.02	.750	19.05	.125	3.17
HM3043*	30	0.25	.027	0.69	.043	1.09	.750	19.05	.125	3.17



\* These tools are recommended for .025" square terminals on 0.100 centers / 0.63 mm on 2.54 mm centers.



# Wrap/Strip/Unwrap Tools

**Three tools in one!** With a compact design, these economic tools can wrap, strip, and unwrap wire with ease! Perfect for small repair, service work, and for any hobbyist.



Part No.	Wire Size		Terminal Hole Dia.		Terminal Hole Depth		Outside Diameter		Wrap Type
	AWG	mm	In.	mm	In.	mm	In.	mm	
HSR224	22-24	0.65-0.50	0.075	1.90	1.50	38.1	0.213	5.40	Reg
HSR30	30	0.25	0.036	0.91	1.50	38.1	0.125	3.18	Reg
HSM30	30	0.25	0.075	0.91	1.50	38.1	0.125	3.18	Mod

## Micro Hand Wrap/Strip Tool

This unique tool is designed for regular or modified 30 AWG wire wraps, respectively on .025 in square terminals. Features a nickel-plated brass knurled handle with a storage cavity for the wire stripper, manually tightened collet for easy bit replacement and swivel end cap for effortless turning.



Wire Stripper in Handle

Part No.	Wire Size		Terminal Hole Dia.		Terminal Hole Depth		Wrap Type
	AWG	mm	In.	mm	In.	mm	
MT30R	30	0.025	0.040	1.02	0.75	19.05	Reg
MT30M	30	0.025	0.036	0.91	0.75	19.05	Mod

## Hand Unwrapping Tools

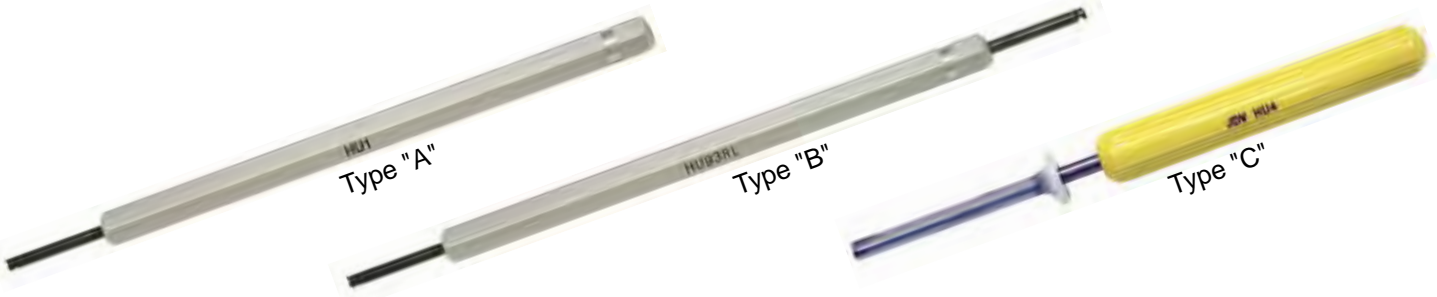

Part No.	Type	Wire Size		Direction of Wrap		Terminal Hole Diameter		Terminal Hole Depth		Outside Diameter	
		AWG	mm	CCW ↺ (L)	CW ↻ (R)	In.	mm	In.	mm	In.	mm
HU75	A	18-19	1.00-0.91	*		.075	1.90	1.000	25.40	0.187	4.74
HU1	A	20-26	0.80-0.40	*		.070	1.77	1.000	25.40	0.156	3.96
HU2	B	20-26	0.80-0.40	*	*	.070	1.77	1.000	25.40	0.156	3.96
HU4	C	20-26	0.80-0.40	*		.070	1.77	2.360	60.00	0.187	4.74
HU5	C	20-26	0.80-0.40	*	*	.070	1.77	2.360	60.00	0.187	4.74
HU7	A	20-26	0.80-0.40	*		.086	2.18	0.750	19.05	0.156	3.96
HU8	A	20-26	0.80-0.40	*		.070	1.77	1.500	38.10	0.120	3.04
HU120	A	20-26	0.80-0.40	*		.070	1.77	1.000	25.40	0.120	3.04
HU120RL	B	20-26	0.80-0.40	*	*	.070	1.77	1.000	25.40	1.120	3.04
HU93120	B	24-32	0.50-0.20	*		.038	0.96	1.000	25.40	0.093	2.36
		20-26	0.80-0.40	*		.070	1.77	1.000	25.40	0.120	3.04
HU93	A	24-32	0.50-0.20	*		.038	0.96	1.000	25.40	0.093	2.36
HU93L	A	24-32	0.50-0.20		*	.038	0.96	1.000	25.40	0.093	2.36
HU93RL	B	24-32	0.50-0.20	*	*	.038	0.96	1.000	25.40	0.093	2.36
HU3	C	28-32	0.32-0.20	*	*	.038	0.96	0.750	19.05	0.156	3.96
HU45	A	20-26	0.80-0.40	*		.045	1.14	1.000	25.40	0.120	3.04



# Semi-Automatic Wire Wrapping Systems



## Complete System Consists of:

- 1.) X-Y Wiring Table (see chart)
- 2.) Controller System, consisting of:
  - Controller
  - Manual
  - Software
  - Power Cable
  - Interface Cable
  - "Y" Connector
- 3.) Computer System
  - PC
  - Monitor
  - Keyboard & Mouse
- 4.) 40 Tube Wire Storage Bin
- 5.) Lift Base (Models SW3100 and SWT-3100 ONLY)

\* For a demonstration video, please visit our website

The SW-1100, SW-2100, and SW-3100 Semi-Automatic Wire Wrapping Systems are designed to significantly speed up the wire wrapping process by pointing the operator's wire wrap tool to the correct pins. This gives the operator step-by-step instruction through on-screen prompts, thus guiding the operator through the entire wire wrapping process.

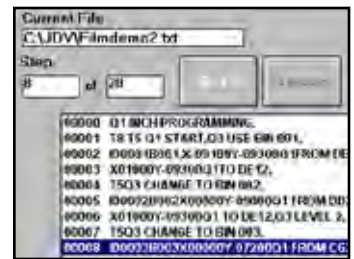
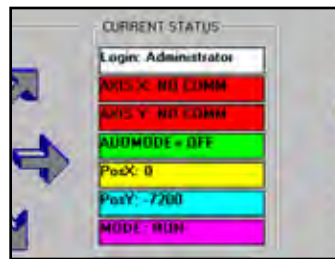
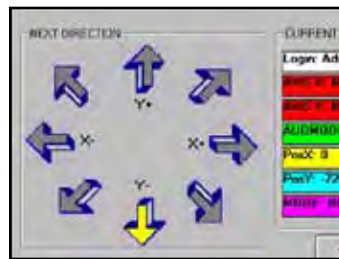
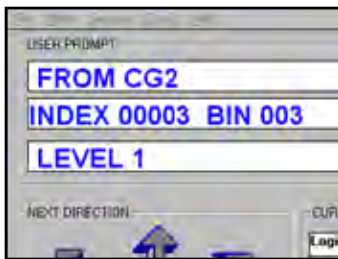

The result is a ten-fold increase in production rate and the potential for significant reduction in technician error over manual wire wrapping. The systems are designed for ease-of-use, and are significantly more cost-effective than fully-automatic systems.

The newly designed Rapid Wrap System Controller incorporates many new features/benefits including:

- Parts programming in industry-proven ASCII format.
- User selectable units of measure
- Very simple Windows® user interface.
- Maintains a time-stamped text log file of activities such as:
  - Starting and finishing a job
  - Last position (in case of power failures)
  - User and supervisor logins/logouts
- Easily networkable through Windows® networking
- Prompts the operator with wire bin numbers
- Reduces potential for human error



Complete Systems	
<b>SW1100</b>	Complete System with 20" x 20" X-Y Table
<b>SW2100</b>	Complete System with 40" x 30" X-Y Table
<b>SW3100</b>	Complete System with 40" x 30" X-Y Table and Lift Base

Part No.	Tables			Computer System SWS-2000	Controller w/ Software SWC-2000	Wire Bin SWB-40
	SWT1100	SWT2100	SWT3100			
SW1100	•			•	•	•
SW2100		•		•	•	•
SW3100			•	•	•	•

System Components	
<b>SWB40</b>	40 Tube Wire Storage Bin
<b>SWC2000</b>	Controller System with Software
<b>SWS2000</b>	Computer System
<b>SWT1100</b>	X-Y Table 20" x 20" Wire Area
<b>SWT2100</b>	X-Y Table 40" x 30" Wire Area
<b>SWT3100</b>	X-Y Table 40" x 30" with Electric Lift Base
<b>SWRCC</b>	Retrofit Connector Cable Assembly
<b>SWLB115</b>	Electric Lift Base, 115 Volts
<b>SWLB230</b>	Electric Lift Base, 230 Volts



# Wire

## Wire Rolls

- Kynar™ insulated wire
- Silver plated copper wire conductor
- UL listed
- Additional colors, gauges, and larger roll sizes up to 20,000 feet are special order only. Call for details.



Wire		Insulation DIA		Roll Size		Part No.				
AWG	mm	Inch	mm	ft.	m	White	Yellow	Blue	Red	Black
24	0.50	0.030	0.76	500	152	WR24W-D	WR24Y-D	WR24B-D	WR24R-D	WR24BL-D
				1000	304	WR24W-M	WR24Y-M	WR24B-M	WR24R-M	WR24BL-M
26	0.40	.027	0.69	500	152	WR26W-D	WR26Y-D	WR26B-D	WR26R-D	WR26BL-D
				1000	304	WR26W-M	WR26Y-M	WR26B-M	WR26R-M	WR26BL-M
28	0.32	.024	0.60	500	152	WR28W-D	WR28Y-D	WR28B-D	WR28R-D	WR28BL-D
				1000	304	WR28W-M	WR28Y-M	WR28B-M	WR28R-M	WR28BL-M
30	0.25	.0195	0.50	500	152	WR30W-D	WR30Y-D	WR30B-D	WR30R-D	WR30BL-D
				1000	304	WR30W-M	WR30Y-M	WR30B-M	WR30R-M	WR30BL-M

## Pre-Cut & Stripped Wire

- 1" (25.4mm) strip-off length (both ends)
- Kynar™ insulated
- Silver plated copper conductor
- 0.0195" (0.50mm) Insulation diameter
- UL listed

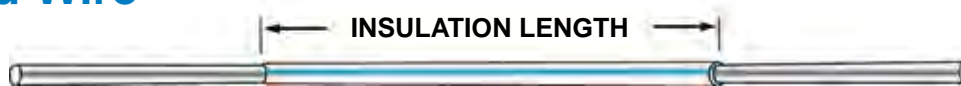

Insulation Length		Part No. (500 Piece Pack)				
In	mm	White	Yellow	Blue	Red	Black
1	25	W30W010	W30Y010	W30B010	W30R010	W30BL010
1.5	38	W30W015	W30Y015	W30B015	W30R015	W30BL015
2	51	W30W020	W30Y020	W30B020	W30R020	W30BL020
2.5	63	W30W025	W30Y025	W30B025	W30R025	W30BL025
3	76	W30W030	W30Y030	W30B030	W30R030	W30BL030
3.5	89	W30W035	W30Y035	W30B035	W30R035	W30BL035
4	101	W30W040	W30Y040	W30B040	W30R040	W30BL040
4.5	114	W30W045	W30Y045	W30B045	W30R045	W30BL045
5	127	W30W050	W30Y050	W30B050	W30R050	W30BL050
6	152	W30W060	W30Y060	W30B060	W30R060	W30BL060
7	178	W30W070	W30Y070	W30B070	W30R070	W30BL070
8	203	W30W080	W30Y080	W30B080	W30R080	W30BL080
9	228	W30W090	W30Y090	W30B090	W30R090	W30BL090
10	254	W30W100	W30Y100	W30B100	W30R100	W30BL100

## Wrap ID Tags

These tags are used to identify pin numbers on wrapping sockets. Consisting of a socket-sized plastic panel with numbered holes in the pin location, the ID tag is slipped onto the socket before wrapping. They can also be written on for easy identification of location, IC part number, function, etc. These unique items greatly simplify both initial wire wrapping and subsequent troubleshooting or repair. A great help to technicians and production facilities alike.



Part No.	Pins	Row Spacing		Qty/ Pkg.	Part No.	Pins	Row Spacing		Qty/ Pkg.
		Inch	mm				Inch	mm	
ID8	8	0.3	7.5	100	ID24-3	24	0.3	7.5	50
ID14	14	0.3	7.5	100	ID24-4	24	0.4	10	50
ID16	16	0.3	7.5	100	ID24	24	0.6	15	50
ID18	18	0.3	7.5	50	ID28	28	0.6	15	25
ID20	20	0.3	7.5	50	ID40	40	0.6	15	25
ID22	22	0.4	10	50	ID96	96	0.3	7.5	25



## LED Flashlight Bracket Assy.

The New FL100 is the perfect tool to illuminate the working area while making wire wrap connections. It's equipped with a high-density LED light providing operators with 15 hours of consecutive illumination when needed. With a simple flick of a switch, the beam of the light can be easily adjusted to intersect with the tips of 3" and 5" wrapping bits. Easily mounts on top of JDV's aluminum or Lexan® manual wire wrap tools as well as most competitor's models.

Part No	Description
FL100	LED Flashlight Bracket Assy
FL-LED	Replacement LED Light
FL-BKT	Replacement Bracket w/Hardware
FL-BT	Replacement Batteries, Set of 2pcs



Shown with NEW Insulated WG800 model wrap tool

\* For more information on manual wire wrapping tools, please see page 4

**NEW & IMPROVED DESIGN**



TH251R

**Left-Handed Now Available!**



TH251L

## Deep Cavity Tool Pouch

The New TH251's deeper cavity gives the room needed for storing the wrapping gun with the bit/sleeve still attached to the tool.

Great for carrying any JDV manual, battery, or electric operated wrapping guns along with accessory tools such as wrapping bits/sleeves, hand wrap/unwrap tools, and cut/strip tools.

Part No	Type	Description
TH251R	Right-Handed	Nylon Wire Wrap Holster
TH251L	Left-Handed	Nylon Wire Wrap Holster

\* For Wire Wrap Tool Kits, please see page 16

## Spare Part Kits for Manual Wire Wrap & Unwrap Tools

Spare Part Repair Kits for these Wire Wrap Guns



WG100R3278INS-S  
Aluminum

WG200-R3278  
Lexan®

WG100R3394INS  
Aluminum (Unwrap)



### KIT-A

For Aluminum and Lexan® models

**Includes**

- Spindle (Barrel Assembly)
- Large Gear Assembly
- Small Packet of Grease



### KIT-B - For Aluminum models

**KIT-C - For Lexan® models**

**Includes**

- Spindle (Barrel Assembly)
- Large Gear Assembly
- Small Packet of Grease
- 2 Coil Springs
- Screws
- Rubber Stops



# Wire Wrap Tool Kits

These telecom wire wrap tool kits are designed to provide field service with a complete line of tools to perform regular wraps, unwrap, and strip wires in two wire gauge sets: 22 and 24 AWG or 24 and 26 AWG.

Follow the three easy steps to customize your preferred kit:

## STEP 1



## STEP 2



## WIRE WRAP KIT

Begin with a Starter kit

Select a Wire Wrap Tool of your choice

Now that you know which wrap gun you prefer, the last step is to choose the kit part number for your application: 22-24 AWG or 24-26 AWG?



Starter Kit includes all of the essential tools you need for making wire wrap connections for 22-24 AWG or 24-26 AWG applications.

- |                        |                        |
|------------------------|------------------------|
| <b>22-24 AWG Kits:</b> | <b>24-26 AWG Kits:</b> |
| • TH251R               | • TH251R               |
| • BR224 / S171R        | • BR2426 / S159Y       |
| • HR224                | • HR2426               |
| • HU4                  | • HU4                  |
| • WS100-224            | • WS100-2426           |



**WG800  
INSULATED  
Manual Wrap Tool**

Part No.	Description
<b>KTW800-224</b>	Kit w/ Manually Operated <b>INSULATED</b> Wrap Tool 22-24 AWG
<b>KTW800-2426</b>	Kit w/ Manually Operated <b>INSULATED</b> Wrap Tool 24-26 AWG



**WG200  
Manual Wrap Tool**

Part No.	Description
<b>KTW200-224</b>	Kit w/ Manually Operated Lexan® Wrap Tool 22-24 AWG
<b>KTW200-2426</b>	Manually Operated Lexan® Wrap Tool 24-26 AWG



**WG601  
Electric Wrap Tool**

Part No.	Description
<b>KTW601-224</b>	Kit w/ 120V AC Operated Wrap Tool 22-24 AWG
<b>KTW601-2426</b>	Kit w/ 120V AC Operated Wrap Tool 24-26 AWG



**WG500  
Battery  
Wrap/Unwrap Tool**  
(Tool, Charger, 1 Battery)

Part No.	Description
<b>KTW500-224</b>	Kit w/ Battery Operated Wrap/Unwrap Tool 22-24 AWG
<b>KTW500-2426</b>	Kit w/ Battery Operated Wrap/Unwrap Tool 24-26 AWG



# Punch Down Tool, Wrenches, Accessories

## Punch Down Tool

JDV's PD207 punch down tool inserts and cuts cable terminations effortlessly. The impact absorbing cushioned grip reduces operator stress for high volume installers. The adjustable high/low actuation setting accommodates termination requirements as well as operator preference. It's equipped with a storage compartment for spare blades for preventing blade loss.

(Replacement blades sold separately)

Part No.	Description
PD207	Punch Down Tool (no blade)
PD207-A	Replacement Blade, Use on 66 Type Terminal Block
PD207-B	Replacement Blade, Use on 110/88 Type Terminal Block



Blades are conveniently stored in the handle



## Double-End Hex Can Wrench

JDV's CW737 can wrench features a 3/8" black finish and 7/16" silver finish hex end for opening telecommunication cabinets, pedestals, placing fuses in cable terminals, connecting wires to fuses, and for tightening nuts on binding post terminals. The walls on both sockets are thin enough so it can be used to work locking devices on most terminals and cabinets. Handle is made of high quality plastic and has a 7 inch overall length.

## JDV "C" Regulator Wrench

The YC1116 "C" Regulator Wrench is used for cylinder and hose connection nuts on pressure testing regulators and for the hex nuts on gas manifolds and cylinder connectors.

The openings accommodate nut widths of 11/16", 1-1/8", and 1-3/16".



## Wire Cutter / Stripper

JDV's WS208 strips and cuts wire from 10-20 AWG (4-0.5 mm). Designed with PVC handle grips for comfort, a spring return mechanism to open position, and is only 5 inches in length.



# Wire Strippers



## 3000 Series

- Excellent tool for stripping vinyl insulation
- Perfect and quick stripping of insulation in one operation
- Provides the Ideal Cleaning Surface
- Ergonomically designed plastic grip
- 6 styles according to wire diameter



Part No.	Length (mm)	Weight (g)	Wire Core Diameters/Square	Handle Color
3000A	170	350	0.5/1.2/1.6/2.0mm (solid wire)	Green
3000B	170	350	1.0/1.6/2.0/2.6/3.2mm (solid wire)	Red
3000C	170	350	0.9/1.25/2.0/3.5/5.5mm <sup>2</sup> (for strand wire)	Black
3000D	170	350	0.75mm <sup>2</sup> x2 cores/1.25mm <sup>2</sup> x <sup>2</sup> cores (for flat vinyl wire)	Orange
3000G	170	350	3.8mm/5.6mm/core line (coaxial cable wire 3C2V, 5C2V)	Dk. Blue
3000VA	170	350	1.6mm x2 cores/2.0mm x <sup>2</sup> (VAIV wire)	Blue



## Replacement Blades



## 3500E-1

- Lightweight (100g)
- Diamond polished blade for precision stripping
- AWG-mm-mm<sup>2</sup> conversion table on grip
- Locking lever
- Wire core sizes:
  - 24 AWG
  - 22 AWG
  - 20 AWG
  - 18 AWG
  - 16 AWG
  - 14 AWG
  - 12 AWG



## 3500E-2

- Lightweight (100g)
- Diamond polished blade for precision stripping
- AWG-mm-mm<sup>2</sup> conversion table on grip
- Locking lever
- Wire core sizes:
  - 30 AWG
  - 28 AWG
  - 26 AWG
  - 24 AWG
  - 22 AWG
  - 20 AWG
  - 18 AWG



## WS100 Series

Part No.	Wire Size		Adjustable Strip-off Length	
	AWG	mm	In.	mm
WS100-22	22	0.65	1-5/16" to 1-9/16"	33.33 to 39.68
WS100-224	22-24	0.65-0.50	1-5/16" to 1-9/16"	33.33 to 39.68
WS100-24	24	0.50	1-5/16" to 1-9/16"	33.33 to 39.68
WS100-2426	24-26	0.50-0.40	1-5/16" to 1-11/16"	33.33 to 42.86
WS100-26	26	0.40	1-5/16" to 1-11/16"	33.33 to 42.86
WS100-28	28	0.32	7/8" to 1-1/8"	22.22 to 28.57
WS100-30	30	0.25	7/8" to 1-1/8"	22.22 to 28.57



A compact and simple tool for easy and clean stripping of wires for wire wrapping, as well as electronic and appliance applications. This tool is designed for maximum efficiency. Easy to operate... place wire (up to 4) in stripping slot with ends extending beyond cutter blades... press tool and pull... wire is cut and stripped to proper "wire wrapping" length. The hardened steel cutting blades and sturdy construction of the tool ensure long life. Strip length is easily adjustable for your application.

## WS3907 Series

Part No.	Wire Size		Adjustable Strip-off Length	
	AWG	mm	In.	mm
WS3907-22	22	0.65	1-1/2" to 1-3/4"	38.10 to 44.45
WS3907-224	22-24	0.65-0.50	1-1/2" to 1-3/4"	38.10 to 44.45
WS3907-24	24	0.50	1-1/2" to 1-3/4"	38.10 to 44.45
WS3907-2426	24-26	0.50-0.40	1-1/2" to 1-3/4"	38.10 to 44.45
WS3907-26	26	0.40	1-1/2" to 1-3/4"	38.10 to 44.45
WS3907-28	28	0.32	7/8" to 1-1/8"	22.22 to 28.57
WS3907-30	30	0.25	7/8" to 1-1/8"	22.22 to 28.57



For applications requiring multiple cuts and strips of the same gauge wire, the WS3907 is the most effective tool. Easy to operate... place the wires in stripping slot with ends extending beyond cutter blades... press tool and pull... wire is cut and stripped to proper "wire wrapping" length. The plastic grips and soft rubber sleeve assures maximum handling comfort and slip-free gripping.

## WS4473 Series

Part No.	Wire Size		Adjustable Strip-off Length	
	AWG	mm	In.	mm
WS4473	2-24	0.65-0.50	7/8"	22.2
	24-26	0.50-0.40		
WS4473C	22-24	0.65-0.50	to	to
	24-26	0.50-0.40		
	28	0.32	2"	55.8
	30	0.25		



When combinations of wire gauges and longer strip-off lengths are required, the WS4473 should be selected. Two models are available: the WS4473 is furnished with combination blades for 22-26 AWG wire, and the WS4473C is furnished with combination blades for 22-30 AWG wire. Blades are easily interchangeable on the blade post. This tool is furnished with rust-resistant, oiled, black oxide coating and soft sponge-like grips.

## WS200 Series "The Gatling"

Part No.	Wire Size		Adjustable Strip-off Length	
	AWG	mm	In.	mm
WS201	22	0.65	1-1/8"	28.6
	24	0.50	to	to
	26	0.40	2"	50.8
WS202	26	0.40	7/8"	22.2
	28	0.32	to	to
	30	0.25	1-7/8"	28.6



The "Gatling" hits all the targets! This is the latest innovative tool from JDV Products. Two models are available, each with a tripple stripper (3 wire gaps) in one tool. The WS201 will cut and strip 22, 24, and 26 AWG wire with no blade change required. The WS202 will cut and strip 26, 28, and 30 AWG wire with no blade change. Each tool is equipped with an easy to use dial mechanism that will move the blade along the blade post to vary the shiner (strip-off) length.

Replacement blades are available for each model. Please call JDV for details



JDV Products, Inc • 22-01 Raphael Street • Fair Lawn, NJ 07410 USA  
201-796-1720 • Fax 201-796-9399 • www.jdvproducts.com

# Fiber Optic Patchcords

## OPTICAL FIBER PATCH CORDS & CONNECTORS

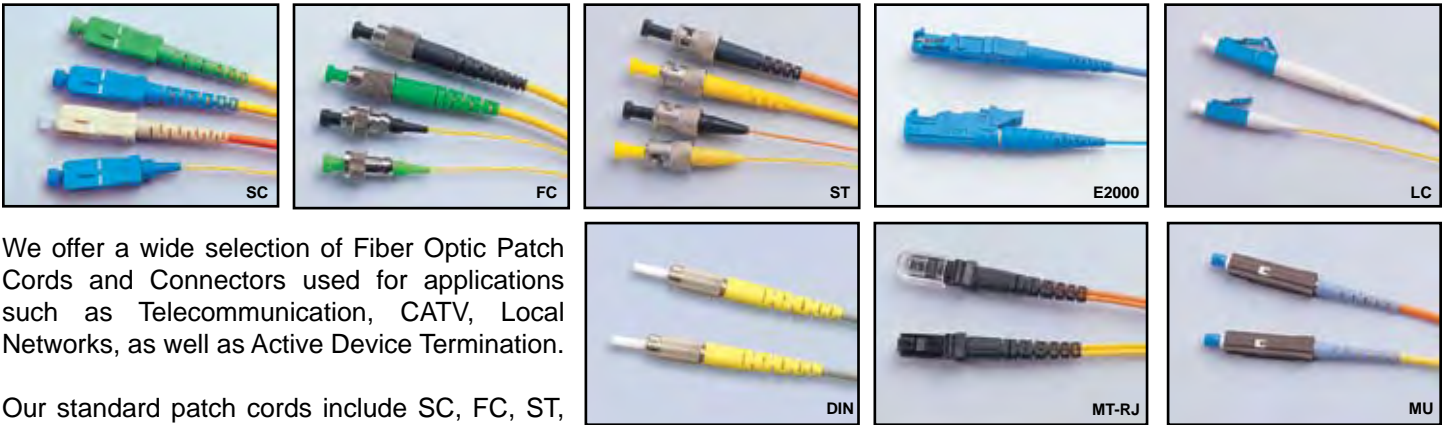

We offer a wide selection of Fiber Optic Patch Cords and Connectors used for applications such as Telecommunication, CATV, Local Networks, as well as Active Device Termination.

Our standard patch cords include SC, FC, ST, and LC type connectors with factory tested 100% optical performance. These items have precision ceramic ferrules with endface and are compliant with JIS C-5973, IEC, and Bellcore.

If needed, JDV can supply special models including E2000, DIN, MU, MT-RJ, and MPO. Customized assemblies are available which include lengths, connector style, and performance.

For specifications or ordering information, please contact JDV.

Characteristics	Conditions	Values
<b>Insertion Loss</b>	Against Reference Connector	<0.1dB, <0.2dB
<b>Return Loss</b>	UPC	>55dB
<b>Durability</b>	APC	>65dB
<b>Temperature Cycling</b>	5000 Times	<0.2dB
<b>Humidity Cycling</b>	-40~+80°C (21 Cycles), 168hr	<0.2dB
<b>Vibration</b>	-10~+65°C, 95%RH, 168hr	<0.2dB
<b>Flex Test</b>	20G, 20~2000Hz, 4min/Cy, axis, 6 axis	<0.2dB
<b>Twist Test</b>	0° ->90° ->0° -> 90°, 5Kgf (100 cycles)	<0.2dB
<b>Straight Pull Test</b>	100N Load, 5 sec at least	<0.2dB
<b>Impact</b>	5 Times/Direction, 6 Direction, 500G, 1ms	<0.2dB

### Fiber Connector Insertion & Removal Tool

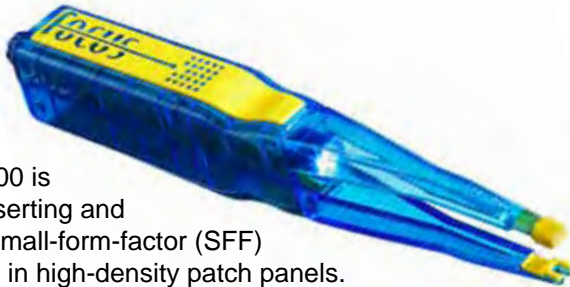

The PCR100 is ideal for inserting and removing small-form-factor (SFF) connectors in high-density patch panels. Works with SC, SC2, MU, LC, and MTRJ connectors and different cables, including 2mm, 3mm, 1.6mm, jacketed, and 900um buffered cables.

This ergonomically designed tool is equipped with a spring-loaded handle, non-conducting material, and can be used inside or outside environments with an operating temperature of -40°C to +95°C.

Specifications:	
<b>Tool Weight *</b>	5.9 oz/ 167 grams
<b>Tool Length</b>	8.436 in / 214.2 mm
<b>Tool Width</b>	1.170 in / 28.7 mm
<b>Tip Width</b>	0.309 in / 7.8 mm
<i>* Weight includes installed flashlight</i>	

Equipped with a removable flashlight for illuminating ports and connectors in low-light environments.

Replaceable flashlight Part No. PCRL100

Long, narrow jaws reach back of patch panel enclosures with ease. Jaws are spring-loaded and will not lock onto the connector; which prevents damage to connector and cable.

Universal tips are made of special material in order to provide firm grasp on small form-factor connectors.



## How to Clean Fiber Optic Connections using the Combination Cleaning Method



1. Spray a minimal amount of Electro-Wash on wipe
2. Press fiber optic surface to wipe, and pull across the surface
3. Check your work with a fiber scope or other equipment
4. Each section of wipe can be used a multiple of times without using the same surface twice.

## Fiber Optic Cleaning

### Specifications:

- A complete Fiber Optic Cleaning System with no costly refills or investments in expensive mechanisms to maintain
- The combination cleaning method by choice! Delivers effective "wet" and "dry" connector cleaning
- Provides the Ideal Cleaning Surface
- Portable cleaning system easily fits in tool cases or stores on work benches
- A Heavy-Duty Lint-Free Wiping Material tough enough to remove buffer-gel, yet soft enough for all end-face cleaning
- Won't shred or tear

### Applications:

- End-face connector cleaning
- Splice preparation
- Buffer gel removal



ES1210



48042F



38542F



51125F



Precision cleaning swabs specifically designed to clean micro-contamination encountered in fiber optic telecommunications. From removing end-face contamination on a fiber optic connector, to cleaning contamination from your fusion splicer, these ultra-clean swabs will make clear, clean and safe connections, fast and easy. These swabs keep contamination out of your processes, and perform consistently.

25125F



Part No.	Description
QbE	Wipes for Open End Faces, 200 per box
QbE-R	Wipes for Recessed Faces, 200 per box
25125F	1.25mm Open End Face Cleaning Swab, 15 per tube
48042F	2.5mm Fiber Optic Foam Swab, 50 Swabs per tube
38542F	V-Groove & Ceramic Ferrule Cleaning Swab, 50 per tube
51125F	Fusion Splice Mirror Cleaning Swab, 15 per tube
ES1210	Electro Wash, 5 oz can

Complete Cleaning Kits also available. Please call JDV for details.



JDV Products, Inc • 22-01 Raphael Street • Fair Lawn, NJ 07410 USA  
201-796-1720 • Fax 201-796-9399 • www.jdvproducts.com

# Fiber Optic Cleavers

## **NEW!** SMART CLEAVER

### Single Action Cleavers

These units are small and compact and are perfect for making high precision preparation of single and ribbon fiber cables.

Most conventional fiber cleavers in the marketplaces are manual type cleavers, which require multiple steps in order to cleave the fibers, until now. The JDV *SMART Cleavers* (models SC-03 & SC-02) only require **ONE single action** to cleave the fibers after loading.

Our model SC-03B is a single fiber cleaver, and model SC-03M is a ribbon fiber cleaver for up to 12-ribbon fiber counts. Both models include a waste fiber collector for safe disposal of scrap fibers as well as a built-in maintenance tool attachment.

### Multi Action Cleavers

Manual (multi-action) cleavers available and are fully applicable for high preparation for single fibers and 12-ribbon fiber counts. Model SC-01B equipped with fiber collector and SC-01A is normal version without fiber collector. Equipped with compact design, scratch-free anodized body surface, and a built-in maintenance tool attachment.



SC-03B  
(Single Fiber)

**SINGLE-ACTION CLEAVE!**

**Fiber Loading**

SC-03M  
(Ribbon Fiber)

↓

**Operation Complete!**

Part No.	Description
SC-03B	Single-Action Cleaver for Single Fiber, w/Fiber Collector
SC-03M	Single-Action Cleaver for Ribbon Fiber, w/Fiber Collector
SC-02	Single-Action Cleaver for Single and Ribbon Fiber, No Fiber Collector
SC-01A	Multi-Action Cleaver for Single and Ribbon Fiber, No Fiber Collector
SC-01B	Multi-Action Cleaver for Single and Ribbon Fiber, w/Fiber Collector
Accessories	
SCB-05	Replacement Cleave Blade (SC-01 & SC-02)
SCG-01	Gauge for SC-01 & SC-02 Series Cleavers

### TECHNICAL PARAMETERS & SPECIFICATIONS

	Cleave Series		
	SC-03	SC-02	SC-01
Fiber Diameter	125 um	125 um	125 um
Coating Diameter	250~900 um	250~900 um	250~900 um
Cleave Angle	90° +/- 0.5°	0.5°	90° +/- 0.5°
Cleave Length	B: 5~20mm, M: 10mm	B: 5~20mm, M: 10mm	A/B: 5~20mm, M: 10mm
Blade Lifetime	48,000 Fibers	48,000 Fibers	48,000 Fibers
Outfit Dimension	88 x 55 x 48 (mm)	84 x 65 x 54 (mm)	58 x 55 x 48 (mm)
Weight	360 (g)	470 (g)	360 (g)



JDV Products, Inc • 22-01 Raphael Street • Fair Lawn, NJ 07410 USA  
201-796-1720 • Fax 201-796-9399 • www.jdvproducts.com

# Fiber Optic Strippers & Cutting Shears

## Shears for Fiber Optics

Three tools in one! The FS216 strips 125 micron glass fibers with 250 micron buffer coating without scratching or nicking the glass fiber. Equipped with a lock, stopper, spring-loaded handle, and is 5.9" (150mm) in length.

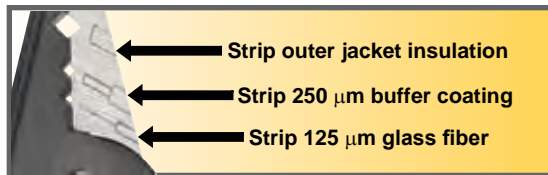

**A Hi-Leverage Kevlar snip** with 6 1/2" of ergonomic cutting action! Featuring an automatic return spring, special design blades, cushion grip handles, and a top blade with precision serrated cutting edges. This is the ideal snip for trimming back the Dupont Kevlar® that serves as the shield in optical fiber.

*Kevlar is a registered trademark of Dupont*

**SF743**



The most widely used tool in the communication market. The SF100CDS has a chrome over nickel plating and wire stripping notches for 19 and 23 AWG wire. The bottom blade has deep serrations the full length of the cutting edge. A file and scraper are featured on the back of the blades, making this tool also excellent for cleaning wire.

**SF100CDS**

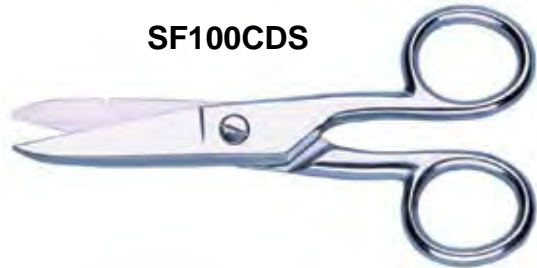

## Shears for Copper Cable

**SC152S**



### Stainless Cable Splicer Snip

**Tired of rusty tools?** Do your hands get irritated from plating issues? This hot-forged ice-tempered stainless Electrician Snip resolves both these issues. The SC152S is made from 420 Stainless steel with a Rockwell of 57 for long-lasting cutting edges.

Perfect for Telecom! This Free-Running style snip is ergonomically designed for a cleaner, quicker, and effortless cut; minimizing fatigue and strain on the wrist. The large ring has a soft blue coated handle that nests in the palm of your hand and stripping notches for 19 & 23 AWG wire. One blade is fully serrated for Sure-Grip cutting action. High-carbon steel, nickel plated.

**SC149**



**SC100J**



The unique protruding tip allows crews to cut open jackets on telecom cables in a safe and efficient manner. The knife doubles in function as an installation and repair crew wire splicing and skinning knife. Hot-forged nickel-plated, Rockwell 57 on the "C" scale. Handle is coated with blue non-slip surface. Industrial finish.



# Cable Preparation Tools

## Cable Stripper



JDV's CSDT-6590 drop stripping tool ensures quality connections and satisfied customers every time. Lightweight and yet rugged enough for the toughest jobs, these tools are virtually indestructible.

Works on 6-, 59-, 7-, and 11- series cables with both standard and quad shields and is equipped with high quality tool-steel blades for long life, clean-out feature for removing debris with each use, and replacement cartridges that snap into place.

With ease, the CSDT-6590 removes the right amount of cable jacket, cut the braid and dielectric to the proper length and expose the center conductor. Quality steel blades ensure 2500~5000\* preparations with each cartridge.

(\* Number of preparations depends on braid coverage.)

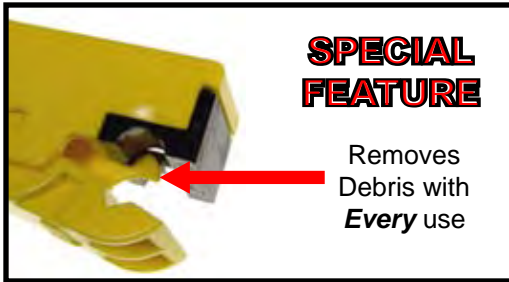

### SPECIAL FEATURE





Removes Debris with **Every** use

## Cable Stripper

The CSTS3 and CSTS5 coax cable strippers are perfect economy tools for stripping 3C-2V and 5C-2V/5C-FB applications.

Features include a compact and lightweight body, high quality cutting blades, spring loaded, locking mechanism for safety when not in use, and only weighs 50 grams.

### Easy Operation!

-  Step #1: Cut coaxial cable end
-  Step #2: Remove outside cable jacket
-  Step #3: Strip braided shield
-  Step #4: Cut dielectric material

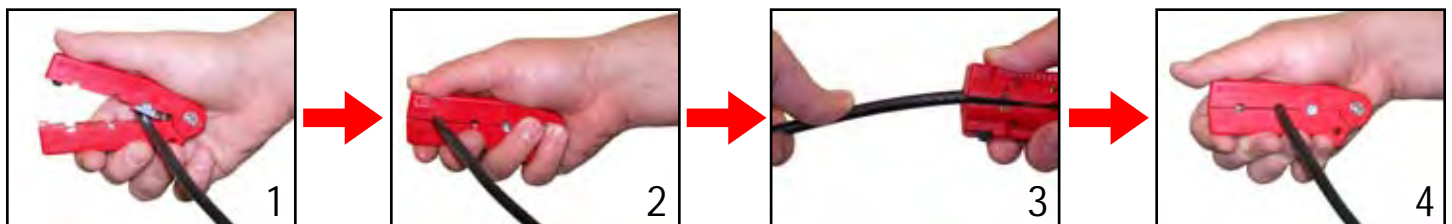

JDV Products, Inc • 22-01 Raphael Street • Fair Lawn, NJ 07410 USA  
201-796-1720 • Fax 201-796-9399 • www.jdvproducts.com

# Cable Preparation Tools

## Cable Stripper

The CSMK02 is designed for stripping outer jackets and PE, PVC, or rubber insulations on cables from 3/16" to 1-1/8" (4.5mm to 28.5mm) O.D. with an insulation depth of up to 1/8" (3mm) maximum. It's wide stripping range is applicable with most cables.

- Circumferential and longitudinal stripping action
- Adjustable cutting depth up to 1/8" (3mm)
- Durable construction for rugged applications
- Lightweight and compact

Dimensions:

Length: 5.26 in (135mm)

Height: 1.56 in (40mm)

Width: 0.585 in (15mm)

Weight: 4.2 ounces (120g)

Replacement blades sold separately:

Spherical Cutting Blade: Part No. RBMK02S

Chisel Point Blade: Part No. RBMK02C

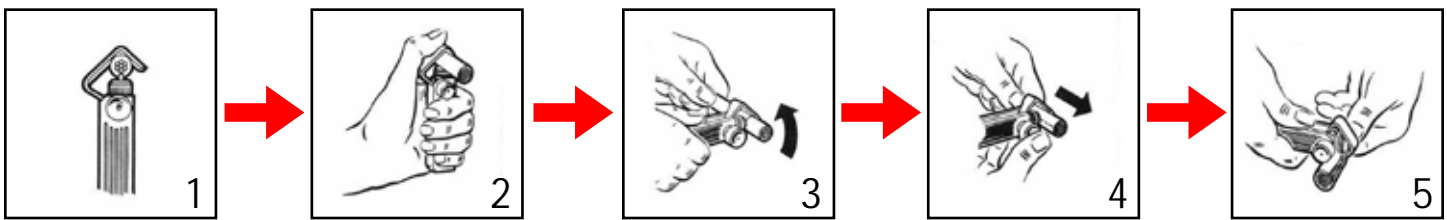

## Compression Tool



### **Reliability. Durability. Versatility.**

The JDV-UNV-659 is a high quality termination tool for use with compression-type connectors. Each tool is ergonomically designed and features a spring-loaded connector support that guarantees proper positioning and provides a consistent termination time after time.

With its lightweight and compact design, the JDV-UNV-659 can easily fit into your pocket.

- Unique jaw design enables cable to be inserted or removed with one hand.
- Factory-calibrated activators and gauges ensure accuracy.
- Spring-loaded 360° support guarantees proper positioning and consistent, reliable terminations.
- Small enough to fit into your pocket with ease.

## F CONNECTOR TOOL

JDV's FC100 installs and removes F connectors in tight spaces

- Unscrews tight connections and removes F connectors in high density and hard to reach locations
- Provides 30 in/lb tightening and untightening torque using only your fingers
- Prevents signal leakage and service calls from loose connections
- Equipped with plastic body and steel hex



# Cable Storage Equipment

## **NEW!** Cable Reel with Unique A-Frame

### LIGHTWEIGHT. DURABLE. WEATHER-RESISTANT.

JDV's new CR1000 is a reusable plastic cable reel with the same footprint as a standard 18-inch plywood reel that holds buried service wire. The CR1000 is a complete set, which consists of a hub, two twist-on flanges and a strong durable handle, and a high-quality A-frame stand.

Capacity indicators are imprinted on the flanges for estimating the amount of wire on the reel at all times. Since the reel is used with many different lengths and kinds of wire, the indicators are printed as percentages.

Both flanges can be adjusted out for a larger hub dimension in order to accommodate bigger wire rolls.

The CR1000 comes with an unique durable A-frame (p/n U2000) that can simply be converted into a handle within seconds. With this exceptional design, you can roll the wire reel around anywhere you go!

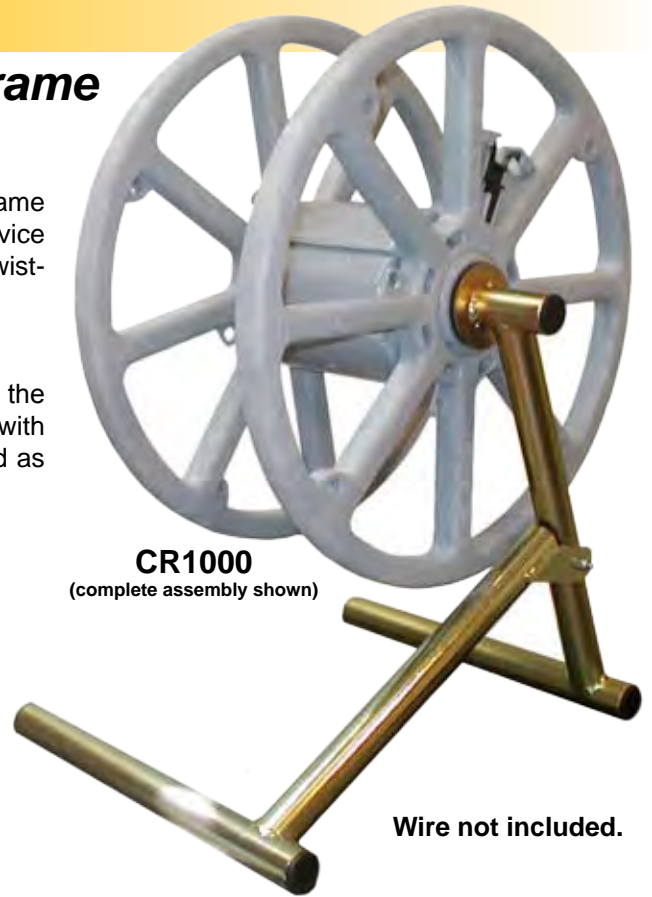

**CR1000**  
(complete assembly shown)

Wire not included.

Part No.	Description	Weight (lbs)
CR1000	Cable reel with stand (complete)	20.0
U1000	Reel assembly	9.5
U2000	"A" frame assembly	10.5

- Lightweight
- Stackable
- Reusable
- Cost-effective
- Improve safety
- User-friendly



Any wire can be used if it can be coiled to fit the ReelSaver!

Wire not included.

## **NEW!** ReelSaver

### COST-EFFECTIVE

The CR2000 is your economical solution! No more disposal fees and packaging waste. Minimize loss due to inaccurate measurement of remaining wire quantity. Save on storage and transportation cost by using a standard coiled wire, which maximizes cube efficiency.

### IMPROVE SAFETY

Eliminates twisted wires for on-site working technicians. The CR2000 is made of durable plastic, is compact, and lightweight.

### USER-FRIENDLY

Easy to operate, reload, and install a new wire coil in less than a minute.

### Capacity

Wire Type	Length*	Weight*
Arial drop wire 2 pair	500ft. (150m)	19.4lb (8.80kg)
Station wire (JKT)	1000ft to 1600ft (300m to 500m)	15.7lb (7.15kg)
Inside wire 3 pair	All types including plenum	1000ft (300m)
Inside wire 4 pair		1000ft (300m)

\* Length and Weight as approximate, and may vary depending on wire used.



JDV Products, Inc • 22-01 Raphael Street • Fair Lawn, NJ 07410 USA  
201-796-1720 • Fax 201-796-9399 • www.jdvproducts.com

# VESSEL®

## Heavy-Duty Utility Knives

These high quality utility knives are designed to take the abuse that would destroy ordinary knives. Any Electrician, Telephone Technician, or person doing general cable prep work should have one. Perfect for cutting and stripping wire or cable, opening utility outlets in plywood and sheetrock, or any general cutting application. There are three different models available, and each one comes with a locking sheath and a ceramic sharpening stone.



### VDK-1

Equipped with a special high-grade steel blade, the VDK-1 is the perfect item to add to your toolbox. This knife is ideal for electrical, service work, or for any general cutting application.



### VDK-3

The unique DAMASCUS blade of the VDK-3 is made from a 33 layer sandwich construction of soft steel and carbon steel. This blade is easy to sharpen and guarantees excellent cutting performance.

### VDK-5

The VDK-5, with its high-grade steel blade and glow-in-the-dark handle, greatly aid Electricians since most electrical work is performed in dark locations. The fluorescent handle requires only 2-3 minutes of exposure to sunlight or lamplight to "charge". Now any user will know exactly where the knife is at all times, helping to prevent accidents from occurring.



# Ceramic Adjustment Tools



## Features:

- Made from high quality Zirconia ceramic
- Ideal for adjustment of electronic parts, wireless equipment, TV, VCR, video cameras, radio equipment, computers, or communications equipment
- Anti-static, non-magnetic, and acid resistant



## 9000 Series

- Single tip screwdriver with free-turning knob



Part No.	EDP No.	mm					
		Tip Dia.	Tip Dia.	Tip Length	Tip Dia.	Tip Length	Tip Dia.
9000 0.9*30	125650	0.9	0.4	30	1.8	10	125
9000 1.3*30	125651	1.3	0.4	30	1.8	10	125
9000 1.8*30	125652	1.8	0.4	30	1.8	10	125
9000 2.6*30	125653	2.6	0.4	30	2.6	10	125
9000 3.4*15	125654	3.4	0.5	15	3.4	10	115
9000 P0*30	125655	+ No. 0		30	2.6	10	125
9000 P1.7*30	125656	+ No. 1.7		30	2.6	10	125

## Ceramic Adapters



- Replacement tips for: 9001, 9002, and 9003 Series
- Can be used with automatic regulators
- Single and double tip models

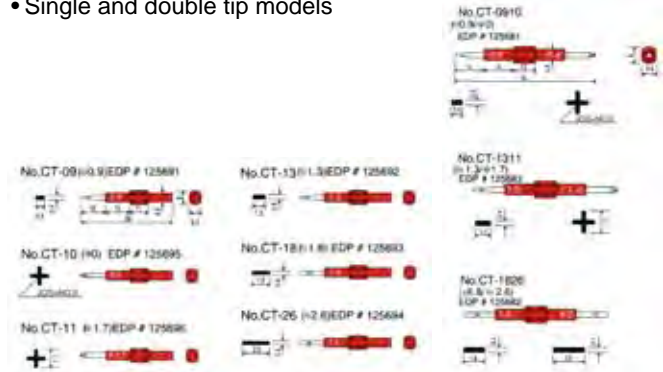

## 9001 Series

- Handle with four interchangeable ceramic tips



Part No.	EDP No.	Handle Dia.	O.A.L. (w/blade)	Handle Details	
		mm	mm	Blades	Length
9001	125661	11	145	(-)0.9 / (+)0 (-)1.8 / (+)2	71

## Ceramic Blades

- For use with automatic regulators

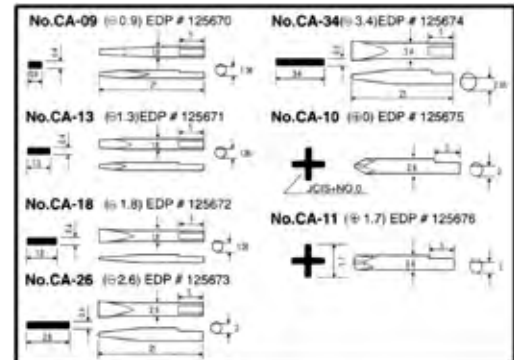

## 9002 & 9003 Series

- Handle with two interchangeable ceramic tips



Part No.	EDP No.	Handle Dia.	O.A.L. (w/blade)	Handle Details	
		mm	mm	Blades	Length
9002	125665	11	145	(-)0.9 & (-)1.8	71
9003	125666	11	145	(-)1.3 & (+)2.6	71

## INSTALLATION INSTRUCTIONS

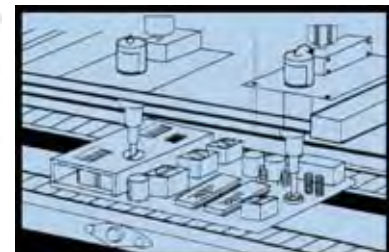
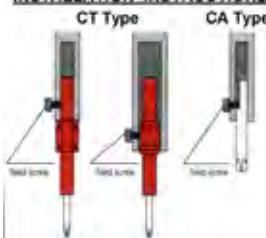

## 9900 Series Micro Screwdrivers

- Handle is fitted with revolving cap for fast turning
- Fully hardened chrome vanadium steel



Part No.	EDP No.	mm					
		Tip Width	Tip Thickness	Shank Dia.	Blade Length	Shank Length	O.A.L.
9900 1.8*50	125621	1.8	0.25	50	2.5	10	145
9900 2.5*75	125622	2.5	0.35	75	2.5	10	170
9900 3*100	125623	3	0.45	100	3	10	195
9900 3*150	125624	3	0.45	150	3	10	245
9900 P00*75	125625	+ No. 00	75	2.5	10	170	
9900 P0*100	125626	+ No. 0	100	3	10	195	
9900 P0*150	125627	+ No. 0	150	3	10	245	

**NEW!**

## 81L LED Current Detector



The NEW Model 81L is great for electricity testing of lighting, wiring, repair work on TV and radio, and oscillation test of wireless equipment. The bright, easy to view LED will illuminate when voltage is detected.

Part No.	EDP No.	Range of Voltage Detection
81L	125104	A.C.100V~240V
		D.C.100V~350V

## 205 Series Precision Screwdrivers



Part No.	EDP No.	Shank Length	Blade Width	Handle Diam.	O.A.L.
					mm
205 3.5	134002	33	3.5	8.0	126
205 3.0	134003	29	3.0	7.0	114
205 2.3	134004	26	2.3	6.0	104
205 1.8	134005	23	1.8	5.0	94
205 1.2	134006	20	1.2	4.5	85
205 0.9	134007	16	0.9	3.5	78
205 P0	134012	33	+ 0	8.0	126
205 P00	134013	29	+ 00	7.0	114

## 9900 Series Micro Screwdriver Sets

- For adjustment and repair of precision equipment, electronics, glasses, watches, etc.
- Set of frequently used sizes



Part No.	EDP No.	Set Includes (mm)
9902	125610	+00x75 / +0x100 / -1.8x50
9903	126611	+00x75 / -2.5x75 / -3x100

## TD36 Microturn Screwdriver Set

- Ideal for screw tightening in precision fields
- Designed for both turning and tightening
- High strength precision tip



Part No.	EDP No.	Set Includes (mm)
TD-36	250036	-1.4 / -1.8 / -2.3 / +00 / +0 / +1

## 205 Series Precision Screwdriver Sets

- Ideal for fastening and unfastening miniature screws.
- Metal handle can be freely turned from the butt end, therefore finger pressure is sufficient for maintaining the position while turning
- For repair and assembly of watches, cassettes, radios, glasses, precision equipment, plastic models, and much more.



Part No.	EDP No.	Set Includes (mm)
206	134001	-0.9 / 1.2 / 1.8 / 2.3 / 3.0 / 3.5
207	134011	-0.9 / 1.21 / 1.8 / 2.3 / +00 / +0

# Megadora Screwdrivers



The MEGADORA models are equipped with the most advanced triple-molded handle for comfort. The corners of the hexagonal cross-section are molded with elastomer for a soft fit and high torque transmission.



## 900 Standard & 920 Stubby Series



- Handle is fitted with revolving cap for fast turning
- Fully hardened chrome vanadium steel

Part No.	EDP #	mm					
		Bit Dia	Bit Length	Shank Dia	Shank Length	Handle Length	Total Length
900 5.5*75	125701	5.5	0.8	75	5.5	34	185
900 6*100	125702	6.0	0.9	100	6.4	34	210
900 6*150	125755	6.0	0.9	150	6.4	34	260
900 8*150	125704	8.0	1.1	150	8.0	36	275
900 P00*75	125741	+ No. 00		75	3.0	21	153
900 P0*75	125742	+ No. 0		75	3.0	21	153
900P1*75	125705	+ No. 1		75	5.5	34	185
900 P2*100	125706	+ No. 2		100	6.4	34	210
900 P3*150	125708	+ No. 3		150	8.0	36	275
920 6*25	125752	6.4	0.9	25	6.4	36	75
920 P1*25	125753	+ No. 1		25	6.4	36	75
920 P2*25	125754	+ No. 2		25	6.4	36	75

## 970 Series Chisel Screwdrivers



- Made of high grade chisel steel of HRC58 hardness
- Tang-Thru shank with large end cap
- Sound cutting and wear resistance
- Great for concrete bricks, ceramic tiles, deburring, corrosion scraping, frozen bolts and nuts, and spot welding stripping

Part No.	EDP #	mm					
		Bit Dia	Bit Length	Shank Dia	Shank Length	Handle Length	Total Length
970 7*100	125722	5.5	0.8	75	5.5	34	185
970 9.5*120	125732	6.0	0.9	100	6.4	34	210

## 970 Series Clip Removers



- Dual size blade covers standard 7mm and 12mm clip sizes
- Suited for many clips used in automobiles
- Fully hardened vanadium steel
- Chrome plated fork to enable damage-free sliding
- Optimally angled for working in cramped places (i.e. door trim, wire anchors, clips, etc.)
- Long type for reaching clips deep inside car interiors

Part No.	EDP #	mm				
		Blade Size	Blade Length	Shank Dia	Shank Length	Total Length
970 CR-300	125731	12/7	300	7.0	34	352
970 CR-120	125721	12/7	120	7.0	34	230

## 970 Series Scrapers



- Ideal for removing cross/P tile, paint, stickers, and other scraping needs
- Made of high strength die-cast metal
- Easy lever-operated blade replacement
- Plated finish is resistant to paint and adhesives

Part No.	EDP No.	mm			
		A	B	C	D
970 S-180	252201	195	85	-	34
970 S-300	252202	313	185	15	36
970 ST-300	252203	315	185	15	36

Replacement Blade: MSB-01 (100mm long)



JDV Products, Inc • 22-01 Raphael Street • Fair Lawn, NJ 07410 USA  
201-796-1720 • Fax 201-796-9399 • www.jdvproducts.com

The "Power-Grip" series are high precision tools ergonomically designed to the shape of the palm of your hand. Various grip sizes available according to tightening torque.



## 5400 Series Ultra Ball Hex Screwdrivers



Tapered to 35°, the ball tip is always at the center of rotation, ensuring smooth turning.



Part No.	EDP #	mm					
		Tip	Shaft	Tip	Shaft	Tip	Shaft
5400 H1.5*80	122847	1.5	80	2.5	155	17	
5400 H2*80	122848	2.0	80	3.0	155	17	
5400H2.5*80	122849	2.5	80	3.0	155	17	
5400 H3*120	122850	3.0	120	3.5	217	28	
5400 H4*120	122851	4.0	120	5.0	224	31.8	
5400 H5*120	122852	5.0	120	6.0	235	35.6	
5400 H6*120	122853	6.0	120	7.0	235	35.6	

## 5400TX Series Torx Screwdrivers



- Excellent torque transmission
- Outstanding durability
- No CAM-OUT
- Minimal damage to screws and tools

Part No.	EDP #	Tip Size	mm				
			Tip	Shaft	Tip	Shaft	Tip
5400TX 5*80	122854	T5	1.37	80	2.5	155	17.0
5400TX 6*80	122855	T6	1.65	80	2.5	155	17.0
5400TX 7H*80	122856	T7H	1.97	80	2.5	155	17.0
5400TX 8H*80	122857	T8H	2.3	80	3.0	155	17.0
5400TX 9H*80	122858	T9H	2.48	80	3.0	155	17.0
5400TX 10H*80	122859	T10H	2.72	80	3.0	155	17.0
5400TX 15H*80	122860	T15H	3.26	80	3.5	177	28.0
5400TX 20H*120	122861	T20H	3.84	120	4.0	217	28.0
5400TX 25H*120	122862	T25H	4.4	120	5.0	224	31.8
5400TX 27H*120	122863	T27H	4.96	120	5.0	224	31.8
5400TX 30H*120	122864	T30H	5.49	120	6.0	235	35.6
5400TX 40H*120	122865	T40H	6.6	120	7.0	235	35.6

## 4100 Series Nut Drivers



- Ideal for fastening and unfastening hexagon bolts and nuts

Part No.	EDP #	mm							
		Tip	Shaft	Tip	Shaft	Tip	Shaft	Tip	Shaft
4100 5*115	123501	5.0	8	18	115	5.0	28.0	212	
4100 5.5*115	123502	5.5	9	18	115	5.0	28.0	212	
4100 6*115	123503	6.0	9	18	115	5.5	28.0	212	
4100 7*125	123504	7.0	10	20	125	5.5	28.0	222	
4100 8*125	123505	8.0	12	20	125	5.5	31.8	229	
4100 9*125	123506	9.0	12	20	125	6.3	31.8	229	
4100 10*125	123507	10.0	15	20	125	7.0	35.6	240	
4100 11*125	123508	11.0	15	20	125	7.0	35.6	240	
4100 12*150	123509	12.0	17	20	150	8.0	35.6	265	
4100 13*150	123510	13.0	19	20	150	8.0	35.6	265	

## 4200 Series SUPADRIV Screwdrivers



The basic shape is a cross recess of 4 equally thick blades. The drive faces that the screwdriver contacts inside the recess are almost perpendicular, raising drive efficiency, minimizes slipping, and further enhancing the torque transfer and anti-CAM-OUT properties of the POZIDRIV.

Part No.	EDP #	mm				
		Tip	Shaft	Tip	Shaft	Tip
4200 SDV1*75	636001	SDV No. 1	75	5	28	172
4200 SDV2*100	636002	SDV No. 2	100	6	31	204
4200 SDV3*150	636003	SDV No. 3	150	8	35	265

## 4600 Series POZIDRIV Screwdrivers



The basic shape is a cross recess of 4 equally thick blades. This prevents annoying CAM-OUT and transmits strong torque to the screws.

Part No.	EDP #	mm				
		Tip	Shaft	Tip	Shaft	Tip
4600 PZ1*75	636011	PZD No. 1	75	5	28	172
4600 PZ2*100	636012	PZD No. 2	100	6	31	204
4600 PZ3*150	636013	PZD No. 3	150	8	35	265

# Ball Grip Screwdrivers



Ergonomically designed "Ball-Grip" handles fit comfortably in the palm of your hand while ensuring the operator maximum torque while tightening.

## 220 Series - Standard Type



- Transmits ample tightening force to screw
- Cushion grip color-coded by +/-
- Fully hardened chrome vanadium steel
- High precision black point tip
- Magnetized

Part No.	EDP No.	mm					
		Tip Width	Tip Thickness	Shank Diameter	Shank Length	Head Diameter	Head Length
220 5.5*75	125351	5.5	0.8	75	5.5	32	156.5
220 5.5*100	125361	5.5	0.8	100	5.5	32	181.5
220 5.5*150	125362	5.5	0.8	150	5.5	32	231.5
220 6*100	125352	6.0	0.9	100	6.4	41	200
220 6*150	125353	6.0	0.9	150	6.4	41	250
220 6*200	125354	6.0	0.9	200	6.4	41	300
220 P1*75	125355	+ No.1		75	5.5	32	156.5
220 P1*100	125371	+ No.1		100	5.5	32	181.5
220 P1*150	125372	+ No.1		150	5.5	32	231.5
220 P2*100	125356	+ No.2		100	6.4	41	200
220 P2*150	125357	+ No.2		150	6.4	41	250
220 P2*200	125358	+ No.2		200	6.4	41	300

## 220JF Series - JAWSFIT Type



Part No.	EDP No.	mm				
		Tip Width	Tip Thickness	Shank Diameter	Shank Length	
220JF P2*100	125514	+ No.2		100	41	200
220JF P2*150	125515	+ No.2		150	41	250

## 225 Series - Insulated Type



- Shank is covered with resin for excellent safety
- Solid built body offers extra fastening power
- Cushion grip color-coded by +/-
- Fully hardened chrome vanadium steel
- Magnetized

Part No.	EDP No.	mm					
		Tip Width	Tip Thickness	Shank Diameter	Shank Length	Head Diameter	Head Length
225 6*100	125382	6.0	0.9	100	41	200	
225 6*150	125383	6.0	0.9	150	41	250	
225 P2*100	125389	+ No.2		100	41	200	
225 P2*150	125390	+ No.2		150	41	250	

## 230 Series - Tang-Thru Type



- Tang-Thru shank with star end cap
- Fully hardened Chrome Vanadium steel shank
- Different color for (+) and (-)
- Cushion grips
- Magnetic tips

Part No.	EDP No.	mm					
		Tip Width	Tip Thickness	Shank Diameter	Shank Length	Head Diameter	Head Length
230 5.5*75	125311	5.5	0.8	75	5.5	32	156.5
230 6*100	125314	5.5	0.8	100	6.4	41	200
230 6*150	125315	5.5	0.8	150	6.4	41	250
230 P1*75	125321	+ No.1		75	5.5	32	156.5
230 P2*100	125324	+ No.2		100	6.4	41	200
230 P2*150	125325	+ No.2		150	6.4	41	250



The "CRYSTALLINE" models are designed with a bright quartz hexagonal cross-sectioned handle, which accurately transmits torque to the screw.



## 6200 Stubby & 6300 Standard Series



- Fully hardened chrome vanadium steel
- Magnetized

Part No.	EDP #	mm					
		Tip	Tip	Shank	Shank	Shank	Shank
6300 4.5*50	121201	4.5	0.6	50	5.0	22.0	138
6300 5.5*75	121202	5.5	0.7	75	5.5	22.0	163
6300 6*100	121203	6.0	0.8	100	6.0	25.0	198
6300 7*125	121204	7.0	0.9	125	7.0	28.5	238
6300 8*150	121205	8.0	1.0	150	8.0	28.5	263
6300 9*200	121206	9.0	1.1	200	9.0	30.0	320
6300 10*250	121207	10	1.2	250	9.0	30.0	370
6300 10*300	121208	10	1.2	300	9.0	30.0	420
6300 P1*75	121209	+ No.1		75	5.0	22.0	163
6300 P2*100	121210	+ No.2		100	6.0	25.0	198
6300 P3*150	121211	+ No.3		150	8.0	28.5	263
6300 P4*200	121212	+ No.4		200	9.0	30.0	320
6200 6*38	121101	6.0	0.8	38	6.0	28.5	86
6200 P1*38	121102	+ No. 1		38	6.0	28.5	86
6200 P2*38	121103	+ No. 2		38	6.0	28.5	86

## 6300 Long Shank Series



- Long shaft hard to reach places
- Magnetized

Part No.	EDP #	mm					
		Tip	Tip	Shank	Shank	Shank	Shank
6300 5*150	121213	5.0	0.7	150	4.8	25	248
6300 5*200	121214	5.0	0.7	200	4.8	25	298
6300 5*250	121215	5.0	0.7	250	4.8	25	348
6300 P1*150	121216	+ No.1		150	4.8	25	248
6300 P1*200	121217	+ No.1		200	4.8	25	298
6300 P1*250	121218	+ No.1		250	4.8	25	348
6300 P2*150	121219	+ No.2		150	6.0	25	248
6300 P2*200	121220	+ No.2		200	6.0	25	298
6300 P2*250	121221	+ No.2		250	6.0	25	348

## 8506HX & 8509HX Hex Key Wrench Sets



Part No.	EDP #	Sizes Included (mm)
8506HX	144290	1.5 / 2 / 2.5 / 3 / 4 / 5
8509HX	144291	1.5 / 2 / 2.5 / 3 / 4 / 5 / 6 / 8 / 10

## 8606HX & 8609HX Hex Key Wrench Sets



Part No.	EDP #	Sizes Included (mm)
8606HX	144270	1.5 / 2 / 2.5 / 3 / 4 / 5
8609HX	144271	1.5 / 2 / 2.5 / 3 / 4 / 5 / 6 / 8 / 10

## 8506BP & 8509BP Ultra Ball Wrench Sets



Part No.	EDP #	Sizes Included (mm)
8506BP	144130	1.5 / 2 / 2.5 / 3 / 4 / 5
8509BP	144131	1.5 / 2 / 2.5 / 3 / 4 / 5 / 6 / 8 / 10

## 8606BP & 8609BP Ultra Ball Wrench Sets



Part No.	EDP #	Sizes Included (mm)
8606BP	144040	1.5 / 2 / 2.5 / 3 / 4 / 5
8609BP	144041	1.5 / 2 / 2.5 / 3 / 4 / 5 / 6 / 8 / 10

# 1000V Insulated Hand Tools

All our hand tools are rated for 1,000V AC live line use, but tested up to 10,000V AC. These tools comply or exceed ASTM F1505 standards and they comply with IEC 900 Standards for Insulated Hand Tools. They meet OSHA 1910.333(c) (2) and NFPA 70E 2000 requirements. All the hand tools are impact resistant and flame retardant. Our tools are two color insulated for added safety. If the yellow underlayer is showing, the tool may no longer be insulated properly.

We also maintain the ability to modify any tool not in this catalog to your specific requirements.

JDV realizes that in every industry there are sets of tools unique to many jobs. Why buy sets that have unneeded tools?

JDV will customize your set to meet your specific requirements, and package these sets in customized rolls or boxes!!!

## We can make custom sets according to your specifications

### 1000V Sockets



**3/8" Drive Socket Standard  
(12 Point)**

Part No.	Size
X2045208	1/4"
X2045210	5/16"
X2045212	3/8"
X2045214	7/16"
X2045216	1/2"
X2045218	9/16"
X2045120	5/8"
X2045122	11/16"
X2045124	3/4"
X2045126	13/16"
X2045128	7/8"
X2045130	15/16"
X2045132	1"



**1/2" Drive Socket Standard  
(12 Point)**

Part No.	Size
X2040212	3/8"
X2040214	7/16"
X2040216	1/2"
X2040218	9/16"
X2040120	5/8"
X2040122	11/16"
X2040124	3/4"
X2040126	13/16"
X2040128	7/8"
X2040130	15/16"
X2040132	1"
X2040134	1-1/16"
X2040136	1-1/8"



**3/8" Drive Hex Bit Sockets**

Part No.	Size
X2041201	1/16"
X2041202	5/64"
X2041203	3/32"
X2041204	7/64"
X2041205	1/8"
X2041206	9/64"
X2041207	5/32"
X2041208	3/16"
X2041209	7/32"
X2041210	1/4"
X2041211	5/16"
X2041212	3/8"

Metric sizes offered in 2-12mm

**3/8" Drive Socket Deep  
(12 Point)**

Part No.	Size
X2042408	1/4"
X2042410	5/16"
X2042412	3/8"
X2042414	7/16"
X2042416	1/2"
X2042418	9/16"
X2042420	5/8"
X2042422	11/16"
X2042424	3/4"
X2042426	13/16"
X2042428	7/8"
X2042430	15/16"
X2042432	1"

**1/2" Drive Socket Deep  
(12 Point)**

Part No.	Size
X2040812	3/8"
X2040814	7/16"
X2040816	1/2"
X2040818	9/16"
X2040820	5/8"
X2040822	11/16"
X2040824	3/4"
X2040826	13/16"
X2040828	7/8"
X2040830	15/16"
X2040832	1"
X2040834	1-1/16"
X2040836	1-1/8"

**1/2" Drive Hex Bit Sockets**

Part No.	Size
X2041213	5/16"
X2041214	3/8"
X2041215	7/16"
X2041216	1/2"
X2041218	9/16"
X2041220	5/8"
X2041266	1/2" Long
X2041268	9/16" Long
X2041270	5/8" Long

Metric sizes offered in 12-17mm

**Hex Bit Sockets also  
available in 1/4" drive.**

Also available in 1/4" & 3/4" Drives. Metric sizes offered in 4-36mm  
For 6 point sockets add"-6" after part number

## LOOK FOR SETS ON PAGES 38-39



**JDV Products, Inc • 22-01 Raphael Street • Fair Lawn, NJ 07410 USA**  
201-796-1720 • Fax 201-796-9399 • [www.jdvproducts.com](http://www.jdvproducts.com)

# 1000V Ratchets & Extensions



Detail of Flare Nose style extensions for use with non-booted sockets



## Extensions

Part No.	OAL	Drive
X2045159	1.5"	3/8"
X2045160	3"	3/8"
X2045161	6"	3/8"
X2045158	9"	3/8"
X2045162	12"	3/8"
X2045163	18"	3/8"
X2045164	24"	3/8"
X2045149	35"	3/8"
X2040160	2"	1/2"
X2040161	5"	1/2"
X2040162	10"	1/2"
X2040163	20"	1/2"

\* Add "FN" for close quarters sockets  
Also available in 1/4" and 3/4" drives



## Fiberglass Extensions

Part No.	OAL	Drive
X2045161FB	6"	3/8"
X2045162FB	12"	3/8"
X2040164FB	6"	1/2"
X2040165FB	12"	1/2"

Fiberglass extensions tested at 80ft/lbs.  
DO NOT EXCEED 60ft/lbs.



## Ratchets

Part No.	OAL	Drive
X2040970	4.5"	1/4"
X2045170	7.6"	3/8"
X2045179 LONG	10.3"	3/8"
X2042470	10.3"	1/2"

Also available in 3/4" drive



## Hex Wrench - "L" Long Handle

Part No.	Size
X262223	1/16"
X262224	5/64"
X262225	3/32"
X262226	7/64"
X262227	1/8"
X262228	9/64"
X262229	5/32"
X262231	3/16"
X262233	7/32"
X262235	1/4"
X262239	5/16"
X262243	3/8"
X262247	7/16"
X262251	1/2"

Available up to 1-1/8"  
Metric sizes offered in 2-12mm



## Hex Wrench - "T" Long Handle (6" Long)

Part No.	Size
X2631605	5/64"
X2631606	3/32"
X2631607	7/64"
X2631608	1/8"
X2631609	9/64"
X2631610	5/32"
X2631612	3/16"
X2631614	7/32"
X2631616	1/4"
X2631620	5/16"
X2631624	3/8"
X2651628	7/16"
X2651632	1/2"
X2651634	9/16"

Available up to 1-1/8"  
Metric sizes offered in 0.7-36mm

# 1000V Hex Wrenches



# 1000V Wrenches



## Open Ended

Part No.	Size
X2488408	1/4"
X2488410	5/16"
X2488412	3/8"
X2488414	7/16"
X2488416	1/2"
X2488418	9/16"
X2488420	5/8"
X2488422	11/16"
X2488424	3/4"
X24C26	13/16"
X24C28	7/8"
X24C30	15/16"
X24C32	1"
X24C34	1-1/16"
X24C36	1-1/8"
X24C40	1-1/4"

Available up to 2"  
Metric sizes offered in 7-36mm



## Box/Closed Ended

Part No.	Size
X2488408-B	1/4"
X2488410-B	5/16"
X2488412-B	3/8"
X2488414-B	7/16"
X2488416-B	1/2"
X2488418-B	9/16"
X2488420-B	5/8"
X2488422-B	11/16"
X2488424-B	3/4"
X24C26-B	13/16"
X24C28-B	7/8"
X24C30-B	15/16"
X24C32-B	1"
X24C34-B	1-1/16"
X24C36-B	1-1/8"
X24C40-B	1-1/4"

Available up to 2"  
Metric sizes offered in 7-36mm



## Ratcheting Box Wrenches

Part No.	Size
X249008	1/4"
X249010	5/16"
X249011	11/32"
X249012	3/8"
X249014	7/16"
X249016	1/2"
X249018	9/16"
X249020	5/8"
X249022	11/16"
X249024	3/4"
X249026	13/16"
X249028	7/8"
X249030	15/16"
X249032	1"
X249034	1-1/16"
X249036	1-1/8"
X249038	1-1/4"

Available up to 2-1/8"  
Metric sizes offered in 6-36mm



## Adjustable

Part No.	OAL	Jaw Opening
X24804	4"	1/2"
X24806	6"	15/16"
X24808	8"	1-1/8"
X24810	10"	1-5/16"
X24812	12"	1-1/2"
X24815	15"	1-11/16"

Available up to 24" OAL  
(2-7/16" Jaw Opening)



## Torque Wrench

Part Number	OAL	Size Drive	Torque (In/Lb)
X22TCI-150RA38	10"	3/8"	30-150

A wide variety of Torque Wrenches are available upon request

## 1000V Inspection Mirror





## Standard Screwdrivers

Part No.	Description
X2376802	1/8" x 2" Shaft
X2375904	3/16" x 4" Shaft
X2375906	3/16" x 6" Shaft
X2375910	3/16" x 10" Shaft
X2375704	1/4" x 4" Shaft
X2375705	1/4" x 6" Shaft
X2375706	5/16" x 6" Shaft
X2375708	3/8" x 8" Shaft
X2375710	3/8" x 10" Shaft
X2375712	3/8" x 12" Shaft
X2376302	# 0 x 2" Shaft
X2376103	# 1 x 3" Shaft
X2376102	# 2 x 1-1/2" Shaft
X2376104	# 2 x 4" Shaft
X2376105	# 2 x 6" Shaft
X2376106	# 3 x 6" Shaft
X2376108	# 4 x 8" Shaft



## Nutdrivers w/ Cushion Grip

Part No.	Description
X2542010	3/16" x 3" Shaft
X2542030	1/4" x 3" Shaft
X2542050	5/16" x 3" Shaft
X2542060	11/32" x 3" Shaft
X2542070	3/8" x 3" Shaft
X2542080	7/16" x 3" Shaft
X2542090	1/2" x 3" Shaft
X2542100	9/16" x 3" Shaft
X2542110	5/8" x 3" Shaft

Also available with 6" Cushion Grip  
Metric sizes offered in 5-12mm



## Torque Screwdriver

Part No.	OAL	Drive	Torque
X22TS35	6-3/8"	1/4"	1-36in/lb



## Torx Screwdrivers

Part No.	Description
X2341410	T10 x 3" Shaft
X2341415	T15 x 3" Shaft
X2341420	T20 x 3" Shaft
X2341425	T25 x 3" Shaft
X2341427	T27 x 4" Shaft
X2341430	T30 x 4" Shaft
X2341440	T40 x 6" Shaft
X2341445	T45 x 6" Shaft
X2341450	T50 x 6" Shaft



## Magnetic Bit Screwdriver

Part No.	Bits Included			
X2742614	3/16"	1/4"	# 1	# 2



## Magnetic Screw Starter

Part No.	Description
X27500-6	6" Slotted
X27700-6	6" Phillips



### Part No. X23871

Screwdriver Set  
Includes: #1x3", #2x4", 1/8"x2",  
3/16"x6", 1/4"x4", 5/16"x6"  
Packaged in a roll

### Part No. X23869

Screwdriver Set  
Includes: #1x3", #2x4", 1/8"x2",  
3/16"x6", 3/16"x10", 1/4"x4",  
5/16"x6", 3/8"x8"  
Packaged in a roll

### Part No. X23870

Screwdriver Set  
Includes: #1x3", #2x4", #3x6", 1/8"x2",  
3/16"x6", 3/16"x10",  
1/4"x4", 5/16"x6", 3/8"x8", 3/8"x12"  
Packaged in a roll

## Nutdriver Sets



### Part No. X25922

3" Nutdriver Set  
Includes: 3/16", 1/4", 5/16", 11/32",  
3/8", 7/16", 1/2", 9/16", 5/8"  
Packaged in a roll

### Part No. X25925

3" Metric Nutdriver Set  
Includes: 5mm, 6mm, 7mm, 8mm,  
9mm, 10mm, 11mm, 12mm  
Packaged in a roll



# 1000V Pliers & Cutters



**Fiberglass Plier**

Part No.	OAL	Jaw Opening
XKN9862	8"	1-1/2"



**Linesman Pliers**

Part No.	OAL	Description
21347	7"	Rounded Nose
X21348	8-1/2"	Rounded Nose
X21369	9"	High Leverage



**Cutting Pliers**

Part No.	OAL
X21436	6"
X21437	7"



**Cable Cutter**

Part No.	OAL
X21911	9-1/2"



**Crimping Tool & Wire Cutter**

Part Number	OAL	AWG
X211005	9-3/4"	10-22



**Tongue and Groove Pliers**

Part No.	OAL	Capacity
X21426	6-1/2"	7/8"
X21430	10"	2"



**Wire Stripper-Cutter**

Part No.	AWG
X2111045	10-18



**Ratcheting Cable Cutter**

Part No.	Alum.	Copper
X2163060	600 MCM	400 MCM



## Open-End Wrench Set

Part No.	Description
<b>X241713</b>	13pc Set Includes 1/4" - 1"



## L Handle Hex Wrench Set

Part No.	Description
<b>X2610214</b>	13pc Set Includes 1/4" - 1"
<b>X2610614</b>	14pc Set Includes .09-17mm



## Battery Torque Wrench Set

Part No.	Description
<b>X202</b>	4pc Set Battery Torque Set

*Includes:* 3/8" Drive Torque Wrench (10" OAL, 30-150in/lb) 7" Fiberglass Extension, 1/2" Box Wrench, 1/2" 6pt Socket



## Closed-End Wrench Set

Part No.	Description
<b>X241713-B</b>	13pc Set Includes 1/4" - 1"



## T Handle Hex Wrench Set

Part No.	Description
<b>X2613P</b>	13pc Set Includes 5/64" - 1/2"



## Ratchet and Socket Sets

Part No.	Description
<b>X104</b>	16pc Standard Socket Set 3/8" Drive, Deep Sockets

*Includes:* Ratchet, 3" and 6" Extensions, 1/4, 5/16, 3/8, 7/16, 1/2, 9/16, 5/8, 11/16, 3/4, 13/16, 7/8, 15/16, and 1" Sockets (12pt)

Part No.	Description
<b>X106</b>	24pc Metric Socket Set 3/8" Drive, Deep Sockets

*Includes:* Ratchet, 3" and 6" Extensions, 6mm - 26mm Sockets (6pt and 12pt)



## Electrician Tool Set

Part No.	Description
<b>XTK9</b>	9pc Electrician Roll

*Includes:* 3/16x4", 3/16x6", 1/4x6" Slotted Screwdrivers, #1x3", #2x4" Phillips Screwdrivers, 7" Needle Nose Plier, 7-1/2" Diagonal Cutting Plier, 9" Linesman Plier, Combination Stripper/Crimper

**We can make custom sets according to your specifications**



# 1000V Tool Sets



Part No.	Description
<b>X204946</b>	13pc 1/4" Drive Close Quarters Socket Set

Includes: Ratchet; 3" and 6" Flared Extensions; 3/16, 7/32, 1/4, 9/32, 5/16, 11/32, 3/8, 7/16, 1/2, and 9/16" Regular Sockets (12pt)

Part No.	Description
<b>X204653</b>	16pc 3/8" Drive Close Quarters Socket Set

Includes: Ratchet; 3" and 6" Flared Extensions; 1/4, 5/16, 3/8, 7/16, 1/2, 9/16, 5/8, 11/16, 3/4, 13/16, 7/8, 15/16, and 1" Regular Sockets (12pt)

Part No.	Description
<b>X204121</b>	21pc 1/2" Drive Close Quarters Socket Set

Includes: Ratchet; 5" Flared Extension; 3/8, 7/16, 1/2, 9/16, 5/8, 11/16, 3/4, 13/16, 7/8, 15/16, 1, 1-1/16, 1-1/8, 1-3/16, 1-1/4, 1-5/16, 1-3/8, 1-7/16, and 1-1/2" Regular Sockets (12pt)



Part No.	Description
<b>X10TK60</b>	60pc General Maintenance Box

Includes: 1/8x2", 3/16x4", 3/16x6", 1/4x6", 5/16x6" Slotted Screwdrivers; #2x4", #2x8" Phillips Screwdrivers; 3/16, 1/4, 5/16, 11/32, 3/8, 7/16, 1/2 Nutdrivers (6" Long); Torque Wrench (30-150in/lb); 3/8" Drive Reversible Ratchet; 3" and 6" Extensions; 10pcs 5/16" - 7/8" Deep Sockets; 11pcs 3/8" - 1" Type L Hex Wrenches (6"); 7-1/2" Diagonal Cutting Plier; 8" Needle Nose Plier; 9" Linesman Plier; 9-1/2" Cable Cutting Plier; 10" Water Pump Plier; Combination Stripper/Crimper

Part No.	Description
<b>X10TK25</b>	25pc Outside Maintenance Box

Includes: 1/4x6" Narrow Tip & #2x6" Phillips Screwdrivers; 3/8x3", 7/16x3", 1/2x3", 9/16"x3" Nutdrivers; Torque Wrench (30-150in/lb); Reversible 3/8" Drive Ratchet; 3", 6", and 12" Extensions; 8pcs 3/8" - 13/16" Deep Sockets; 3/16", 1/4", 5/16", and 3/8" Type L Hex Wrenches (6"); 10" Water Pump Plier



Part No.	Description
<b>X10TK23</b>	24pc Basic Toll Power Connecting Toolbox

Includes: Close Quarters Socket set w/ 3/8" Drive Ratchet; 3" and 6" Flared Extensions; 1/4", 5/16", 3/8", 7/16", 1/2", 9/16", 5/8", 11/16", 3/4", 13/16", 7/8", 15/16", and 1" Sockets (12pt); 6" Adjustable Wrench; 3/16", 1/4", 5/16", 11/32", 3/8", 7/16", 1/2" Nutdrivers (3")

**THIS SET IS DESIGNED FOR USE IN TIGHT WORK SPACES**



Part No.	Description
<b>X101</b>	16pc Telecommunication Toolbox

Includes: 3/8" Drive Ratchet; 3/8" Drive 10" Torque Ratchet (30-250in/lb); 3" Extension; 3/8", 7/16", 1/2", 9/16" Regular Sockets (12pt); 5/8" Deep Socket; 9" Linesman Plier; 6" Needle Nose Plier; 8" Slip Joint Plier; 3/16x4", 1/4x6", 5/16x6", 3/8x8" Slotted Screwdrivers; #2x6" Phillips Screwdriver

**We can make custom sets according to your specifications**



**JDV Products, Inc • 22-01 Raphael Street • Fair Lawn, NJ 07410 USA**  
**201-796-1720 • Fax 201-796-9399 • www.jdvproducts.com**

Effective and secure fastening of screws is indispensable in improved work efficiency and increased reliability in mass production assembly factories. Good bits play a vital role in improved product quality and cost reduction. The accurately machined tip configuration of VESSEL bits will match any screw head perfectly. We offer a wide selection of products and customer service in order to help you select and use the appropriate VESSEL bit for any application.

VESSEL is known for their high quality and ensures that every product supplied is manufactured and tested to the relevant quality and production standards as JIS (Japanese Industrial Standard) and DIN requirements.

### For Safety Use:

- Avoid over-torque, over-load
- Do not idle tool in free speed with bit attached to it
- Do not use hand tool bits for power tools
- Before tools put on services for installing or replacing bits, be sure to disconnect the power supply. Otherwise, these tools may operate accidentally during their replacement or come off during operation, resulting in accidents, which is dangerous
- During the operation, the bits and screws are heated due to friction. Therefore, do not touch them

### NOTE:

Special order bits may take 6-8 weeks. If bits are not in stock, the minimum order is 200 pcs. Dimensions and specifications are subject to change without notice in advance.

## Insert Bits & Holders



**HAM**

The HAM bit holder accepts 1/4" (6.35mm) hex drive insert bits, and only has a 75mm O.A.L.



**MBC-BLUE**

The MBC-BLUE is a unique magnetic bit holder perfect for repetitive screw fastening. With its powerful magnet, screws can be held in place in horizontal and vertical positions while a retainer ring secures the bit inside the blue anodized holder. Equipped with a quick release chuck and accommodates 1/4" hex insert bits.

Part #	Model #	OAL (mm)
482415	HAM (Magnetic)	75
486345	MBC-BLUE (Magnetic)	68

### Cross Recessed

Part #	Model #	Tip x L
489001	3000/25	P0 x 1"
489002	3001/25	P1 x 1"
489003	3002/25	P2 x 1"

### Cross

Part #	Model #	Tip x L
487105	1001	P1 x 1"
487106	1002	P2 x 1"
487107	1003	P3 x 1"

### Slot Recessed

Part #	Model #	Tip x L
489061	5603/25	3x0.65x1"
489062	5604/25	4x0.7x1"
446389	5655/25	5.5x0.8x1"
489065	5606/25	6x0.85x25"
489066	5607/25	7x1.2x1"
489067	5608/25	8x1x25"

### Hex

Part #	Model #	Tip x L
487130	2001	1/8" x 25mm
489051	3032/25	2 x 25mm
489052	30325/25	2.5 x 25mm
489053	3033/25	3 x 25mm
489054	3034/25	4 x 25mm
489055	3035/25	5 x 25mm
489056	3036/25	6 x 25mm
489057	3038/25	8 x 25mm

### Square Head

Part #	Model #	Tip x L
487150	3001	1 x 1"
487151	3002	2 x 1"
487152	3003	3 x 1"

### Torx Recessed

Part #	Model #	Tip x L
489160	T10/25	T10 x 1"
489161	T15/25	T15 x 1"
489162	T20/25	T20 x 1"
489163	T25/25	T25 x 1"
489165	T30/25	T30 x 1"
489166	T40/25	T40 x 1"

## Double End Bits & Holder

### Features:

- One touch insertion and quick release
- Accepts both single-end and Double-end bits
- Perfect bit holding without any "play" between bit and holder
- Utilizes a precision engineered steel sheet spring to firmly grab bits without failure



**DBH-02**

Accepts all bits listed above, as well as Double-End bits

Part #	Model #	OAL (mm)
482433	DBHM-01 (Magnetic)	60
482434	DBHM-02 (Magnetic)	62

### DOUBLE END BITS

TIP	Part #	Model #	Tip x L
+	482435	P1D	1 x 30
	482436	P2D	2 x 30
	482437	P3D	3 x 30
*	482438	PZ1D	1 x 30
	482439	PZ2D	2 x 30
	480440	PZ3D	3 x 30
-	482441	4MMD	4 x 30
	482442	5MMD	5 x 30
	482443	6MMD	6 x 30

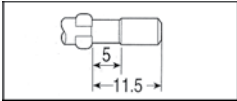

φ 4mm Shank Drive



Part #	Model #	Tip	Shaft Dia. (mm)	OAL (mm)
446001	D73	00	1.2	40
446002	D73	00	1.2	60
483001	D73	00	1.5	40
483002	D73	00	1.5	60
446004	D73	00	1.7	40
446005	D73	00	1.7	60
483005	D73	00	2	40
483006	D73	00	2	60
446006	D73	00	2	80
446007	D73	00	2	40
446008	D73	00	2	60
446009	D73	00	2	80
446010	D73	00	2	60
446011	D73	00	2	80
446012	D73	00	2	100
446013	D73	00	2	60
446014	D73	00	2	80
446015	D73	00	2	100



446016	D73	0	1.4	40
446017	D73	0	1.4	60
446018	D73	0	1.4	80
446019	D73	0	1.4	60
446020	D73	0	1.4	80
446021	D73	0	1.4	100
483010	D73	0	1.7	40
483011	D73	0	1.7	60
446023	D73	0	1.7	60
446024	D73	0	1.7	80
446025	D73	0	2	40
446026	D73	0	2	60
446027	D73	0	2	80
446028	D73	0	2	100
446030	D73	0	2	80
446031	D73	0	2	100
483015	D73	0	2.5	40
483016	D73	0	2.5	60
446033	D73	0	2.5	80
446034	D73	0	2.5	100
446036	D73	0	2.5	80
446037	D73	0	2.5	100
446038	D73	0	3	40
446039	D73	0	3	60
446040	D73	0	3	80
446041	D73	0	3	100
446042	D73	0	3	80
446043	D73	0	3	100
446044	D73	0	4	40
446045	D73	0	4	60



Part #	Model #	Tip	Shaft Dia. (mm)	OAL (mm)
446046	D73	1	2.2	40
446047	D73	1	2.2	60
446048	D73	1	2.5	40
446049	D73	1	2.5	60
446050	D73	1	2.5	60
446051	D73	1	2.5	80
446052	D73	1	2.5	100
483021	D73	1	3	40
446053	D73	1	3	60
446054	D73	1	3	80
446055	D73	1	3	100
446056	D73	1	3	60
446057	D73	1	3	80
446058	D73	1	3	100
483025	D73	1	4	40
446059	D73	1	4	60
446060	D73	1	4	80
446061	D73	1	4	100
446062	D73	1	4	120



446063	D73	2	3	40
446064	D73	2	3	60
446065	D73	2	3	80
446066	D73	2	3	60
446067	D73	2	3	80
446068	D73	2	3	100
446069	D73	2	3	120
483031	D73	2	4	40
446070	D73	2	4	60
446071	D73	2	4	80
446072	D73	2	4	100
446073	D73	2	4	120



Part #	Model #	Tip	Shaft Dia. (mm)	OAL (mm)
446074	D73	1.1	0.28	40
446075	D73	1.1	0.28	60
446076	D73	1.1	0.28	80
446077	D73	1.3	0.28	40
446078	D73	1.3	0.28	60
446079	D73	1.3	0.28	80
446080	D73	1.5	0.30	40
446081	D73	1.5	0.30	60
446082	D73	1.5	0.30	80
446083	D73	1.7	0.30	40
446084	D73	1.7	0.30	60
446085	D73	1.7	0.30	80
446086	D73	1.8	0.40	40
446087	D73	1.8	0.40	60
446088	D73	1.8	0.40	80

FOR USE WITH:  
DELVO (DENSEI), HIOS (FERRA TOOLS)



446107	D73	5	2	40
446108	D73	5	2	60
446109	D73	6	2	40
446110	D73	6	2	60
446111	D73	6	4	60
446112	D73	6	4	100
446113	D73	7	2	60
446114	D73	7	4	60
446115	D73	7	4	100
446116	D73	8H	4	60
446117	D73	8H	4	100
446118	D73	8H	4	150
446119	D73	10H	4	60
446120	D73	10H	4	100
446421	D73	10H	4	150
446422	D73	15H	4	60
446123	D73	15H	4	100

\* H = Tamper Proof

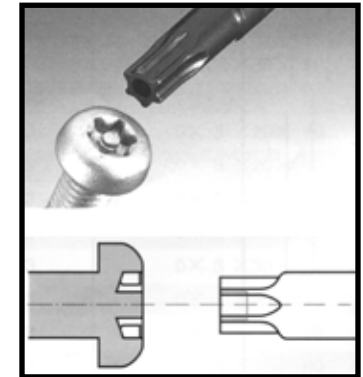

446089	D73	2	0.40	40
446090	D73	2	0.40	60
446091	D73	2	0.40	80
446092	D73	2.3	0.40	40
446093	D73	2.3	0.40	60
446094	D73	2.3	0.40	80
446095	D73	2.5	0.40	40
446096	D73	2.5	0.40	60
446097	D73	2.5	0.40	80
446098	D73	2.8	0.40	40
446099	D73	2.8	0.40	60
446100	D73	2.8	0.40	80
446101	D73	3	0.40	40
446102	D73	3	0.40	60
446103	D73	3	0.40	80
446104	D73	4	0.60	40
446105	D73	4	0.60	60
446106	D73	4	0.60	80

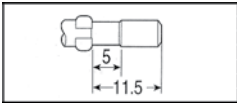

FOR USE WITH:  
HIOS (FERRA TOOLS)

## φ 5mm Shank Drive



Part #	Model #	Tip	Shaft Dia. (mm)	OAL (mm)
483105	D76	00	2	60
446258	D76	0	2.5	40
483115	D76	0	2.5	60
446252	D76	0	2.5	80
446260	D76	0	3	60
446261	D76	0	5	60
446262	D76	1	2.6	60
446263	D76	1	2.6	80
446264	D76	1	2.6	100
446265	D76	1	2.6	120
446266	D76	1	3	40
483121	D76	1	3	60
446267	D76	1	3	80
446268	D76	1	3	100
446269	D76	1	3	120
483125	D76	1	5	60
446270	D76	1	5	80
446271	D76	1	5	100
446272	D76	1	5	120
446273	D76	1	5	150



Part #	Model #	Tip	Thick (mm)	OAL (mm)
446274	D76	2	3	60
446275	D76	2	3	60
446276	D76	2	3	80
446277	D76	2	3	100
446278	D76	2	3	120
483131	D76	2	5	60
446279	D76	2	5	80
446280	D76	2	5	100
446281	D76	2	5	120
446282	D76	2	5	150



Part #	Model #	Tip	Thick (mm)	OAL (mm)
446284	D76	5	5	60
446285	D76	6	5	60
446286	D76	7	5	60
446287	D76	8H	5	60
446288	D76	10H	5	60
446289	D76	15H	5	60

\* H = Tamper Proof (see pg 37)

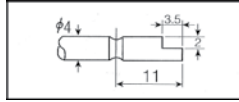

FOR USE WITH:  
DELVO (DENSEI)

## φ 4mm Drive



Part #	Model #	Tip	Shaft Dia. (mm)	OAL (mm)
446290	EPH201	0	1.8	44
446291	EPH202	0	1.8	64
446292	EPH203	00	2	44
446293	EPH204	00	2	64
446294	EPH205	0	2.5	44
446295	EPH206	0	2.5	64
446296	EPH207	1	3	44
446297	EPH208	1	3	64
446498	EPH209	1	4	44
446299	EPH210	1	4	64
446300	EPH211	2	4	44
446301	EPH212	2	4	64
446302	EPH213	3	6	44



Part #	Model #	Tip	Thick (mm)	OAL (mm)
446303	EPL221	2	0.3	44
446304	EPL222	2.5	0.3	44
446305	EPL223	3	0.4	44
446306	EPL224	4	0.5	44
446307	EPL225	5	0.65	44



Part #	Model #	Tip	Shaft Dia. (mm)	OAL (mm)
446308	EHW231	1.5	n/a	44
446309	EHW232	2	n/a	44
446310	EHW233	2.5	n/a	44
446311	EHW234	3	n/a	44



Part #	Model #	Size (mm)	Shaft Dia. (mm)	OAL (mm)
446312	EBX241	2.3	n/a	44
446313	EBX242	2.5	n/a	44
446314	EBX243	3	n/a	44
446315	EBX244	4	n/a	44
446316	EBX245	4.5	n/a	44
446317	EBX246	5	n/a	44
446318	EBX247	5.5	n/a	44



Part #	Model #	Tip	Thick (mm)	OAL (mm)
446319	ETX250	5	n/a	44
446320	ETX251	5	n/a	64
446321	ETX252	6	n/a	44
446322	ETX253	6	n/a	64
446323	ETX254	8H	n/a	44
446324	ETX255	8H	n/a	64
446325	ETX256	10H	n/a	44
446326	ETX257	10H	n/a	64
446327	ETX258	15H	n/a	44
446328	ETX259	15H	n/a	64

\* H = Tamper Proof (see pg 37)



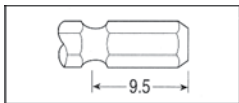

**1/4" = 6.35mm Drive**

**FOR USE WITH:** AEG, ARO, ATLAS-COPCO, BIAx, B&D, BOSCH, BUCKEYE-TOOLS, CHICAGO PNEUMATIC, CLECO, DELVO (DENSEI), DEPRAG, DESOUTTER, FIAM, FUJI-KUKI, GARDNER-DENVER, HIOS (FERRA TOOLS) HITACHI, INGERSOLL, KELLER, MAKITA, MALL, MATSUSHITA, METABO, NPK, PNEUTEC, PREMAG, ROCKWELL, ROTOR-TOOL, SKIL, STANLEY, STAR, STAYER, THOR, TONICHI, URYU, VAN-DORN, VIRAX, WOLF, YOKOTA, YUTANI



Part #	Model #	Tip	Shaft Dia. (mm)	OAL (mm)
446125	B35	00	1.2	40
446126	B35	00	1.2	60
446127	B35	00	1.5	40
446128	B35	00	1.5	60
446129	B35	00	1.7	40
446130	B35	00	1.7	60
446131	B35	00	2	40
446132	B35	00	2	60
446133	B35	00	2	80
446134	B35	00	2	60
446135	B35	00	2	80
446136	B35	00	2	60
446137	B35	00	2	80
446138	B35	00	2	100
446139	B35	00	2	60
446140	B35	00	2	80
446141	B35	00	2	100
446142	B35	0	1.4	40
446143	B35	0	1.4	60
446144	B35	0	1.4	80
446145	B35	0	1.4	60
446146	B35	0	1.4	80
446147	B35	0	1.4	100
446148	B35	0	1.7	40
446149	B35	0	1.7	60
446150	B35	0	1.7	60
446151	B35	0	1.7	80
446152	B35	0	2	40
446153	B35	0	2	60
446154	B35	0	2	80
446155	B35	0	2	100
446156	B35	0	2	80
446157	B35	0	2	100
446158	B35	0	2.5	40
446159	B35	0	2.5	60
446160	B35	0	2.5	80
446161	B35	0	2.5	100
446162	B35	0	2.5	80
446163	B35	0	2.5	100
446164	B35	0	3	40
446165	B35	0	3	60
446166	B35	0	3	80
446167	B35	0	3	100

Part #	Model #	Tip	Shaft Dia. (mm)	OAL (mm)
446168	B35	0	3	80
446169	B35	0	3	100
446170	B35	0	4	40
446171	B35	0	4	60
446172	B35	1	2.2	40
446173	B35	1	2.2	60
446174	B35	1	2.3	75
446175	B35	1	2.5	40
446176	B35	1	2.5	60
446177	B35	1	2.5	60
446178	B35	1	2.5	80
446179	B35	1	2.5	100
446180	B35	1	3	40
446181	B35	1	3	60
446182	B35	1	3	80
446183	B35	1	3	100
446184	B35	1	3	60
446185	B35	1	3	80
446186	B35	1	3	100
446187	B35	1	3.2	75
446188	B35	1	4	40
446189	B35	1	4	60
446190	B35	1	4	80
446191	B35	1	4	100
424035	B35	1	7	75
446192	B35	1	4	120
446193	B35	2	3	40
446194	B35	2	3	60
446195	B35	2	3	80
446196	B35	2	3	60
446197	B35	2	3.2	70
446198	B35	2	3	80
446199	B35	2	3	100
446200	B35	2	3	120
446201	B35	2	3.2	75
446202	B35	2	4	40
446203	B35	2	4	60
446204	B35	2	4	80
446205	B35	2	4	100
446206	B35	2	4	120
424049	B35	2	7	150
446207	B35	2	7	200



Part #	Model #	Tip Size	Shaft Dia. (in)	OAL (mm)
446423	10600	00	2/32"	49
487195	1060	0	1/8"	49
487200	1061	1	3/16"	49
446424	1062R	2	3/16"	49
487205	1062	2	1/4"	49
487201	1071	1	3/16"	70
487206	1072	2	1/4"	70
487202	1081	1	3/16"	89
487207	1082	2	1/4"	89
446425	41071	1	3/16"	75
446426	42071	2	3/16"	75
446427	41081	1	3/16"	100



Part #	Model #	A/F (mm)	Shaft Dia. (in)	OAL (mm)
489301	1304/50	4	8	50
489302	1345/50	4.5	8	50
489303	1305/50	5	8.5	50
489304	1355/50	5.5	9	50
489305	1306/50	6	10	50
489306	1307/50	7	13	50
489307	1308/50	8	13	50
489308	1309/50	9	14	50
489309	1310/50	10	16	50
489310	1311/50	11	17	50
489311	1312/50	12	19	50
489312	1313/50	13	19	50
489313	1314/50	14	20	50
446601	1317/55	17		55

\* Other lengths available up to 150 mm.

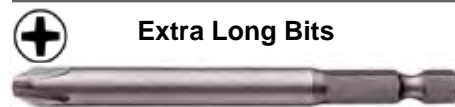

**Extra Long Bits**

Part #	Model #	Tip Size	Shaft Dia. (mm)	OAL (mm)
489672	4301/150	1	4.5	150
489673	4302/150	2	6	150
446437	4303/150	3	8	150
446438	4301/200	1	4.5	200
446439	4302/200	2	6	200
446440	4303/200	3	8	150

**FOR USE WITH:** AEG, ARO, ATLAS-COPCO, BIAx, B&D, BOSCH, BUCKEY-TOOLS, CHICAGO PNEUMATIC, CLECO, DELVO (DENSEI), DEPRAG, DESOUTTER, FIAM, FUJI-KUKI, GARDNER-DENVER, HIOS (FERRA TOOLS) HITACHI, INGERSOLL, KELLER, MAKITA, MALL, MATSUSHITA, METABO, NPK, PNEUTEC, PREMAG, ROCKWELL, ROTOR-TOOL, SKIL, STANLEY, STAR, STAYER, THOR, TONICHI, URYU, VAN-DORN, VIRAX, WOLF, YOKOTA, YUTANI

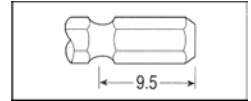

**1/4" = 6.35mm Drive**



Part #	Model #	Tip Size	Shaft Dia. (mm)	OAL (mm)
21202	-	2	3	49
487280	21225	2.5	3.5	49
487281	21203	3	3.5	49
487282	21204	4	4.6	49
487283	21205	5	5.8	49
487284	21206	6		49
489291	1332/70	2	7	70
489292	1333/70	3	7	70
489293	1334/70	4	7	70
489294	1335/70	5	7	70
489295	1336/70	6	7	70
489496	1337/70	7	10	70
489297	1338/70	8	11	70
489298	1339/70	9	11	70
489299	1334/70	10	12	70
424080	B35	2	7	75
424082	B35	2.5	7	75
424084	B35	3	7	75
424086	B35	4	7	75
424088	B35	5	7	75
424090	B35	6	7	75
424081	B35	2	7	100
424083	B35	2.5	7	100
424085	B35	3	7	100
424087	B35	4	7	100
424089	B35	5	7	100
424091	B35	6	7	100



Part #	Model #	Width (mm)	Thick (mm)	OAL (mm)
489271	5303/51	3	0.5	51
489272	5335/51	3.5	0.55	51
489273	5304/51	4	0.6	51
489274	5345/51	4.5	0.7	51
489275	5305/51	5	0.75	51
489276	5355/51	5.5	0.8	51
489277	5306/51	6	0.85	51
449278	5365/51	6.5	0.85	51
489279	5307/51	7	0.9	51
489280	5308/51	8	1	51
489281	5309/51	9	1.15	51
489282	5310/51	10	1.2	51
489675	5303/75	3	0.5	75
489283	5304/75	4	0.6	75
489284	5305/75	5	0.75	75
489285	5306/75	6	0.85	75
489676	5306/125	6	0.85	125
489677	5365/75	6.5	0.85	75
489286	5307/75	7	0.9	75



Part #	Model #	Tip Size	Shaft Dia. (mm)	OAL (mm)
446488	T10607	7	N/A	49
446489	T10608	8	N/A	49
446490	T10609	9	N/A	49
446491	T10610	10	N/A	49
446492	T10615	15	N/A	49
446493	T10620	20	N/A	49
446494	T10625	25	N/A	49
446495	T10627	27	N/A	49
446496	T10630	30	N/A	49
446497	T10640	40	N/A	49
446499	T10707	7	N/A	70
446500	T10708	8	N/A	70
446501	T10709	9	N/A	70
446502	T10710	10	N/A	70
466503	T10715	15	N/A	70
466504	T10720	20	N/A	70
466505	T10725	25	N/A	70
466506	T10727	27	N/A	70
466507	T10730	30	N/A	70
466508	T10740	40	N/A	70
446509	T10807	7	N/A	90
446510	T10808	8	N/A	90
466511	T10809	9	N/A	90
466512	T10810	10	N/A	90
466513	T10815	15	N/A	90
466514	T10820	20	N/A	90
466515	T10825	25	N/A	90
466516	T10827	27	N/A	90
466517	T10830	30	N/A	90
446518	T10840	40	N/A	90

**NOTE: Tamper Proof Models Available**



Part No.	Model #	Tip	OAL (mm)
487300	3031	1	49
487305	3032	2	49
487310	3033	3	49
487301	3041	1	70
487306	3042	2	70
487311	3043	3	70
487302	3051	1	90
487307	3052	2	90
487312	3053	3	90
487303	3061	1	152
487308	3062	2	152
487313	3063	3	152



Part #	Model #	Tip Size	Shaft Dia. (mm)	OAL (mm)
635300	JT	6	4	75
635305	JT	8	4.5	75
635310	JT	10	4.5	75
635315	JT	15	4.5	75
635320	JT	20	5	75
635325	JT	25	5	75
635330	JT	27	5.5	75
635335	JT	30	6	75
635340	JT	40	7	75
635345	JT	45	8	75
635301	JT	6	4	100
635306	JT	8	4.5	100
635311	JT	10	4.5	100
635316	JT	15	4.5	100
635321	JT	20	5	100
635326	JT	25	5	100
635331	JT	27	5.5	100
635336	JT	30	6	100
635341	JT	40	7	100
635346	JT	45	8	100



Part No.	Model #	Tip	Shaft Dia. (mm)	OAL (mm)
487270	2021	7/64	-	49
487271	2022	1/8	-	49
487272	2023	9/64	-	49
487273	2024	5/32	-	49
487274	2025	3/16	-	49
487275	2026	7/32	-	49
487276	2027	1/4	-	49

# Industrial Bits



FOR USE WITH: VESSEL, HITACHI, MAKITA, MATSUSHITA, MAX, NPK, RYOBI, TONICHI, TOSHIBA, YOKOTA, YUTANI



Part No.	Model #	Tip	Shaft Dia. (mm)	OAL (mm)
481090	A16	2	-	65
481091	A16	2.5	-	65
481092	A16	3	-	65
481093	A16	4	-	65
481094	A16	5	-	65
481096	A16	6	-	65



Part #	Model #	Width (mm)	Thick (mm)	OAL (mm)
415071	A16	6	0.8	45
415072	A16	6	0.8	70
415171	A16	8	1	45
415172	A16	8	1	70
415271	A16	10	1.2	45
415272	A16	10	1.2	70

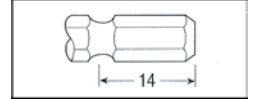

1/4" = 6.35mm Drive



Part #	Model #	Tip Size	OAL (mm)
413029	A14	1	45
413031	A14	1	65
413032	A14	1	65
413231	A14	1	110
413039	A14	2	45
413041	A14	2	45
413040	A14	2	45
413047	A14	2	65
413042	A14	2	65
413043	A14	2	65
413045	A14	2	65
413241	A14	2	110
413242	A14	2	110
413243	A14	2	110
413245	A14	2	150
413247	A14	2	150
413249	A14	2	200
413255	A14	2	300
413051	A14	3	45
413052	A14	3	65
413252	A14	3	110
413251	A14	3	110



Part No.	Model #	Tip	Shaft Dia. (mm)	OAL (mm)
635120	VT	10	4.5	65
635125	VT	15	4.5	65
635130	VT	20	5	65
635135	VT	25	5	65
635140	VT	27	5.5	65
635145	VT	30	6	65
635150	VT	40	7	65
635121	VT	10	4.5	110
635126	VT	15	4.5	110
635131	VT	20	5	110
635136	VT	25	5	110
635141	VT	27	5.5	110
635146	VT	30	6	110
635151	VT	40	7	110



Part #	Model #	A/F (mm)	Shaft Dia. (in)	OAL (mm)
416080	A20	4.5	7.5	55
416081	A20	5	8.5	55
416082	A20	5.5	10	55
416083	A20	6	10	55
416084	A20	7	13	55
416181	A20	8	13	55
416182	A20	9	16	55
416188	A20	9.6	16	55
416183	A20	10	16	55
416184	A20	11	16	55
416185	A20	12	19	55
416186	A20	13	19	55
416187	A20	14	20	55
416189	A20	15	22	55
416190	A20	17	23	55

\* Other lengths available up to 100 mm.

FOR USE WITH: DELVO (DENSEI), HIOS (FERRA TOOLS), HITACHI, MATSUSHITA, URYU, YOKOTA



Part No.	Model #	Tip	Shaft Dia. (mm)	OAL (mm)
422036	B34	1	6	70
422031	B34	1	6	72
422037	B34	1	6	100
422032	B34	1	6	100
422038	B34	1	6	150
422033	B34	1	6	150
422051	B34	2	6	70
422041	B34	2	6	70
422052	B34	2	6	100
422042	B34	2	6	100
422053	B34	2	6	120
422045	B34	2	6	120
422067	B34	2	6	125
422068	B34	2	6	125
422054	B34	2	6	150

Part No.	Model #	Tip	Shaft Dia. (mm)	OAL (mm)
422043	B34	2	6	150
422055	B34	2	6	200
422044	B34	2	6	200
422039	B34	1	5.3	105
422034	B34	1	5.3	105
422040	B34	1	5.3	120
422035	B34	1	5.3	120
422061	B34	1	5.3	125
422062	B34	1	5.3	125
422058	B34	2	5.3	105
422046	B34	2	5.3	105
422059	B34	2	5.3	120
422047	B34	2	5.3	120
422064	B34	2	5.3	125
422065	B34	2	5.3	125

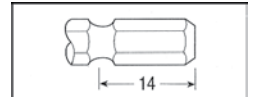

5mm Drive



Part #	Model #	Tip Size	OAL (mm)
423035	B36	1	70
423031	B36	1	70
423036	B36	1	100
423032	B36	1	100
423045	B36	2	70
423041	B36	2	70
423046	B36	2	100
423042	B36	2	100
423047	B36	2	100
423043	B36	2	100



JDV Products, Inc • 22-01 Raphael Street • Fair Lawn, NJ 07410 USA  
201-796-1720 • Fax 201-796-9399 • www.jdvproducts.com

## GT-S4.5DR



Bit Sleeve Retainer  
**6.35mm**

Noise reducer

## GT-PLR



Ball Spring Retainer  
**6.35mm**

Lever activated

## GT-PLP



Ball Spring Retainer  
**6.35mm**

Button activated  
Rear exhaust

## GT-PLZ



Bit Sleeve Retainer  
**6.35mm** (pull type)

Lever activated  
Noise Reducer

## GT-PLRC



Angle Head Size

Ball Spring Retainer  
**6.35mm**

Lever activated

## GT-H2



Guide Spring Retainer  
**3mm**

Push activated  
Rear exhaust

## GT-H4R



Ball Spring Retainer  
**6.35mm**

Lever activated  
Noise Reducer

### Options

Anvil for A/F 5mm bit  
Torque Adjusting Spring  
(medium/weak)

## GT-P4.5D GT-P4.5DR (powerful for reverse turn)



Bit Sleeve Retainer  
**6.35mm**

Trigger activated  
Noise reducer  
Rear exhaust

## GT-P5LS



Bit Sleeve Retainer  
**6.35mm** (pull type)

Trigger activated  
Noise reducer  
Rear exhaust



The Pursuit of Quality

For Industrial Bits,  
please see page 46

## GT-PH4



Ball Spring Retainer  
**5mm**

Trigger activated  
Noise reducer  
Rear exhaust

### Options

Torque Spring  
Anvil for A/F 6.35mm bit

## GT-PH5



Ball Spring Retainer  
**6.35mm**

Trigger activated  
Noise reducer  
Rear exhaust

Part No.	Capacity (mm)				Torque Range		Free Speed (rpm)	Air Cons. m3/min	Hose Coupling	O.A.L.		Weight	
	Standard Screw	Tapping Screw	Wooden Screw	Bolt	N.m.	(ft. lbf)				mm	in.	g.	lb.
GT-S4.5DR	4.0 ~ 5.0	3.5 ~ 4.0	2.7 ~ 3.5	4.0 ~ 5.0	3.4 ~ 6.4	(2.5 ~ 4.7)	14,000	0.2	G 1/4	180	7-3/32	585	1.29
GT-PLR	4.0 ~ 5.0	-	2.7 ~ 3.5	4.0 ~ 5.0	2.9 ~ 6.9	(2.2 ~ 5.1)	9,000	0.2	G 1/4	187	7-11/32	830	1.83
GT-PLP	4.0 ~ 5.0	3.5 ~ 4.0	2.7 ~ 3.5	4.0 ~ 5.0	3.4 ~ 6.4	(2.5 ~ 4.7)	9,000	0.2	G 1/4	197	7-3/4	750	1.65
GT-PLZ	4.0 ~ 5.0	3.5 ~ 4.0	2.7 ~ 3.5	4.0 ~ 5.0	2.9 ~ 6.9	(2.2 ~ 5.1)	9,000	0.2	G 1/4	205	8-5/64	950	2.09
GT-PLRC	4.0 ~ 5.0	-	-	4.0 ~ 5.0	2.0 ~ 5.9	(1.5 ~ 4.3)	9,000	0.2	G 1/4	228	8-31/32	1,100	2.43
GT-H2	1.6 ~ 2.3	-	-	-	0.1 ~ 0.4	(0.1 ~ 0.3)	3,200	0.16	G 1/4	164	6-7/16	267	0.59
GT-H4R	3 ~ 4	-	1.8 ~ 2.4	3 ~ 4	1.0 ~ 2.2	(0.7 ~ 1.6)	1,500	0.2	G 1/4	190	7-15/32	590	1.30
GT-P4.5D	4.0 ~ 5.0	3.5 ~ 4.0	2.7 ~ 3.5	4.0 ~ 5.0	3.4 ~ 6.4	(2.5 ~ 4.7)	14,000	0.2	Rc 1/4	160	6-9/32	715	1.58
GT-P5LS	4.0 ~ 5.0	3.5 ~ 4.0	2.7 ~ 3.5	4.0 ~ 5.0	2.9 ~ 6.9	(2.2 ~ 5.1)	9,000	0.2	Rc 1/4	165	6-1/2	980	2.16
GT-PH4	3 ~ 4	-	1.8 ~ 2.4	3 ~ 4	1.0 ~ 2.2	(0.8 ~ 1.6)	1,500	0.19	Rc 1/4	175	6-7/8	800	1.76
GT-PH5	4 ~ 5	3.5 ~ 4	2.7 ~ 3.5	4 ~ 5	2.0 ~ 5.4	(1.5 ~ 4.0)	1,500	0.25	Rc 1/4	200	7-7/8	1,070	2.36

• Air pressure... 0.6 Mpa • Air hose bore diameter: 6.35 mm • OAL does not include accessories and hangers • Weight: Accessories not included



JDV Products, Inc • 22-01 Raphael Street • Fair Lawn, NJ 07410 USA  
201-796-1720 • Fax 201-796-9399 • www.jdvproducts.com

# Pneumatic Screwdrivers



## GT-P6XD



Bit Sleeve Retainer  
5~6mm

Trigger activated  
Noise reducer  
Rear exhaust

## GT-P6LS III



Bit Sleeve Retainer  
6.35mm

Trigger activated  
Noise reducer  
Rear exhaust

Options  
Anvil  
(9mm bit insertion length)  
(push type bit insertion)

## GT-P6HS



Bit Sleeve Retainer  
6.35mm

Trigger activated  
Noise reducer  
Rear exhaust

Part No.	Torque Range		Free Speed (rpm)	Air Cons. m3/min	O.A.L.		Weight		Air Hose Size	Body Form
	N.m.	(ft. lbf)			mm	in.	kg.	lb.		
GT-P6XD	-	-	8500	0.49	153	6 3/16	940	2.07	PT 1/4	PISTOL
GT-P6LS III	3.9 ~ 9.8	2.9 ~ 7.2	9000	0.3	177	6 31/32	955	2.11	PT 1/4	PISTOL
GT-P6HS	7.9 ~ 19.6	5.8 ~ 14.5	10000	0.3	180	7 3/32	1170	2.58	PT 1/4	PISTOL

• Air pressure... 0.6 Mpa • Air hose bore diameter: 6.35 mm • OAL does not include accessories and hangers • Weight: Accessories not included

# Pneumatic Impact Wrenches

## GT-3800PF



Square Drive Size  
25.4mm

Pin Lock

## GT-3800LF

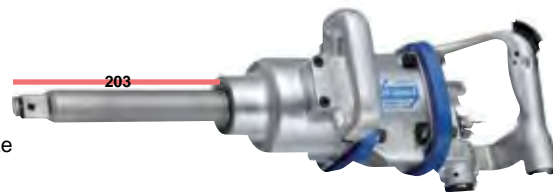

Square Drive Size  
25.4mm

Pin Lock

## GT-4200PF



Square Drive Size  
25.4mm

Pin Lock

## GT-4200LF

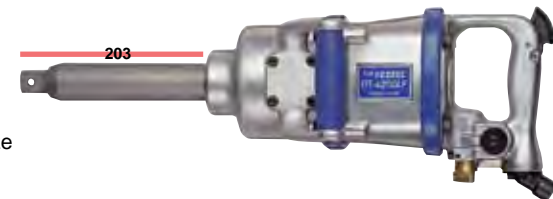

Square Drive Size  
25.4mm

Pin Lock

## GT-S55R



Square Drive Size  
25.4mm

Pin Lock  
Noise Reducer

Part No.	Torque Range		Free Speed (rpm)	Air Cons. m3/min	O.A.L.		Weight		Air Hose Size	Body Form
	N.m.	(ft. lbf)			mm	in.	kg.	lb.		
GT-3800PF	343 ~ 1569	253 ~ 1157	3800	0.8	251	9 7/8	9.2	20.28	PT 3/8	PISTOL
GT-3800LF	343 ~ 1569	253 ~ 1157	4000	0.8	518	20 3/8	9.5	20.94	PT 3/8	STRAIGHT
GT-4200PF	490 ~ 1765	361 ~ 1302	2500	1.0	296	11 21/32	11.5	25.35	PT 3/8	PISTOL
GT-4200LF	490 ~ 1765	361 ~ 1302	3200	1.0	559	22 1/64	13.3	29.32	PT 3/8	STRAIGHT
GT-S55R	490 ~ 2450	361 ~ 1807	2800	1.2	610	24 1/64	17.0	37.48	PT 1/2	STRAIGHT

• Air pressure... 0.6 Mpa • Air hose bore diameter: 6.35 mm • OAL does not include accessories and hangers • Weight: Accessories not included



JDV Products, Inc • 22-01 Raphael Street • Fair Lawn, NJ 07410 USA  
201-796-1720 • Fax 201-796-9399 • www.jdvproducts.com

## GT-S650



Square Drive Size  
**9.5mm**

Retainer Ring

## GT-P6 II



Square Drive Size  
**9.5mm**

Retainer Ring

Options  
GT-P6 II Z  
(with noise reducer)

## GT-S600C



Square Drive Size  
**9.5mm**

Ball Lock

## GT-P8 II



Square Drive Size  
**12.7mm**

Retainer Ring

Options  
GT-P8 II Z  
(with noise reducer)

## GT-P12



Square Drive Size  
**12.7mm**

Retainer Ring

Options  
GT-P12 Z  
(with noise reducer)

## GT-P14J



Square Drive Size  
**12.7mm**

Retainer Ring

Options  
GT-P14JZ  
(with noise reducer)

## GT-P14JL



Square Drive Size  
**12.7mm**

Retainer Ring

## GT-P18J



Square Drive Size  
**19mm**

Retainer Ring

Options  
GT-P18JZ  
(with noise reducer)

## GT-P18JL

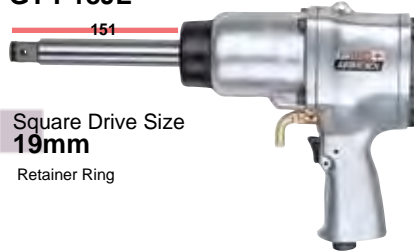

Square Drive Size  
**19mm**

Retainer Ring

## GT-P32J



Square Drive Size  
**25.4mm**

Pin Lock



Part No.	Torque Range		Free Speed (rpm)	Air Cons. m3/min	O.A.L.		Weight		Air Hose Size	Body Form
	N.m.	(ft. lbf)			mm	in.	kg.	lb.		
GT-S650	20 ~ 69	15 ~ 51	7500	0.30	207	8 5/32	1.33	2.93	PT 1/4	STRAIGHT
GT-P6 II	20 ~ 69	15 ~ 51	7800	0.38	146	5 3/4	1.43	3.15	PT 1/4	PISTOL
GT-S600C	20 ~ 39	15 ~ 29	5600	0.30	250	9 27/32	1.87	4.12	PT 1/4	ANGLE
GT-P8 II	39 ~ 137	29 ~ 101	7500	0.40	163	6 3/8	1.89	4.17	PT 1/4	PISTOL
GT-P12	69 ~ 216	51 ~ 159	7500	0.40	183	7 3/16	2.30	5.07	PT 1/4	PISTOL
GT-P14J	98 ~ 265	72 ~ 195	6300	0.42	194	7 5/8	2.95	6.50	PT 1/4	PISTOL
GT-P14JL	98 ~ 265	72 ~ 195	6300	0.42	226	8 7/8	3.05	6.72	PT 1/4	PISTOL
GT-P18J	196 ~ 461	145 ~ 340	5000	0.52	239	9 3/8	4.20	9.26	PT 1/4	PISTOL
GT-P18JL	196 ~ 461	145 ~ 461	4700	0.52	353	13 7/8	4.70	10.36	PT 1/4	PISTOL
GT-P32J	343 ~ 1275	253 ~ 940	4200	1.30	264	10 3/8	11.2	24.70	PT 1/4	PISTOL

• Air pressure... 0.6 Mpa • Air hose bore diameter: 6.35 mm • OAL does not include accessories and hangers • Weight: Accessories not included



JDV Products, Inc • 22-01 Raphael Street • Fair Lawn, NJ 07410 USA  
201-796-1720 • Fax 201-796-9399 • www.jdvproducts.com

**Pneumatic Scraper**



**GT-ASC5**  
Blade sold separately

Perfect for removing IC chips from circuit boards when recycling PCs, faxe machines and copiers, This tool is also ideal for the removal of stickers, and can even scrape off mortar or paint from external walls of buildings. The short stroke pitch reduces jumping of the scraper attachment, whereby making it more comfortable for the operator.

Part No.	Working Air Pressure MPa	Stroke Speed c.p.m.	Air Consumption m3/min	Stroke (mm)	Air Hose Joint	O.A.L.		Weight
						mm	g.	
GT-ASC5	0.6	7,000	0.28	5	RFC1/4	195.5	810	

Part No.	Blade Width	Shank Dia.	Used for
ASC-25-8	25 mm	8	IC chip
ASC-50-8	50 mm	8	IC chip, out wall



**Pneumatic Saws**



**GT-AS10**

- Oil-resistant cushion grip
- Convenient RESET button can be used to restart unit if engine stalls
- Noise reducer

**FEEL THE DIFFERENCE**



**GT-AS100**

- High-speed cutting
- Ergonomic rubber grip
- Ideal for long-use applications
- Very lightweight

Part No.	Cutting Capacity	Working Air Pressure MPa	Stroke Speed c.p.m.	Air Consumption m3/min	Stroke (mm)	Air Hose Joint	O.A.L.		Weight
							mm	g.	
GT-AS10	Steel: 4mm	0.6	5,000	0.28	10	Rc 1/4	195.5	570	
GT-AS100	Steel: 1.6mm Wood: 55mm	0.6	10,000	0.34	10	Rc 1/4	170	570	

Part No.	Specifications	Part No.	Specifications
ASB-32	Cobalt mix Std. blade, 32 teeth	ASB-25-5	25mm wide scraper blade
ASB-32T	Thin blade, 32 teeth	ASF-F-5	Flat file
ASB-32H	Cobalt mix Thick blade, 32 teeth	ASF-R-5	Round file
ASB-24H	Cobalt mix Thick blade, 24 teeth	ASF-T-5	Triangular file



**Blow Guns**

**NEW!**



**AD-3-100A**

VESSEL's "Air Penguin" series blow guns are equipped with an ergonomically designed handle and trigger, a safety nozzle, and are very lightweight. The AD-3-100A comes with a stainless steel nozzle angled at 30° to access hard to reach places.



**AD-3-S**

Part No.	Max Working Pressure	Working Temperature	O.A.L.		Weight		Inlet
			mm.	in.	g.	lb.	
AD-3-S	0.97MPa	0°C - 60°C	148	5.83	71	0.16	Rc 1/4
AD-3-100A	0.97MPa	0°C - 60°C	217	8.54	83	0.18	Rc 1/4

Increase productivity with our lightweight pneumatic cutting tools. Ideal for cutting wire, terminals, or for trimming component leads on thru-hole PCB's.

The cutting blades can be easily rotated for left or right-handed operation in less than a minute and the unit is easily maintained.

Replacing manual cutting tools with these ergonomic air-powered units can reduce injuries caused by Repetitive Stress Syndrome. Each kit includes the air nipper body, cutting blade, 6 ft. air hose, and fittings.

Additional size units and body styles available.



"BBH" Blade



"AS" Blade



"HS" Blade



Kit Part No.	Cutting Capacity (mm)			Supply Air Pressure (psi)	Body Dia. (mm)	Weight (g)	Overall Length (mm)	Replacement Blade Part No.
	Copper	Steel	Piano Wire					
GT-N3/BBH	1.0	0.5	0.2	58-73	23	95	112	N3BBH90
GT-N3/AS								N3AS
GT-N3/HS								N3HS
GT-N7/BBH	1.6	1.0	0.5	58-73	34	180	123	N7BBH80
GT-N7/AS								N7AS
GT-N7/HS								N7HS
GT-N20/BBH	2.6	2.0	1.0	73-87	45	375	156	N20BBH837
GT-N20/AS								N20AS
GT-N20/HS								N20HS

\* Cutting capacities are based on ideal conditions. Weight and OAL does not include blades or accessories. 1/8" or 1/4" NPT male fittings provided.

**Elbow Fitting**



Part No.	Hose OD	Thread	Part No.	Hose OD	Thread
ELB4-8	4MM	R1/8	ELB1/4-8M	1/4"	R1/8
ELB4-4	4MM	R1/4	ELB1/4-4M	1/4"	R1/4
ELB6-8	6MM	R1/8	ELB1/4-8	1/4"	1/8" NPT
ELB6-4	6MM	R1/4			

**Straight Fitting**



Part No.	Hose OD	Thread	Part No.	Hose OD	Thread
SF4-8	4MM	R1/8	SF1/4-8M	1/4"	R1/8
SF4-4	4MM	R1/4	SF1/4-4M	1/4"	R1/4
SF6-8	6MM	R1/8	SF1/4-8	1/4"	1/8" NPT
SF6-4	6MM	R1/4			

**Coiled Hose**



Part No.	Hose OD	Hose ID
CH1/4	1/4"	1/8"
Extended Length: 8' Retracted Length: 6.5'		

**Nylon Hose**



Part No.	Fitting	Length
A-10738	1/8"	6'
A-12549	1/8"	8'

**Kink Resistant Hose**



Part No.	Hose OD	Hose ID
H4	4mm	2.4mm
H6	6mm	4mm
H1/4	1/4"	0.160"

Most pneumatic tool manufacturers recommend using a filter regulator. The filter/regulator removes particles and captures moisture, while the regulator is used when the air is clean and dry. Both come equipped with a gauge.

**REG**



**FILREG**



**RMB**



Will fit both REG regulator and FILREG Filer Regulator

Part No.	Port Size (NPT)	Pressure Range	Max. Operating Pressure	Filtration
REG	1/8"	7-120 psi	150 psi	5µm
FILREG	1/8"	7-120 psi	150 psi	NONE





- Prevents Ergonomic Health Issues
- Universal Crimping Jaw
- Variety of Die Sets (10-22AWG)



The TH-2000 starter kit includes a tool stand with foot pedal, VESSEL high-quality air nipper body, hose, and fittings. The swiveling stand can be easily fastened to a surface for quick, precise, and safe crimping.

**NOTE:** Crimping Jaw and Die Set are not included with TH-2000. Please see Crimping Jaw and Die Set Options.

TH-2000 Pneumatic Crimper includes:

Part No.	Description
GT-NR30	Round Air Nipper Body
NR30ST	Swivel Air Nipper Stand
250F-3-10	Foot Pedal Actuator
A-10738	6 ft. Nylon Braided Air Hose

Optional model P-30 power booster available

**SIMPLE TO OPERATE!  
AS EASY AS...**

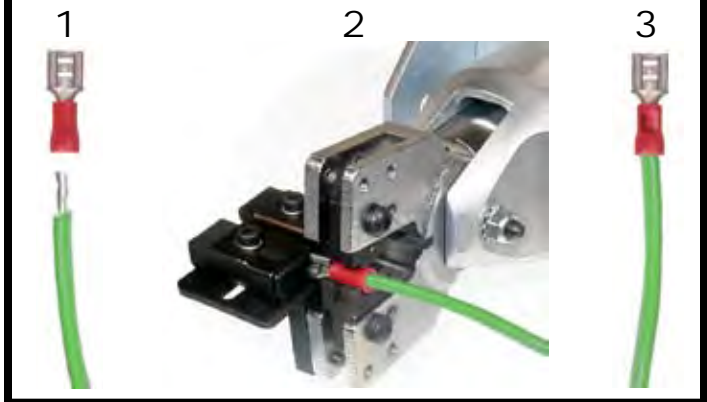

## Crimping Jaws & Die Sets

### NON-INSULATED Terminals

Part No.	Description	AWG
CJ-NT125	Crimping Jaw	22-16
NT125	Replacement Die Set	
CJ-NT200	Crimping Jaw	16-12
NT200	Replacement Die Set	
CJ-NT500	Crimping Jaw	12-10
NT500	Replacement Die Set	

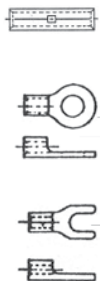

### INSULATED Terminals

Part No.	Description	AWG
CJ-IT125	Crimping Jaw	22-16
IT125	Replacement Die Set	
CJ-IT200	Crimping Jaw	16-12
IT200	Replacement Die Set	
CJ-IT500	Crimping Jaw	12-10
IT500	Replacement Die Set	



### CLOSED-END INSULATED Connectors

Part No.	Description	AWG
CJ-CE125	Crimping Jaw	22-16
CE125	Replacement Die Set	
CJ-CE200	Crimping Jaw	16-12
CE200	Replacement Die Set	
CJ-CE500	Crimping Jaw	12-10
CE500	Replacement Die Set	
A-13465	Positioning Device	



Static electricity causes contamination by dirt or dust. It is generated in molding where strong compression or friction occurs, causing airborne dirt or dust to adhere to the work the moment it is removed from the mold.

Immediate Static Elimination right after items are removed from an injection mold.

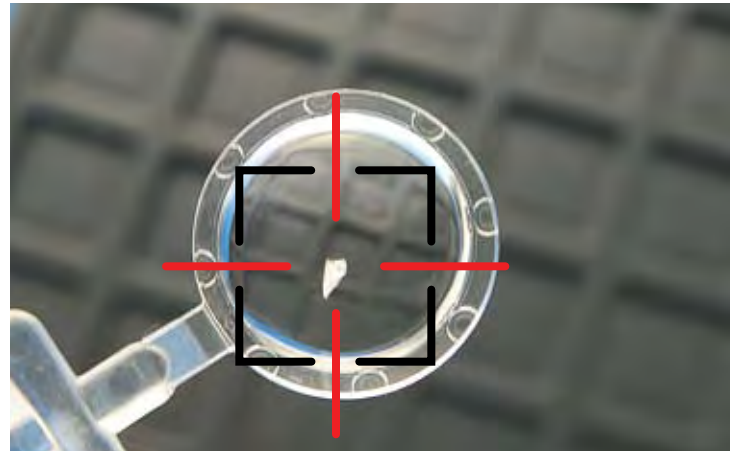

The SDJ-02R is a small, lightweight and handy static electricity eraser that can be installed directly on the chuck plate of the extractor. When the extractor takes a part from the mold and hands it to the conveyor line, the chuck plate holds the work while the SDJ-02R blows ionized air on it, which effectively removes static electricity.



Static electricity can be removed continuously or intermittently during work holding and handling as demanded by the charged condition of the work.

This kind of control normally requires a sequencer or solenoid valve built into the extractor, plus air supply and electric power.

### Features:

- Super-small and lightweight, the entire unit can be installed on moving part of a robot or the innermost space of an automated machine.
- Designed for safety with built-in discharge parts, high-voltage cable, and high-voltage build-up parts.
- Used 24V DC power supply for safety.
- Can effectively use the molding cycle when installed on the chuck plate of the extractor.
- Products of stable quality can be manufactured by keeping dust and dirt away.
- Easy one-touch replacement of the electrode wire unit.

### Application:

Applicable for dust and chip removal from molds and products, static elimination off injection mold, dust-off, improving removal from mold, to assemble with anti-static cleaning and installing into automation machine.

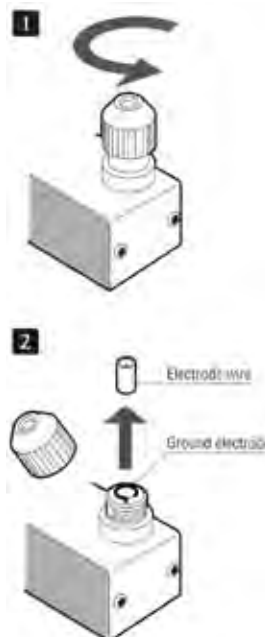

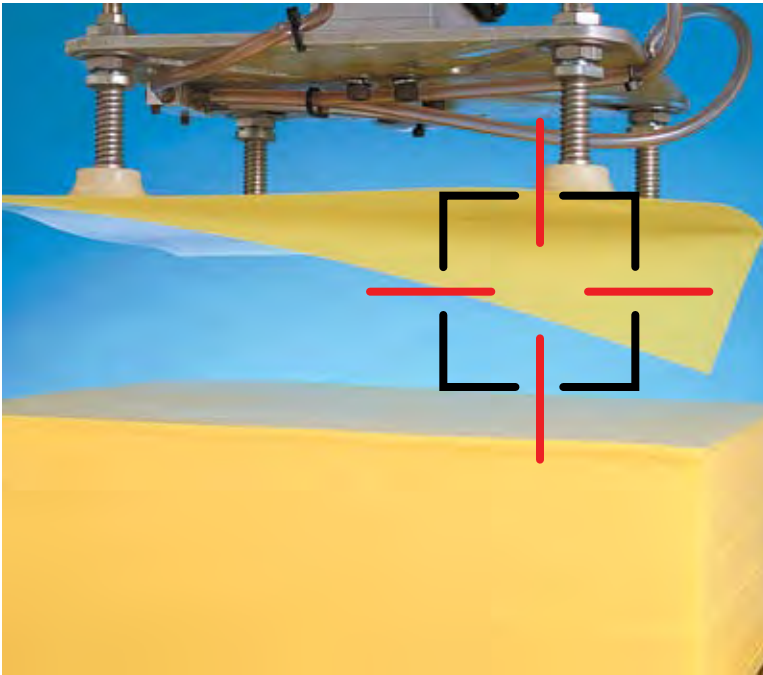

During work handling, the film insert laminate is repeatedly contacted and detached by the pickup, causing electrical charge to accumulate on the film.

Pin-pointed Ion blow for effective static-elimination.

With a flared nozzle, the SDJ-03R can blow ionized air across a wide area. Small and lightweight, the entire unit can be installed near a stocker, grinder, parts feeder, or mold to securely remove static electricity from targeted points. In addition, the SDJ-03R is equipped with height-adjustable fittings and the nozzle can be angled as needed. Therefore, air blow can be easily fine-tuned to contact a specific area.



### Features:

- The flared nozzle can blow across a wide area.
- Designed for safety with built-in discharge parts, high-voltage cable, and high-voltage build-up parts.
- Uses a 24V DC power supply for safety.
- Products of stable quality can be manufactured by keeping dust and dirt away.
- Easy one-touch replacement of the electrode wire unit.

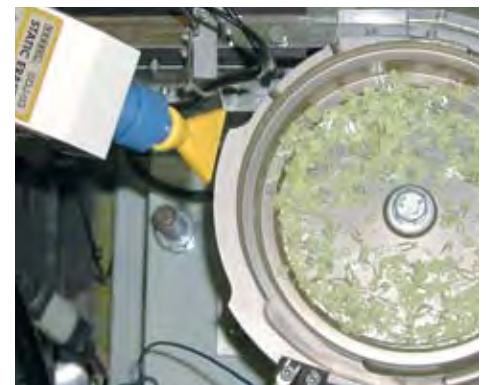
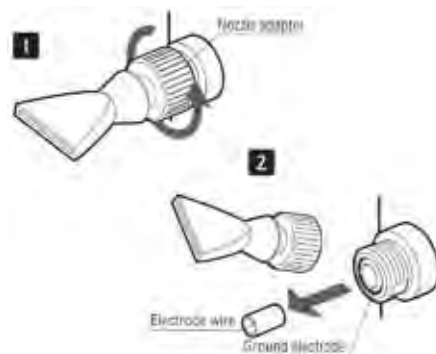

### Application:

Elimination of static charge of resin pellets, inside of hopper containers, stocker and molded parts, plastic crushers, stacked film, IC printcard, Lens assembly lines, vaporized and Fore-process, accumulation in parts feeders, and other static troubles.

Uneven colors often occur in coating processes of metallic or pearl-finish surfaces. The reason is that the aluminum flake or pearl mica in the paint is dispersed by static electricity during the coating process. Resultantly, the surface is not consistent or fine.

The SDJ-06R can be used against a wide range of static electricity trouble such as prevention of dust accumulation of items, removal of electric charge and dust from trays, clear dust from molds, or removal of dust before coating. Dirt can be removed by elimination static electricity and dust before shipping. The SDJ-06R is a gun-type static electricity eraser with a flared nozzle that can remove static and dust over a wide area.

Static electricity is generated in molding where strong compression or friction occurs. Then, the moment the mold cools and the work is removed, electricity discharges between the work and molding. The work is charged by this discharge, and if the work is left for a while under this condition, airborne dust will accumulate in an electrified pattern resembling lightning or discs.

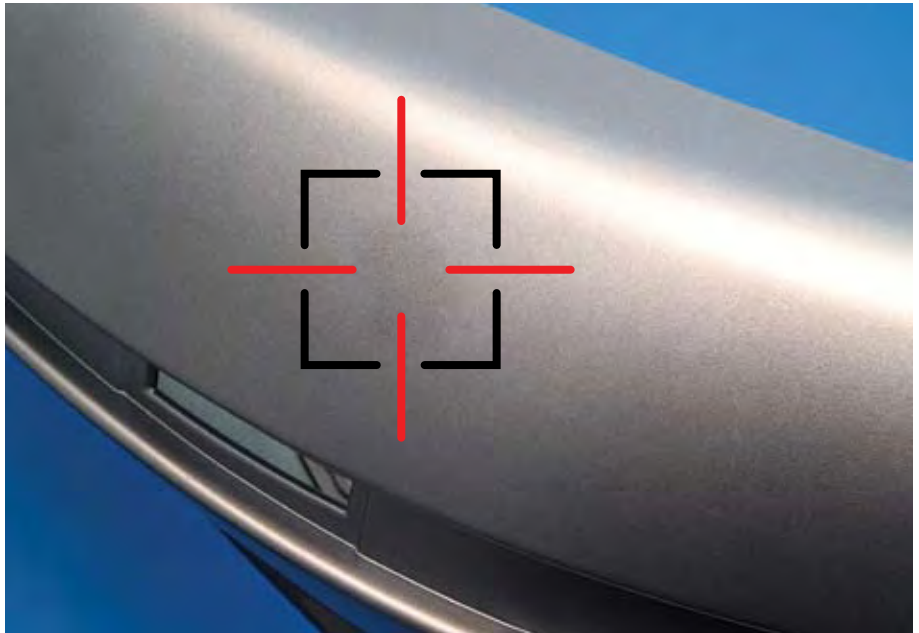

Practice static elimination and dust removal before shipping.

### Features:

- The small and lightweight body incorporates a high-voltage section, which eliminates high-voltage cables and ensures safety.
- Ergonomic grip fits comfortably in user's hand.
- Uses a 4V DC power supply for safety.
- The air hose and electrical wires are concealed by a flexible duct.
- Easy one-touch replacement of the electrode wire unit.

### Application:

Dust and chip removal from molds and products, pellets, paper and film. Static removal and dust countermeasure for acceptance and assembly of LCDs, ICs, etc.  
 Dust removal for acceptance and assembly of cameras, watches, lenses, etc.  
 Static electricity removal prior to painting of car bodies, and plating of resin products.  
 Preventing dust adherence during packaging, preventing infiltration of foreign matter into containers, countermeasures to trouble caused by static electricity in various industrial fields.



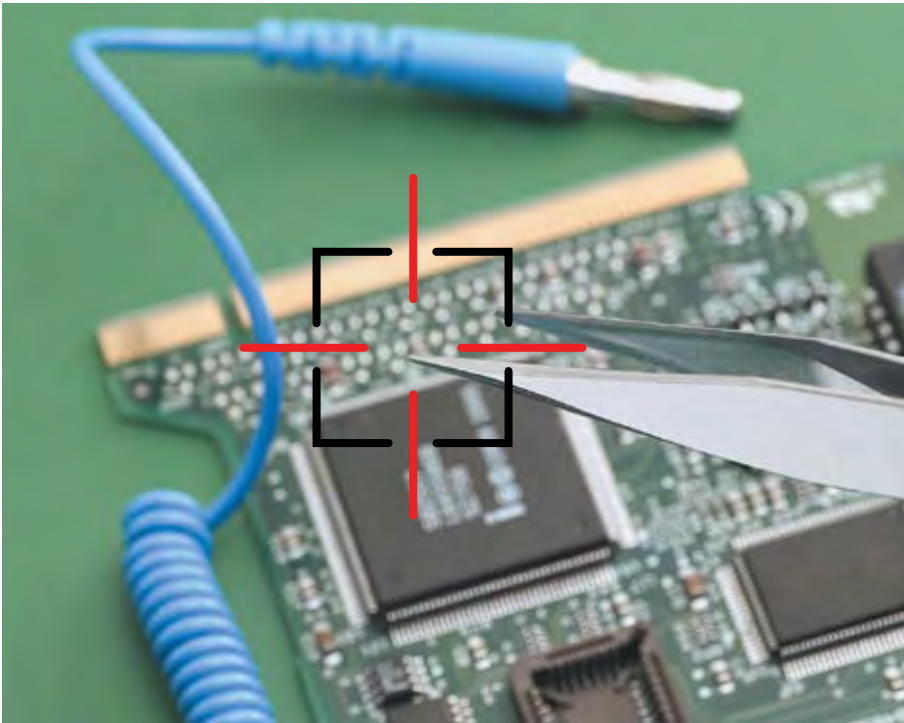

When static electricity generates on a parts tray or workbench for the manufacturing or assembly of electronics parts, electronic components may be destroyed by static electricity.

Direct an efficient Ionized airflow toward parts placed on a work table

In cell production sites, many parts are placed around the workbench, therefore a large unit would be a stumbling block to smooth operation. Using the attached clip, the SDJ-08S can be installed on the workbench or bracing pole to save space. The SDJ-08S uses a highly reliable voltage transformer to keep ion balance within  $10 \pm V$ .



### Features:

- Small and lightweight resin body weighs only 300g.
- The unit is easily installed by using the attached clip, and blow direction and angle can be easily adjusted.
- By detaching the clip, the SDJ-08S can be installed on an automatic adjuster or set on the top of a desk/workbench.
- The discharge wire is located near the point where the blown air moves at the fastest speed, enabling ions to be effectively transferred far and wide.
- The SDJ-08S is equipped with a warning alarm and external output terminal that transmits troubles like high-voltage or fan failure.
- Unique 100 hour times signals workers with a flashing lamp, indicating necessary discharge needle cleaning.

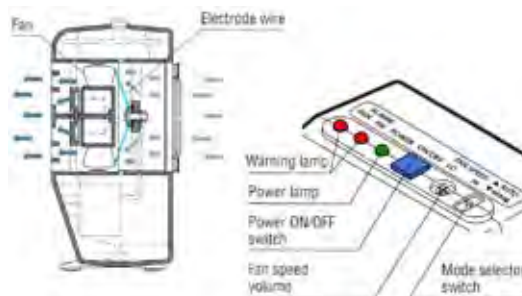

### Application:

Static removal for electronic device manufacturing and assembly, test and manufacture equipment, film and packaging separation, static removal in feeders, molding machines. Prevents dust adherence for cameras, watches, lenses, etc., container processing, product conveyance and filling. Ideal for static removal of food packaging, cosmetics, medicing packaging, etc.

The functions of the IC and LSI are lost when electrostatic discharge (ESD) is generated toward them because ESD causes short-circuiting and damage to the joint of the semiconductor device, as well as wiring breaks and disconnections, for sensitive devices that can be easily damaged, systematic measures against ESD are required.



Sensitive parts require a highly efficient static eliminator that can reduce static electricity to almost 0V. If proper maintenance is not done, however, the ion balance is disrupted, causing reverse charging and air pollution.

Because the SDJ-09 adopts a capacity coupling method using eight discharging needles, it can generate stable ionic air with an ion balance of  $\pm 5V$ . With the help of a 100 hour timer that displays and informs the need for cleaning the needle electrode, the SDJ-09 can establish control standards for needle maintenance.

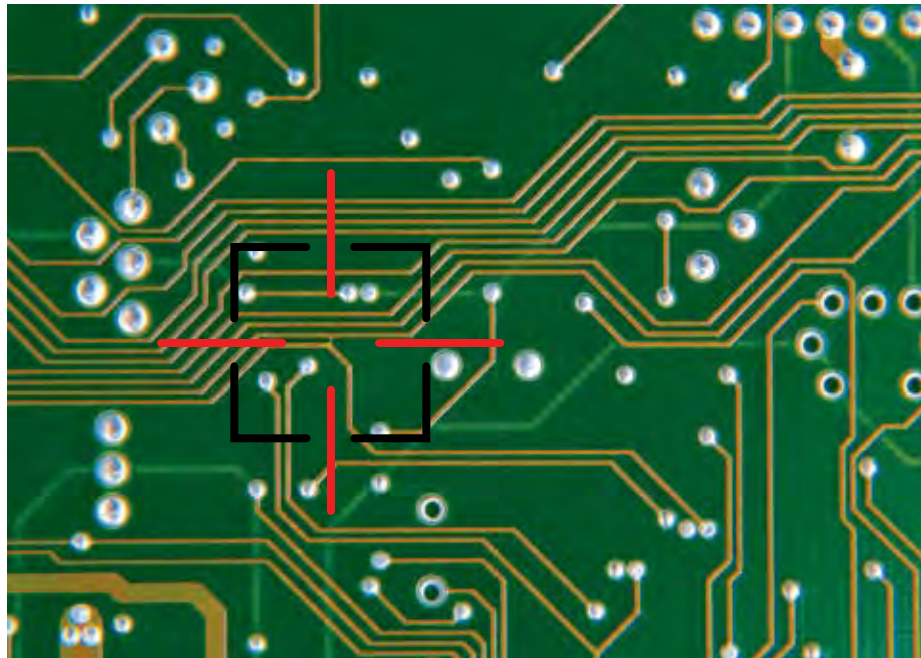

### 5V ion balance to prevent static electricity troubles in advance



#### Features:

- Highly reliable piezoelectric AC transformer
- Because the innovative disk-type discharge plate adopts a capacity coupling method, it can prevent the disruption of ion balance and is ideal for the removal of static electricity from sensitive electronic devices.
- Easy cleaning and replacement of the discharge plate.
- Equipped with a warning lamp that indicates troubles such as high pressure and fan failure.
- Unique 100 hour timer signals workers with a flashing lamp, indicating necessary discharge needle cleaning.

#### Application:

Static electricity removal for electronic devices manufacturing and assembly workstations, Static electricity removal for manufacturing and assembly of optical devices, watches, precision parts, etc. Static erasure from processing and filling of food containers, film lamination, and peeling of LCD panels. Prevention of adhesive stringing in gluing processes, Static erasure of molded parts on conveyors, dust adherence prevention prior to printing and coating. Static erasure for stockers, winders and Thompson punching and cutting processes for paper, film, and sheet. Static erasure of oscillating parts loaded into parts feeders.

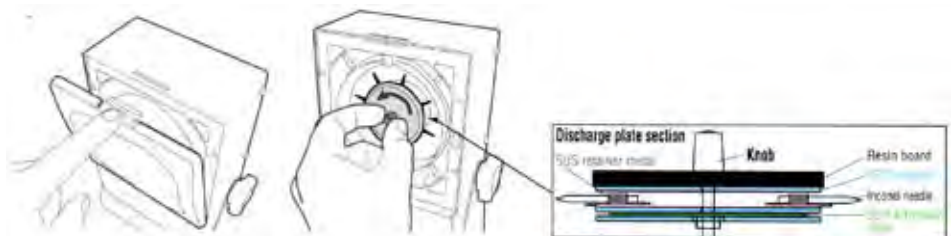

# Replacement Parts for Stat-Busters



## Discharge Needles



**SDJ-02RH**  
**SDJ-06H**

For use with:  
SDJ-02R, SDJ-03R, SDJ-06R



**SDJ-09H**

For use with:  
SDJ-09

## Filters



**SDJ-08F**

For use with:  
SDJ-08



**SDJ-09F**

For use with:  
SDJ-09

## Pin Spot Nozzle



**SDJ-03PN**

For use with:  
SDJ-02R, SDJ-03R, SDJ-06R

## Flare Nozzle



**SDJ-03FN**

For use with:  
SDJ-02R, SDJ-03R, SDJ-06R

## Cap Nozzle



**SDJ-02SN**

For use with:  
SDJ-02R, SDJ-03R, SDJ-06R

## Power Adapters



**AD24-06**  
**AD24-06EX**



**AD24-08**  
**AD24-08EX**



**AD24-09EX**

	AD24-06	AD24-06EX	AD24-08	AD24-08EX	AD24-09EX
Rated Input Voltage	100V AC (50/60Hz) 19VA	100-240V AC (50/60Hz) 1.3A	100-120V AC (50/60Hz) 40VA	100-240V AC (50/60Hz) 0.4A	100-240V AC (50/60Hz) 0.4A
Rated Output Voltage	24V DC 0.3A	24V DC 0.5A	24V DC 0.65A	24V DC 0.65A	24V DC 0.75A
Applicable for	SDJ-06R	SDJ-06R	SDJ-03R SDJ-08 SDJ-09	SDJ-03R SDJ-08 SDJ-09	SDJ-03R SDJ-08 SDJ-09



Frictional electrification is caused when a resin mold product is removed from the mold. The generation of this strong static electricity draws airborne dust to the product.



The locator is indispensable towards resolving "invisible static electricity trouble" The SDL-01 checks the charged state of products or packaging materials, the positions of static electricity removers, and confirms the removal of static electricity from the product.

Unseen static electricity is displayed for easy detection

**Features:**

- The potential of charged item is digitally indicated without making contact. Invisible static electricity can be easily measured.
- Voltage is measured and indicated in units of 100V in a range from -19.9 to +19.9KV every 0.5 seconds.
- Handy, portable, small and lightweight unit. Includes a storage case.
- Low power consumption. Can be used with 4AA batteries for about 6 months.

**Application:**

Checking resin molding, film, paper, packing containers, coated sheet metal surfaces, and testing the effect of static electricity removal.

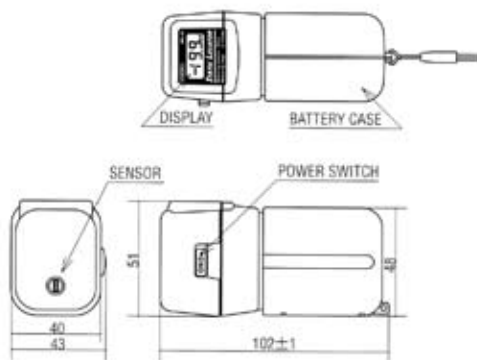
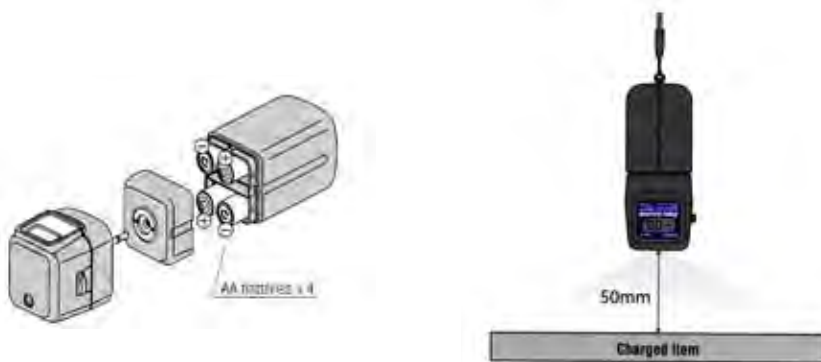

RANGE OF INDICATION: 0.0 to ± 19.9KV (0.1KV scale)
DETECTABLE DISTANCE: 50mm (between locator and charged item)
RESPONSE TIME: 0.5 seconds
AMBIENT TEMPERATURE: 0 ~ 40° C
AMBIENT HUMIDITY: 20 to 90% RH (no dewing)
DIRECTIVITY: Forward from the sensor hole
POWER SUPPLY VOLTAGE: 6V DC (4 AA batteries)
SIZE: H51 x W102 x D43mm
WEIGHT: 170g (including batteries)
ACCESSORIES: 4 AA batteries, 1 soft case



The *EXCLUSIVE* North American distributor of



**JDV Products, Inc.**  
22-01 Raphael Street  
Fair Lawn, NJ 07410 USA

**Tel: 201-796-1720**  
**Fax: 201-796-9399**  
**sales@jdvproducts.com**  
**www.jdvproducts.com**

*Distributed By:*

