

Demag Standard Cranes

Performance and efficiency at the highest level



Demag sets crane standards for the future

Standard solutions made by Demag offer outstanding quality, efficiency and reliability at the highest level. Every crane and every crane component reflects decades of crane expertise and reliability as a partner for the industry.

Innovation for greater efficiency to benefit our customers

With the new DR rope hoist, Demag Cranes & Components has introduced an extended state-of-the-art for standard crane applications with loads weighing up to 50 t and, at the same time, an entirely new crane philosophy.

The C shape of the Demag DR rope hoist design is ideally suited to crane applications. Thanks to the many benefits offered by the new DR rope hoist, the entire crane operates much more efficiently.

- Reproducible connection geometry and effective spare parts management offer an optimum planning and investment basis
- Proven crane geometry with welded crane girders guarantees high design rigidity, optimum travel characteristics and minimum wear
- Raised crane girders, designs tailored to match the roof structure and compact crabs with minimum approach dimensions facilitate larger hook paths as well as better utilization of the available space and reduce initial construction and subsequent costs
- Ergonomic operating elements and bi-directional radio control with load range display ensure highly convenient



38926-2

- operation and safe load handling. The display provides complete transparency for control of the installation.
- Infinitely variable speed control in all motion axes thanks to frequency inverter-fed drives reduces load sway, facilitates exact and gentle positioning and lowers the mechanical load on the crane installation
- High lifting and cross travel speeds provide faster handling rates and greater efficiency

Crane type	Suspension cranes	Single-girder overhead travelling crane	Double-girder overhead travelling crane
SWL* up to	5 t	10 t	50 t
Span* up to	14 m	30 m	
Long travel speed* up to	40 m/min		
Cross travel speeds* up to	30 m/min		25 m/min
Lifting speed* up to	12,5 m/min		
Stepless motions	3 axes		

* Other specifications on request



39343-2

Infinitely-variable speed control facilitates particularly gentle handling of the load

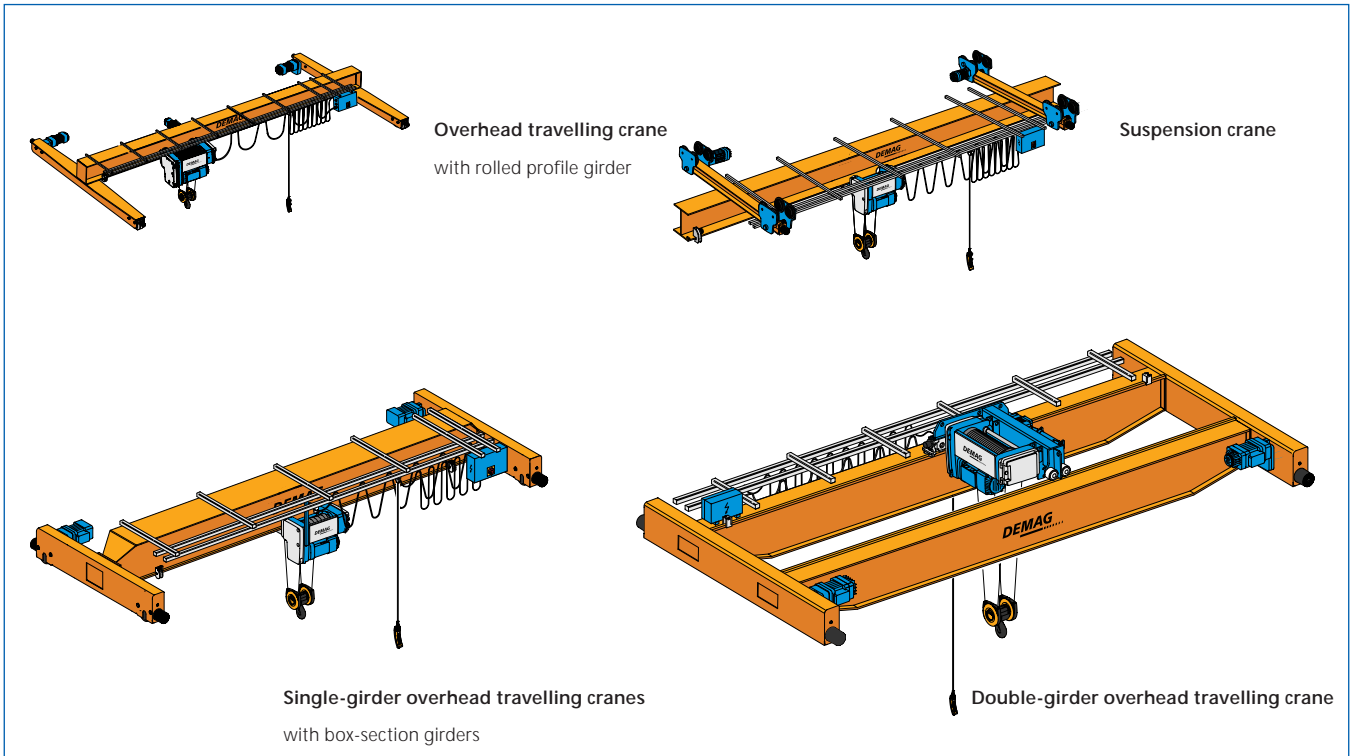

Attention to detail for total quality



End carriage

- Maximum stability thanks to a rigid box-section design with a reinforced connection featuring a welded diaphragm plate as well as engineering tolerances in the crane girder connection guarantee high inherent rigidity and optimum travel characteristics with minimum wear
- The precise travel wheel arrangement and exact adaptation to the crane span dimension thanks to interchangeable spacer elements ensure optimum travel characteristics and high adaptability
- Crane travel unit design with the aid of in-house static design programs and simple assembly thanks to good accessibility offer safety and efficiency

Travel unit

- Maintenance-free drives with anti-friction bearings lubricated for life, generous bearing arrangement to accommodate horizontal forces and travel wheels made of spheroidal graphite cast iron provide for favourable travel characteristics and minimum crane runway wear
- Infinitely variable travel speeds thanks to frequency inverter-fed drives with speeds up to 80 m/min without the need for any additional cabling and wiring guarantee low-vibration travel as well as precise positioning and reduce the load on the overall installation



Power supply line

- Demag DCL compact conductor line for 4 to 7 poles and screw-type connections ensures long-term power supply and minimises unplanned downtime
- Pre-assembled elements for simple assembly or replacement of current collector trolleys or complete straight sections provide optimum serviceability
- IP 23 or IP 24 high protection against accidental contact with sealing lip and integrated expansion compensation for optimum safety

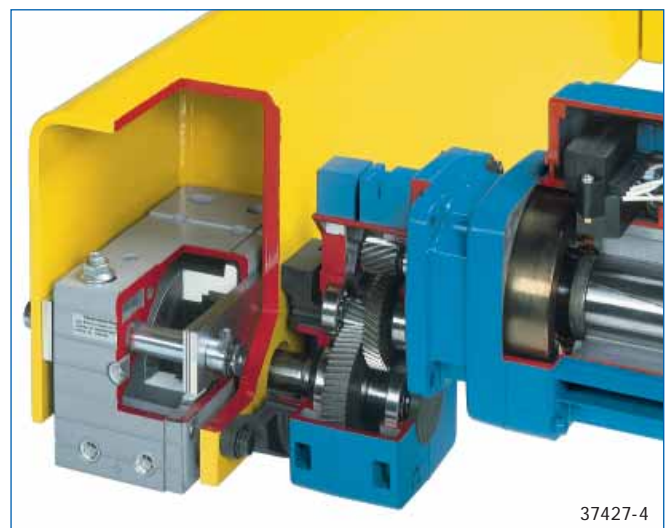

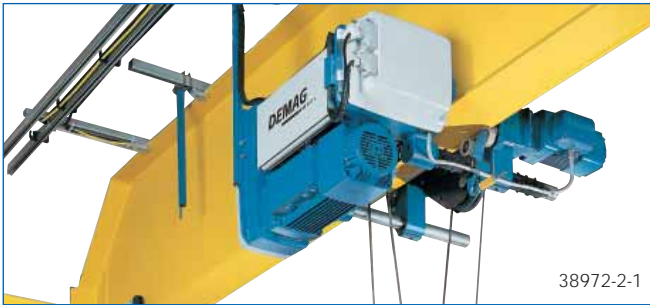

Crabs

- New Demag DR rope hoist of C-shaped design optimised for crane applications with higher hoist and cross-travel speeds provides higher handling rates and efficiency for cranes with capacities up to 50 t
- Compact designs with minimum approach dimensions and larger hook path guarantee optimum utilization of the available space and height and reduce initial construction and subsequent costs
- Infinitely variable hoist and travel motions guarantee low-sway handling. Precise, gentle positioning provides for greater safety and convenient operation
- CAN Bus technology to meet tomorrow's demands for high data transmission reliability, corresponding to safety class 3 to DIN/EN 954, ensure optimum monitoring for greater efficiency thanks to preventive maintenance

Control system

Ergonomically designed control units for safe, fatigue-free handling. The display provides complete transparency for control of the installation. The CAN Bus control system corresponds to safety category 3 to DIN/EN 954.

- Demag DLC line control
height-adjustable control pendant suspended for separate travel on the crane girder
- Demag DRC radio control
Demag radio remote controls with proportional pushbuttons for wireless control with variable radio frequency operation for unimpeded radio transmission
- Demag DRC-J joystick transmitter
Radio control with practical belt that can be comfortably worn from the shoulder

Bottom block

- New bottom block design with standard load hook for ease of load connection
- Rope lead-in guard eliminates the risk of being caught between the rope and sheave
- Handle recesses on both sides simplify handling of the bottom block and increase operating safety



Single-girder overhead travelling cranes with box-section girders

EKKE single-girder overhead travelling cranes provide you with Demag technology at a particularly attractive price. They feature maximum rigidity for a minimum deadweight. This keeps the load on the crane runway low, and a cost-effective design can be selected for the building. They also offer the benefits of outstanding crane geometry, resulting in exceptional travel characteristics. The new Demag EKDR rope hoist is the optimum design for crane applications, enabling the crane to meet your requirements for greater efficiency.

Benefits and features

- Computer-optimised box section as the crane girder
- End carriages of torsionally rigid, welded box girder construction
- Travel wheels of highly wear-resistant GGG 70 spheroidal cast iron with self-lubricating properties

- Connections between the main girder and end carriages manufactured to mechanical engineering tolerances for minimum wear
- Crab of low-headroom design with chain hoist or rope hoist, offering particularly favourable hook approach dimensions to serve the largest possible area
- Power supply to the crab via high-flexibility flat cable with protective earth conductor
- Control pendant suspended for separate travel on the crane girder, with display for installation monitoring
- Optional: radio remote control with display and proportional pushbuttons
- Optimum anti-corrosion protection of all parts thanks to pre-treatment of steel components to industry standard
- Paint finish in semi-matt golden yellow. Travel drives in azure blue. Crab powder-coated in azure blue and silver grey

EKKE single-girder overhead travelling crane

Technical data	
SWL	to 10 t
Span	to 30 m
Long travel speed	to 40 m/min
Cross travel speed	to 30 m/min
Hoist speed	to 12,5 m/min

Other specifications on request

Options

See accessories, page 11

Technical data sheet

Ident. no. 203 529 44

Optimum adaptation to the building design

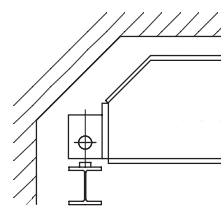

Type 1

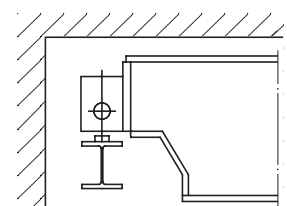

Type 2

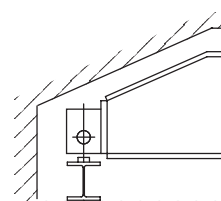

Type 3

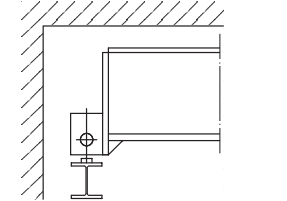

Type 4/5

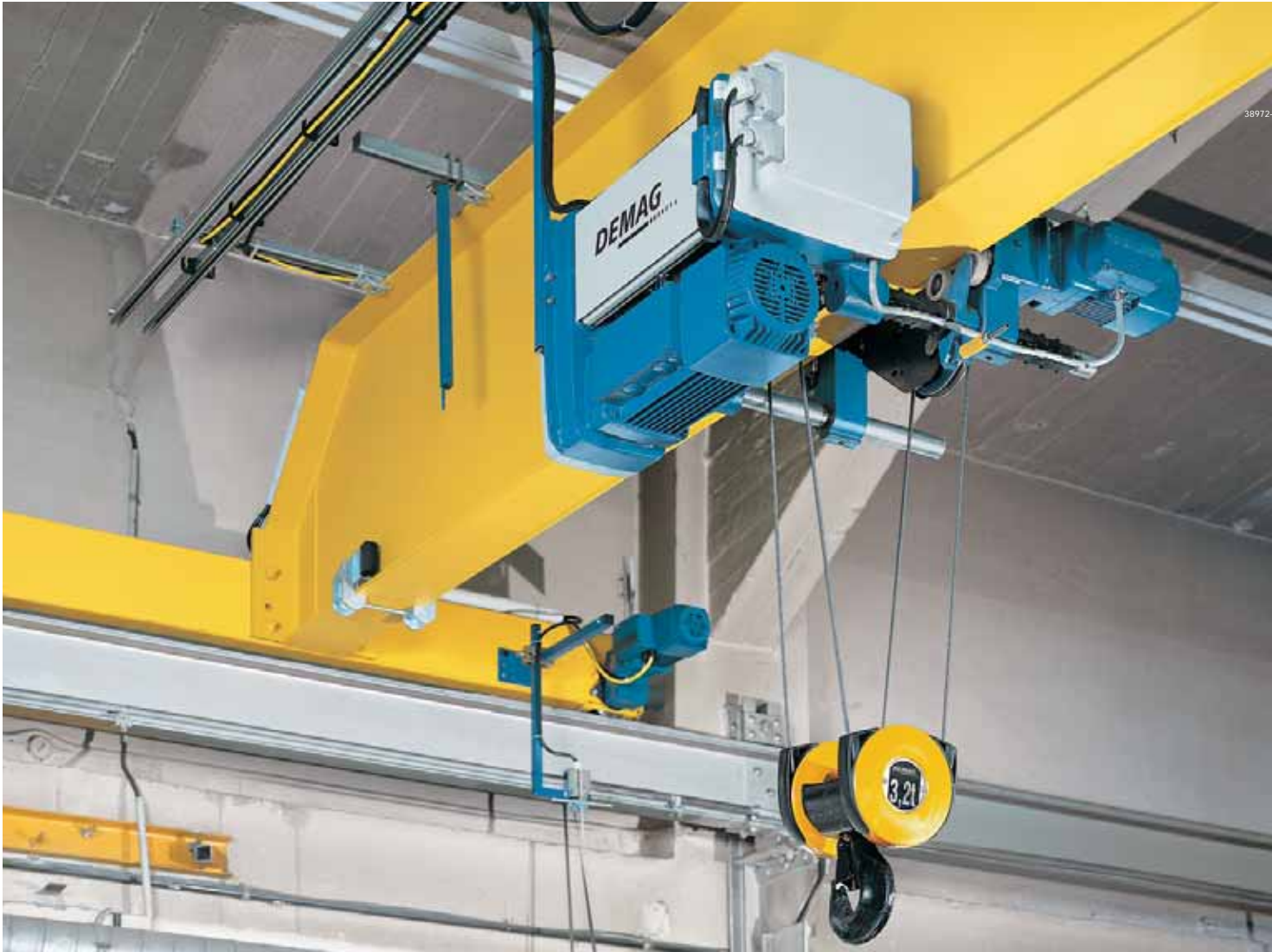

Your benefits with the new Demag DR rope hoist optimised for crane applications

- Increased efficiency thanks to extended 2m+ service life (1900-hour full load service life)
- Improved load handling due to increased lifting and cross-travel speed

- Low-sway load motions thanks to infinitely variable cross travel speeds
- Monitoring for improved installation transparency
- Improved utilisation of your production area thanks to minimum approach dimensions

Single-girder overhead travelling cranes with rolled profile girder

ELKE single-girder overhead travelling cranes with a rolled profile girder as the load bearing structure offer outstanding value for money. The use of rolled steel sections for the crane girder and travelling rope hoists of optimum design for crane applications make these cranes the optimum solution for light loads and relatively small spans. As a particularly inexpensive entry-level model offering the usual high level of Demag quality, ELKE cranes can be integrated into existing workshops or new buildings as workshop cranes, for example.

ELKE standard cranes ensure efficient and fatigue-free load handling thanks to the higher cross-travel speed and optimised ergonomic control pendants. When fitted with features such as infinitely variable-speed cross-travel drives, they also make it possible to achieve low-sway travel motions for gentle handling and precise positioning of loads.

In addition, they also offer high reliability and safety as well as a long service life combined with high levels of operating efficiency by all components.

Benefits and features

- Rolled section crane girder
- Optimum adaptation to the building design (page 6/7)

ELKE single-girder overhead travelling crane

Technical data	
SWL	to 5 t
Span	to 15 m
Long travel speed	to 40 m/min
Cross travel speed	to 30 m/min
Hoist speed	to 12,5 m/min

Other specifications on request

Options

See accessories, page 14

Technical data sheet

Ident. no. 203 541 44

Optimum adaptation to the building design

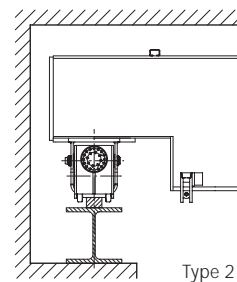
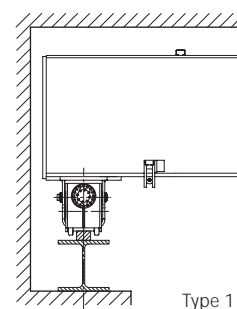

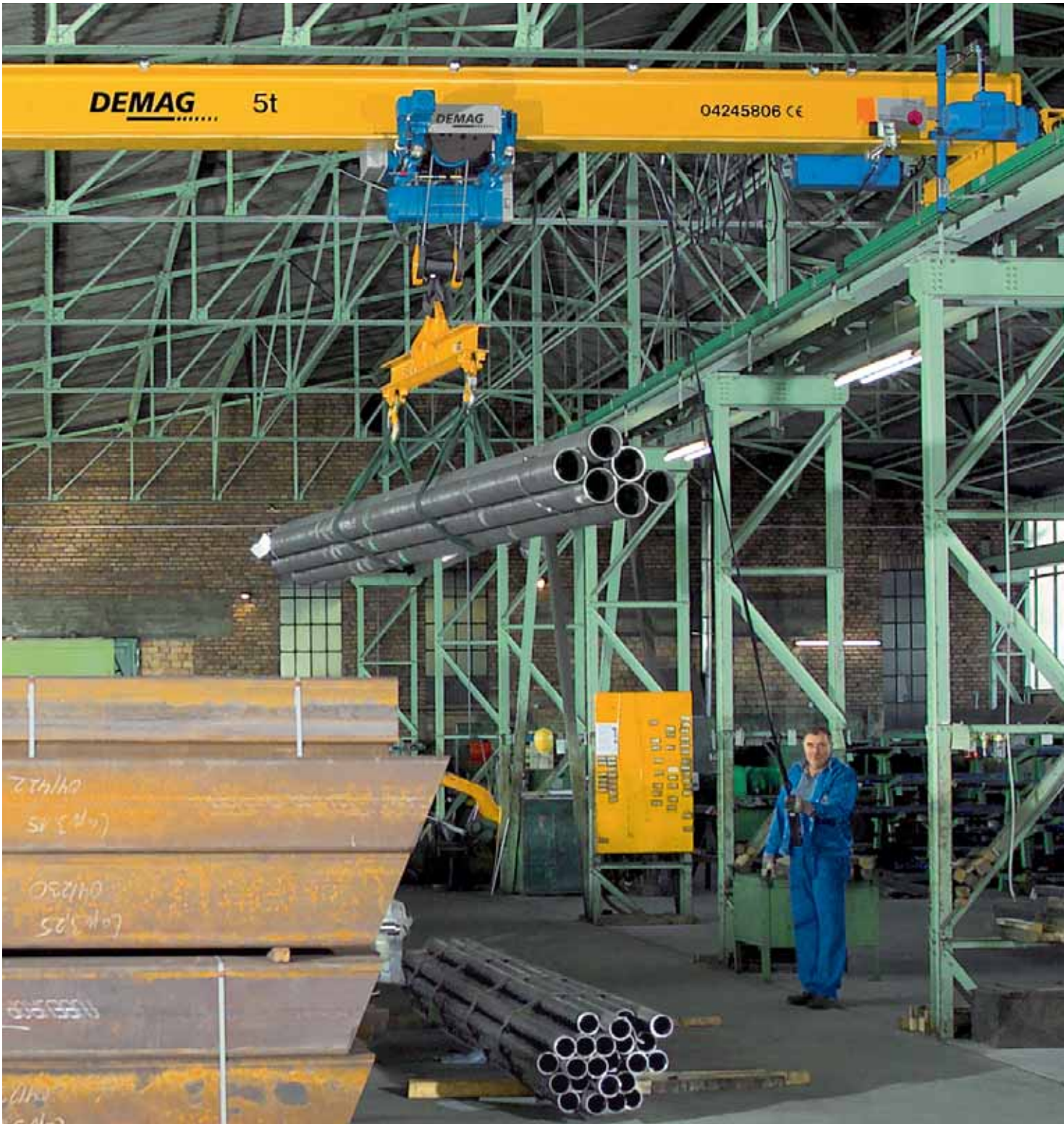

The standard display in the control pendant provides complete transparency for control of the installation

Suspension cranes – the column-free alternative

Simply attached to the existing roof structure, Demag suspension cranes save you having to install crane runway pillars. In this way, the entire workshop area is available for production. In addition, any sections of the workshop can be served. The lateral overhangs can be used and they extend the travel path of the travelling hoist beyond the span dimension. Optional latching devices make it possible to transfer the travelling hoist from the crane girder to a branch track and back without having to deposit the load.

Benefits and features

- Consistent quality with overhead travelling crane benefits (page 6/7)
- End carriages of optimised design to suit structure
- Rigid I-beam girders or welded box section girders for optimum load distribution
- Loads can be handled immediately adjacent to the building wall by means of girder ends tailored to the application requirements

EDKE suspension crane

Technical data	
SWL	to 5 t
Span	to 14 m
Long travel speed	to 40 m/min
Cross travel speed	to 30 m/min
Hoist speed	to 12,5 m/min

Other specifications on request

Options

See accessories, page 14

Technical data sheet

Ident. no. 203 549 44

Optimum adaptation to the building design

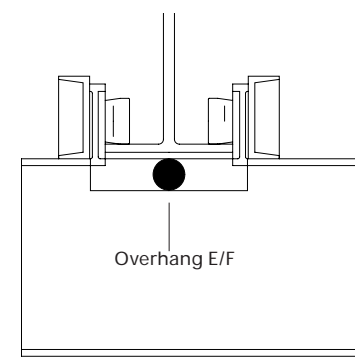



Radio control systems enable your cranes to be controlled from any position

Double-girder overhead travelling cranes – high load capacities combined with wide spans

Demag double-girder overhead travelling cranes offer you a virtually unmatched deadweight/load capacity ratio. They are also characterised by their outstanding crane geometry, ensuring extremely favourable travel characteristics and therefore minimising wear. The particularly large lifting height is derived from the fact that the load hook can be raised between the two crane girders. Depending on requirements, our double-girder overhead travelling cranes can also be fitted with radio or operator cab controls. Optional maintenance platforms and accessible crabs not only facilitate crane maintenance but also ensure that your hall fittings such as lamps, heating elements or supply lines can be quickly and easily reached.

Benefits and features

- Consistent quality with overhead travelling crane benefits (page 6/7)
- High performance thanks to double-girder design, facilitating high long and cross-travel speeds
- Low deadweight reduces investment layout
- Additional fittings
 - Optional maintenance platform for building repairs
 - Operator cab control as a crane control variant

ZKKE double-girder overhead travelling crane

Technical data	
SWL	to 50 t
Span	to 30 m
Long travel speed	to 40 m/min
Cross travel speed	to 25 m/min
Hoist speed	to 12,5 m/min

Other specifications on request

Options

See accessories, page 14

Technical data sheet

Ident. no. 203 561 44 (up to 16 t)

Ident. no. 203 660 44 (above 16 t)

Optimum adaptation to the building design

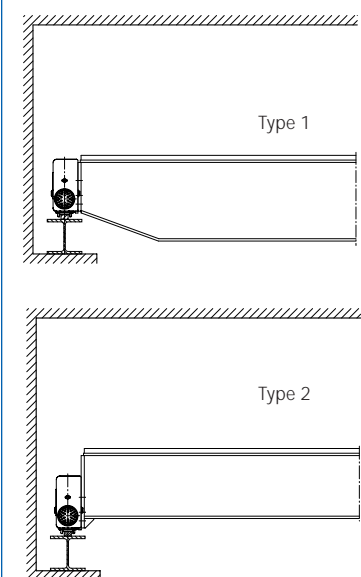



The double-girder design provides for particularly high load capacities and sensitive load handling thanks to infinitely-variable speed control

Demag crane accessories and auxiliary equipment

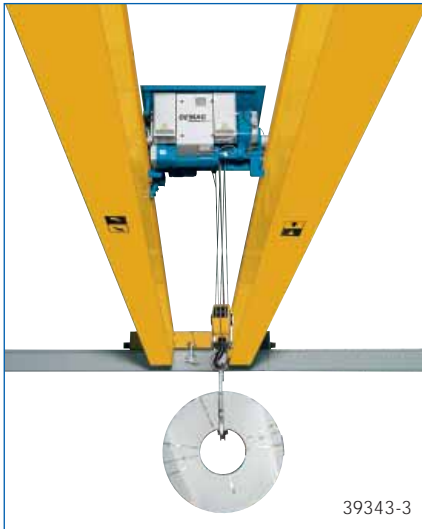

With our wide range of accessories and auxiliary equipment, we are able to adapt our standard cranes to the individual requirements of your application.

- Height adjustment of the control pendant makes it easier for you to attach the load
- Control by means of a pendant switch or, if required, bi-directional radio control with proportional pushbuttons
- Variable speed motors with frequency inverters help to avoid load sway

- Cranes fitted with two crabs make it easy to handle long and awkward loads
- A comprehensive range of load handling attachments satisfies the most varied requirements

Planners and plant designers are provided with a full range of technical documentation for each crane type, either as a conventional document or in electronic form on CD-ROM (order no. 227 049 44).

This means that you are able to incorporate your Demag Standard Crane solution within your overall plant design right from the start. This helps you to plan reliably and saves you time and money.



Double-girder overhead travelling crane with tandem end carriages for transporting and turning engine blocks

Demag Service – ready to help around the clock

We offer you service around the clock with our world-wide network of expert service teams. This ensures the highest availability and safety in your installation.

Rapid and reliable spare part supply

Any spare parts needed can be shipped 24 hours a day, 7 days a week.

Effective training of your employees

Your employees learn all they need to know about hoists and crane installations in training courses lasting one or more days. Operator and product training courses increase productivity, familiarisation with the relevant regulations contributes towards maximum safety at the workplace. Training courses can be held at our training centres and at your company.

Comprehensive monitoring reduces downtime

The performance and safety status of your installation are kept under surveillance by the monitoring system. A diagnostics tool constantly shows the operator or maintenance engineer the relevant status information and any unusual operating status, if applicable.

This enables any necessary maintenance and repair work to be identified and carried out in good time, downtime is reduced. Regular monitoring cuts maintenance and operating costs in the long term.

Your individual service package

Demag Service offers a comprehensive portfolio of services to ensure the lasting availability of your installation throughout its entire lifecycle:

- Recurring inspections according to relevant accident prevention regulations
- Inspection and maintenance according to contract schedules
- Fault elimination both with and without an on-call standby agreement
- Crane and crane runway surveys
- Service training for operators and maintenance engineers

On this basis, we can assemble a package tailored to meet your individual production and operating needs.





Crane system data can be read out for predictive and scheduled service

Demag Designer online – precise planning saves time, space and money

Demag Cranes & Components is not only a strong partner for perfect technical solutions to meet your in-house logistics requirements. We also provide you with support during the planning phase for overhead transport logistics.

One of the first steps towards efficient planning is selection of a crane tailored to meet your needs at the click of a mouse. Demag Crane Designer can be used to configure a crane installation that is tailored to your needs: in just a few minutes using the interactive application at www.demag-cranedesigner.com

You only have to enter a few parameters – the rest is done by the Crane Designer. From the comprehensive Demag product range, it selects a crane with the performance and technical equipment to suit your requirements precisely. Demag Crane Designer completes planning tasks in a minimum of time, for both single and double-girder cranes.

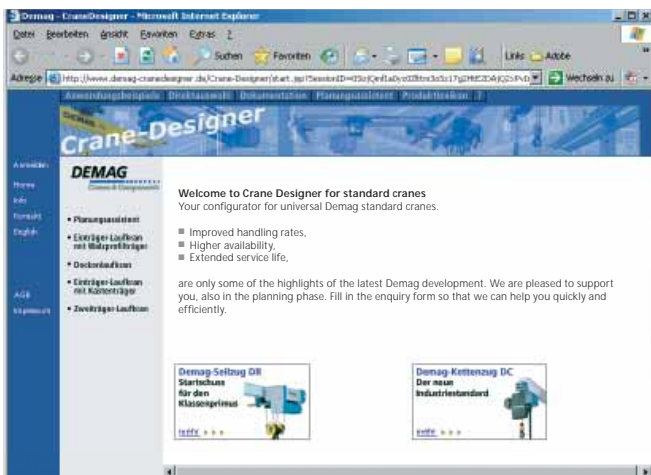

Online planning tool on the Internet. Configure your crane installations to meet your needs.

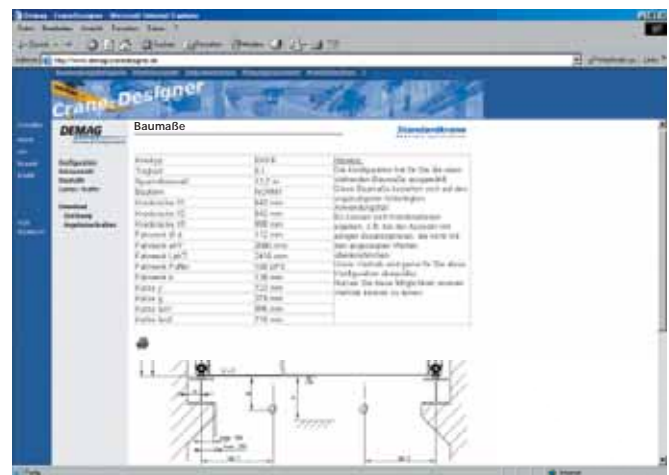

The Crane Designer calculates all relevant dimensions for your specific application.

Decisive advantages

- Requires no installation and no hard disk space
- Fast and individual selection
- Latest technical data and dimensions for your specified crane configuration
- Latest documentation in various foreign languages
- All information available round the clock worldwide
- Reliable transmission of your enquiry in the fastest possible way
- Possible connection to our online ordering system (www.demag-shop.com)

Visit the virtual planning consultant at
www.demag-cranedesigner.com

- Application examples with text and illustration
- “How to speak Demag” crane glossary explains technical terms
- Online crane configuration
- Online service:
 - Quotation texts
 - Technical information
 - Static design information
 - Individual CAD file

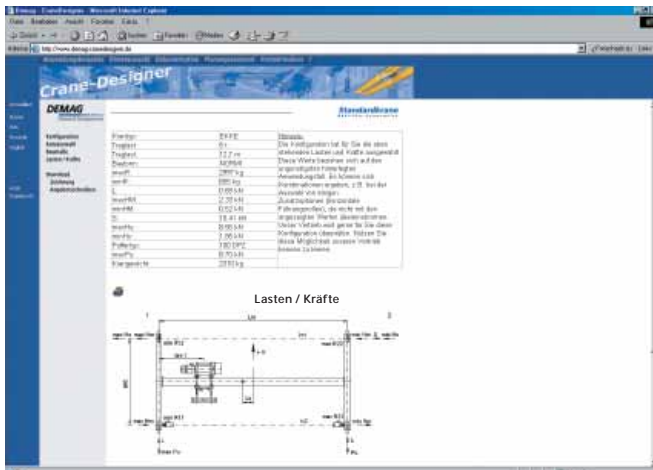

You are provided with information on loads and forces for further planning, e.g. to calculate your factory building dimensions.

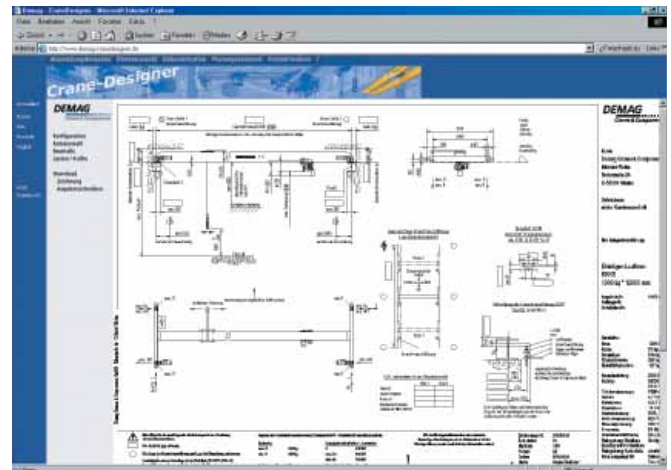

You can download the drawing file generated for your application and process all relevant data offline.

Demag Cranes & Components GmbH
Cranes
P.O. Box 67 · 58286 Wetter / Germany
Telephone +49 (0) 2335 92-7919
Telefax +49 (0) 2335 92-2339
E-mail standardcranes@demagcranes.com
www.demagcranes.com