

***Automotive Spring Pin.***  
*Positioning made easy.*







Small pin, big impact.

With the **automotive spring pin**, a new generation of spring pins has hit the market. Spring pins are used when several components have to be connected together. We guarantee optimum placement, especially in the case of soft materials such as plastic or aluminium. For this, we ensure that pre-tension is significantly reduced and that the outside edges are rounded.

The **automotive spring pin** is an easier and more cost-effective alternative to solid pins, coiled pins and fitted sleeves. It sets new performance standards and is the result of decades of practical experience in the field of technical connection systems.

We know the requirements that spring pins have to comply with.

 **automotive spring pin**<sup>®</sup>

***Automotive spring pin: it sets standards.***

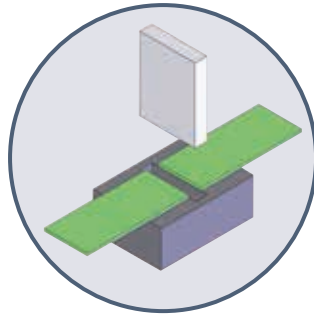

Metal blank

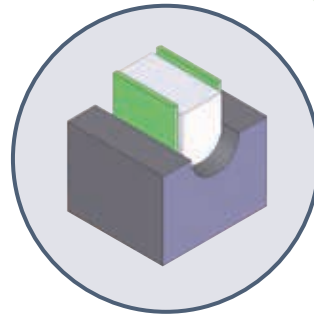

U-shape in a shaping process

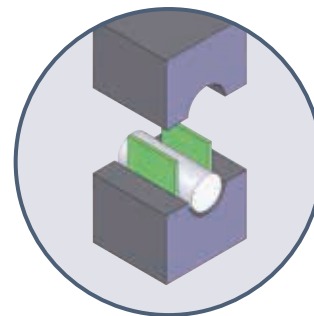

U-shape in a rolling process

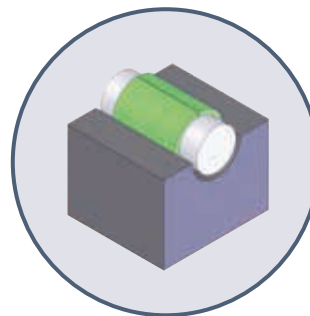

Rolled automotive spring pin

Many paths lead to the same destination. Success though, is a matter of taking the right one.

The path we take is the mandrel-rolling process. We have thoroughly thought through this process and have completely refined it so that you can realise your aims quickly. Many of the turned parts, deep drawn parts, coiled spring pins, solid pins and tube sections that are currently used can be simply replaced through designs that are more flexible and less expensive. Many companies are amazed at what there is still to discover in their production departments and that production still takes place using the mandrel-rolling method.



***The curling process: so that everything is kept on track.***

automotive spring pin

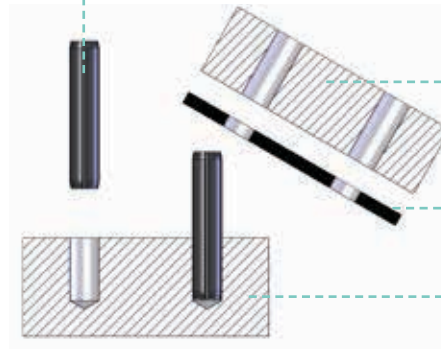

cylinder head

cylinder head seal

cylinder block

Individual parts

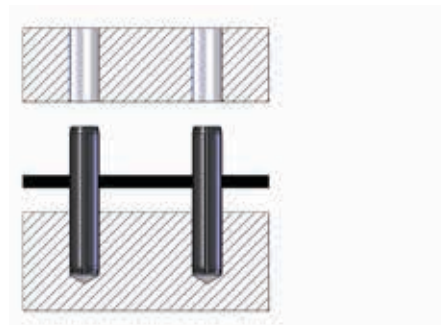

ASP driven in the base component



Positioned component

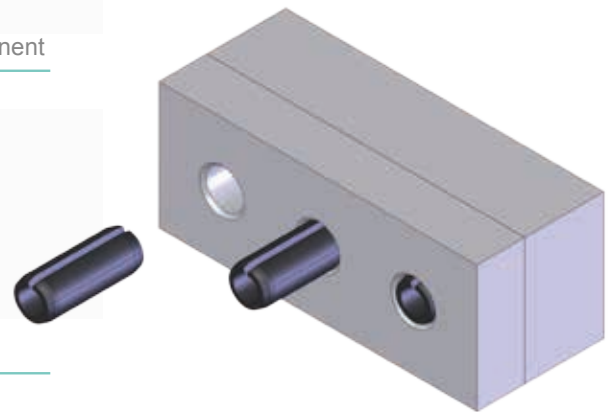

#### Application: positioning pin

In the automotive sector, various components are positioned and screwed into place. The automotive spring pin helps to position the parts accurately. For example, to achieve this, it is driven into a blind hole and the other components are positioned above. The pin aligns itself with the bore holes of the components and holds them in place, thus allowing the screws to fit the position and be carried out accurately.

***A wide range of applications.***

#### Optimized chamfers

The slot edges are at the intersection between the chamfer and the slot below the surrounding diameter. The pin is driven into the bore hole without any scraping action. As such, any risk of damage is eliminated

#### Slot width

- As a result of a defined design, the slot width avoids part nesting
- This way, the automatic feeding is most effective without high costs
- As a result of the tapered slot edge, damage to the insides of the bore hole is avoided

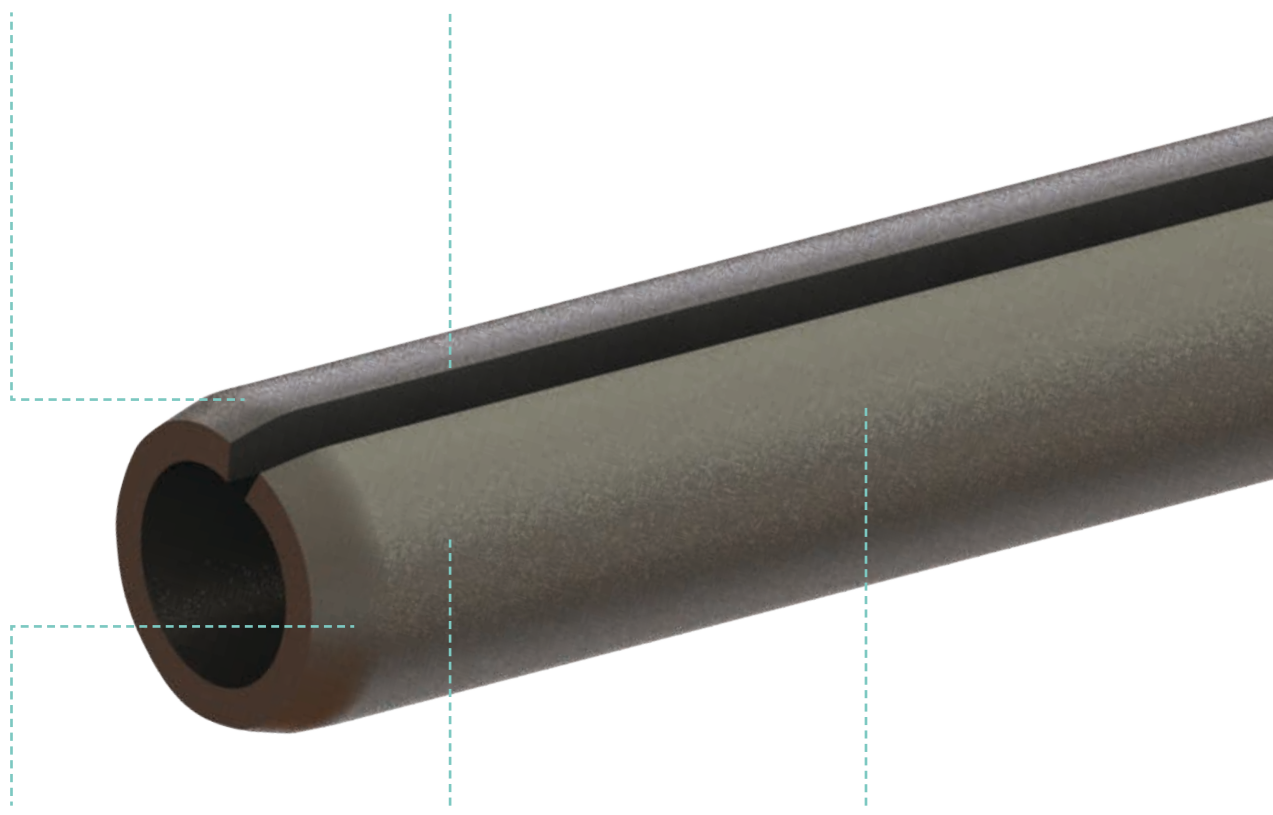
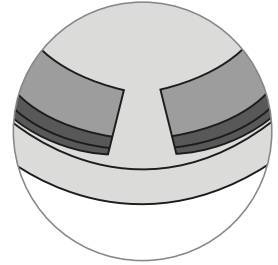

#### Rounded intersections

The slightly rounded intersections from the bearing surface to the chamfer allow for a burr-free installation

#### Heat treatment

Bainitic hardening results in an improvement of the dynamic properties

#### Material

In connection with heat treatment, the use of C67S (non-alloyed stainless steel in accordance with DIN EN 10132-4:2003) achieves the optimum combination of elasticity and hardness

***How the automotive spring pin works.***



### Open slot

The open slot allows for simple installation in a standard bore hole

### Cost savings

Lower manufacturing costs as a result of a more cost effective manufacturing process

### Weight savings

Efficient use of materials especially when compared to solid pins or even coiled pins

### Saves expensive process steps

The pin allows for larger bore tolerances than is the case with abrasive sleeves and solid pins. No need for cost-intensive processing steps

### Quality improvement

100% inspection, including hardness, monitoring of functional dimensions and third-party debris

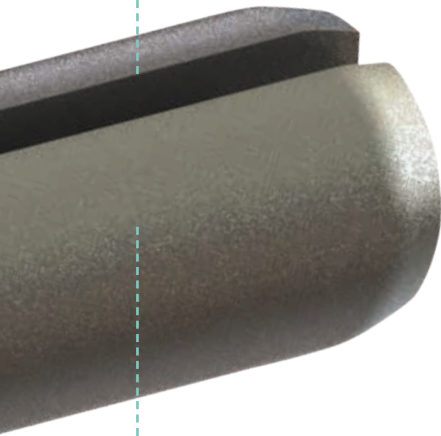

### Defined pre-tension

The spring characteristic provides the item with a secure hold in the bore hole

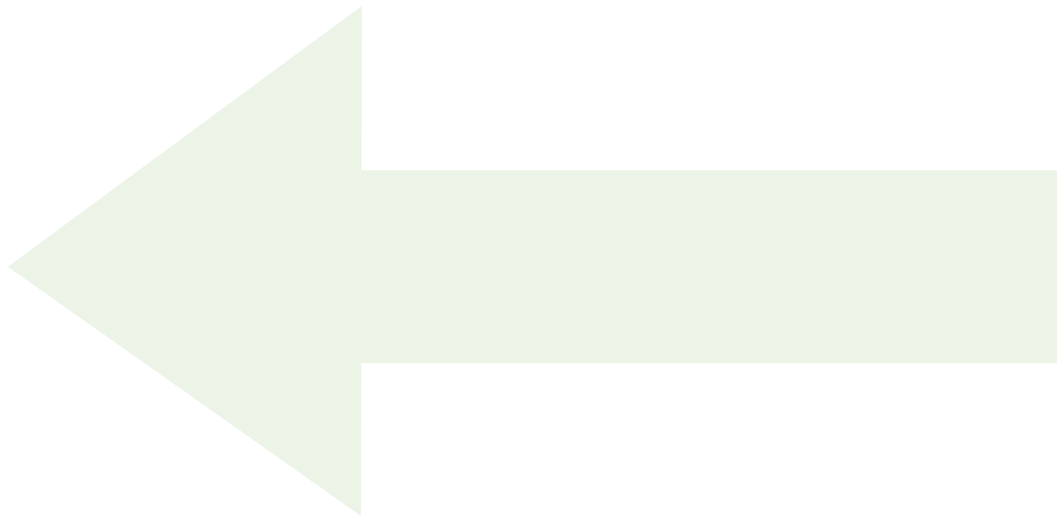



## Dimensions

Nominal size [mm]	Ød1		s	a		Minimum shear force, double shear kN	l												
	max.	min.		max.	min.		Tolerance	10	20	30	40	50	55	60	70	75	80	90	100
1.50	1.66	1.58	0.30	0.45	0.25	1.58	+0.25 -0.25	x	x	x									
2.00	2.19	2.10	0.40	0.55	0.35	2.82		x	x	x									
2.50	2.72	2.62	0.50	0.60	0.40	4.38		x	x	x									
3.00	3.25	3.14	0.60	0.70	0.50	6.32		x	x	x	x	x							
3.50	3.75	3.64	0.75	0.80	0.60	9.06		x	x	x	x	x							
4.00	4.30	4.16	0.80	0.85	0.65	11.24		x	x	x	x	x							
4.50	4.80	4.66	1.00	1.00	0.80	15.36		x	x	x	x	x							
5.00	5.33	5.17	1.00	1.10	0.90	17.54		x	x	x	x	x							
6.00	6.36	6.18	1.20	1.40	1.20	26.04	+0.5 -0.5	x	x	x	x	x	x	x	x				
8.00	8.45	8.22	1.50	2.00	1.60	42.76		x	x	x	x	x	x	x	x	x	x	x	x
10.00	10.51	10.25	2.00	2.40	2.00	70.16		x	x	x	x	x	x	x	x	x	x	x	x
12.00	12.55	12.28	2.50	2.40	2.00	104.10		x	x	x	x	x	x	x	x	x	x	x	x

Dimensions and tolerances apply to uncoated pins. Boxes marked with an „x“ indicate the standard dimensions. Other dimensions and variants are developed in coordination with you, depending on your specific application.

**The technical data.**



Automotive spring pin: used anywhere that precise positioning of components is a prerequisite for ensuring location.

The new generation of spring pins guarantee that it is possible to implement automated assembly processes smoothly and without trouble. This not only saves time, but also money.

The best and most secure solution is also the most economical. With the **automotive spring pin**, you play it safe.

Applications are often found in powertrains, e.g. in conjunction with the positioning and fixing of

- an engine block and cylinder head / cylinder head gasket
- intermediate plates or seals in the gears

***Advantages for all solid and soft materials.***

## Number of employees

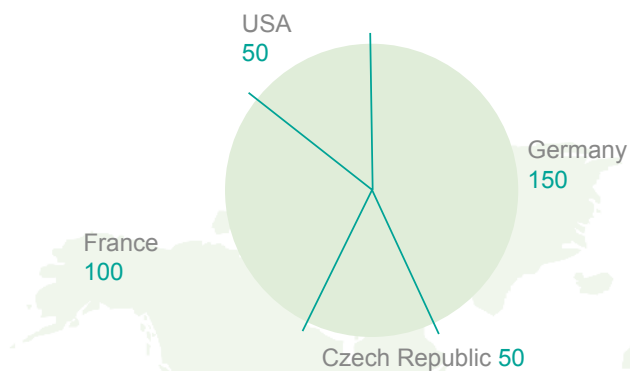

## Foreign sales

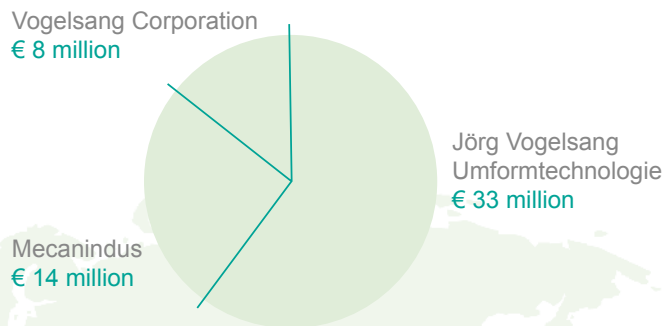

 Jörg Vogelsang Umformtechnologie  
> Sales/Production

 Mecanindus  
> Sales/Production

 European Parts Company  
> Production

 Vogelsang Fastener Solutions  
> Sales

 Japan  
> Sales

 China  
> Sales  
> Production (from 2014)

### Everything on board and on time

We are well-known for the inexpensive and quick handling of all orders. Thanks to our sophisticated logistics concept, timely delivery is always guaranteed. We are there whenever and wherever you need us. Furthermore, we offer various additional services such as packaging according to customer requirements, reliable stock management and much more besides.

### Key data

Number of customers:	2,000
Number of products/variants:	5,000
Area of company premises:	55,000 m <sup>2</sup>
Delivery items:	> 1 billion units p.a.
Material use:	15,000 t
Industry certifications:	ISO TS 16949 ISO TS 14001
Automotive sales:	80 %

### Manufactured range

- Spring pins
- Coiled spring pins
- Tension bushings
- Chassis components
- Compression limiters®
- Automotive spring pins®
- Guiding and positioning sleeves

***You can rely on a wide range worldwide.***

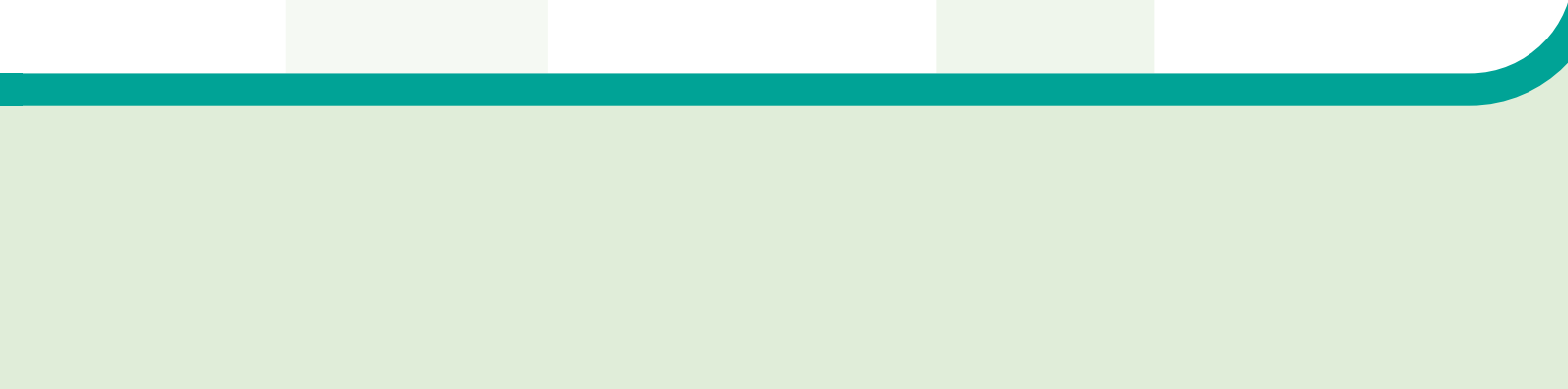
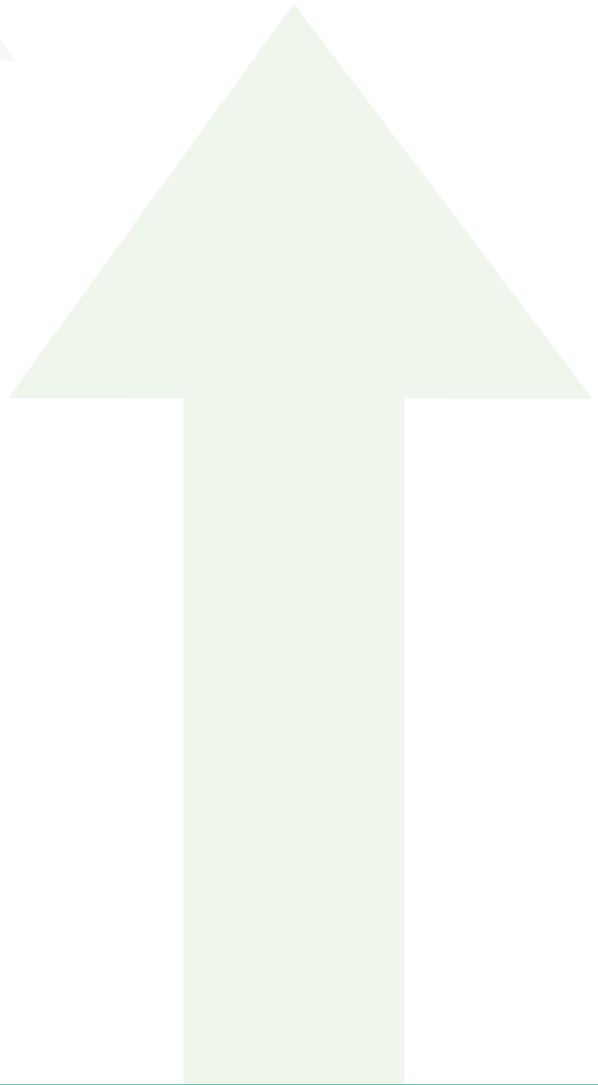
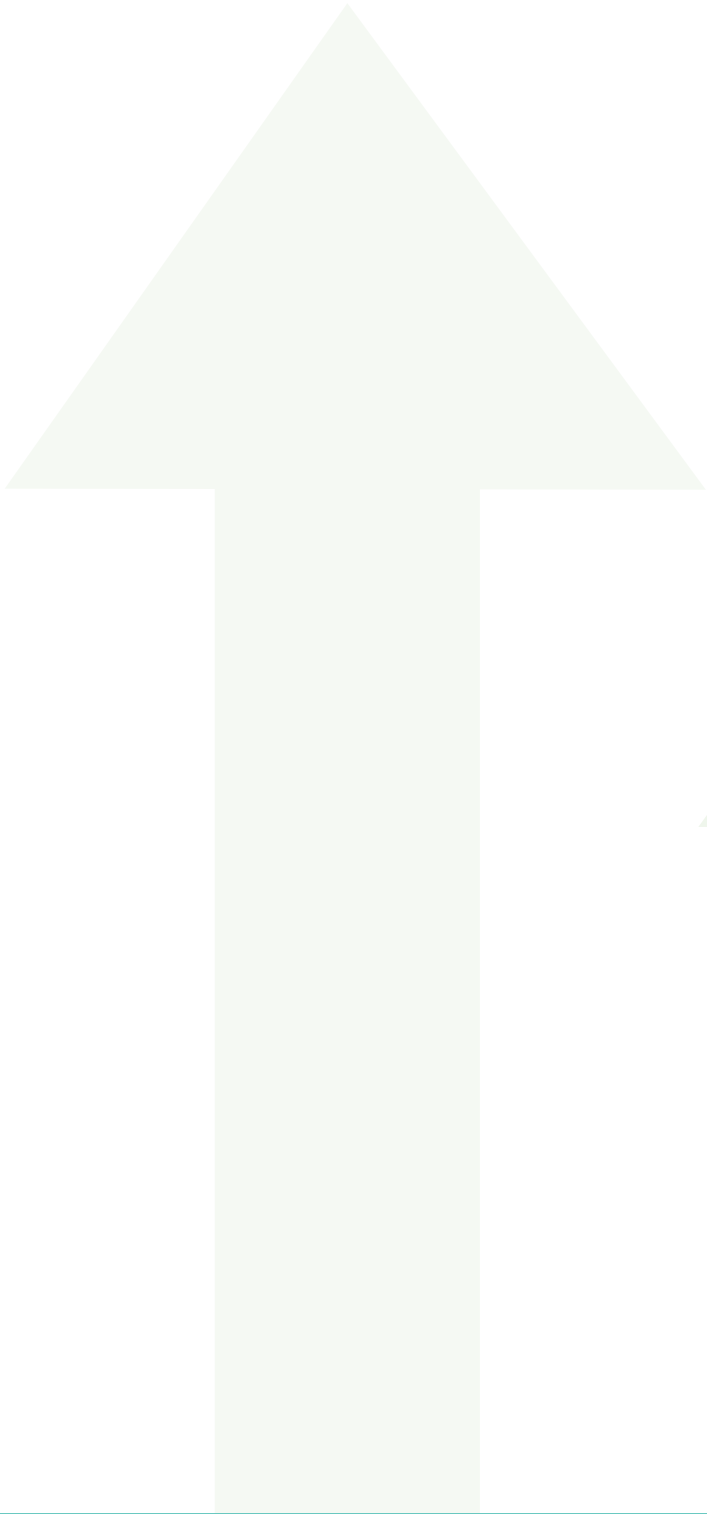



The information provided in this publication is given in good faith. It does not provide any guarantee of the actual properties. Liability for damages is excluded.



**Jörg Vogelsang GmbH & Co. KG**

Spannstiftstraße 2  
58119 Hagen

Phone: +49 2334 957-0  
Fax: +49 2334 957-269

info@jvu.de  
www.jvu.de

**Vogelsang Fastener Solutions**

1790 Swarthmore Avenue  
Lakewood, NJ 08701, USA

Phone: (800) 526-2376  
Fax: (732) 364-8111

vogelsang@vogelsangcorp.com  
www.vogelsangcorp.com