



ASSMANN POLYETHYLENE TANKS



Certified to NSF/ANSI 61

*The Assmann Difference
is in the Process*

January 2012





The Way We Process Makes the Difference

Assmann Corporation is a manufacturer of rotationally molded tanks, ranging from 40 to 12,000 gallons, engineered and processed for the most challenging chemical handling and storage applications.

Our commitment is to provide a superior tank for the harshest chemical service. Experienced tank users receiving an Assmann unit for the first time will remark favorably on how it compares with tanks already in their systems.

We begin by selecting resins with the best properties for the application based on our thirty plus years of molding and in-the-field experience. These include ExxonMobil LL-8461 (LLDPE) and Schulink XL-350 crosslink resin among others.

However, it is the processing (equipment, tooling and procedures) that will determine the quality of the final product.

Assmann polyethylene vertical storage tanks at a northern Illinois chemical company.



Assmann conical bottom storage tanks at a central Indiana chemical company.

The Way We Process

1. Molding

Our unique and efficient large ovens, which rotate end-over-end, receive convection heat from an adjacent stationary furnace. The oven shape and foil design create optimum airflow and uniform heat to set the first stage for the highest quality parts possible.

We rarely exceed 500° F in the molding process. Using higher temperatures will speed up the cycle time and cut costs but will compromise the results, particularly in XLPE and thicker wall parts.

2. Cooling without water

We have separate chambers using only very high volume air movement to assure a gradual cooling of the mold and the part inside. This allows the cross-linking process, still taking place upon exiting the oven chamber, to complete all the way through the tank wall. This is essential to optimize the properties of the cross-linked part. (The whole idea is to achieve as close to 100% cross-linking as possible).

Even in 1.45" thick walls, we consistently attain gel test results (indication of % of cross-linking that has taken place) in the high 70's and low 80's. (ASTM minimum gel requirement is 60%).

It is also important to mention that tanks molded of linear resins, and processed in this manner, will also reach their optimum cure rate.

We introduce no water into our cooling cycle. Water spray or mist will speed up the process, but will abruptly stop the cross-linking and set up the stresses that will shorten the service life of the tank.

3. Tooling

Equally important in our process is that we do not "shield" the outside of our tank molds. We exceed ASTM design hoop stress minimums for the lower sidewall and carry this wall thickness as uniformly as possible throughout the entire tank for maximum structural integrity.

In a competitive marketplace it has become a common practice to wrap and weld layers of sheet metal (shielding) around the outside of the mold to reduce heat transfer and thereby reduce thickness over as much as 80% of the area of the tank. Upper sidewalls, domes and tank bottoms are often reduced to less than 25% of the thickness of the lower sidewall.

Some of the obvious consequences of this practice:

- There is greater damage when tank restraint systems are put to the test.
- Tank domes may collapse, even under snow weight.
- Stress cracking agents along with UV deterioration will accelerate dome failure.

Also, it is important to note "shielding" triggers a loss of control in the process resulting in uneven cooking and significant variations in gel percentages over the tank structure. This will also shorten the service life of the part.

Those using this technique sell it as "state-of-the-art" by marketing with such terms as "tapered", "engineered", "stratified walls", and "strategic material placement". The intent is only to reduce raw material costs. The savings, however, are rarely passed on to the end user.

Our Position

Since the rotational molding process uses no pressure it will yield a stress free tank or part, but only if basic processing rules are followed.

We at Assmann Corporation are constantly finding ways to increase efficiency in our process but will not abandon successful methods for any cost-cutting measure that would compromise the quality of the product for which we have become known.

Our plant personnel are our "experts". They have pride in the plant and their workmanship. All of us extend a welcome to visit our plant in Garrett, Indiana.

For information, quotations or plant tours, please call us at 1-888-357-3181.

Contents

Introduction	2-3
Contents	3
ISO/NSF Certification	4-5
Vertical Tanks and FDO	6-7
Double Wall Tanks and Accessories	8-9
Conical Bottom Storage Tanks	10
Cylindrical Horizontal Tanks	11
Free-Standing Horizontal Leg Tanks	11
Chemical Feed Stations	12
Miscellaneous Storage Tanks	13
Open Top Storage Tanks	13
Double Wall Base Containers	13
Rectangular Secondary Containment Basins	14
Cylindrical Secondary Containment Basins	15
Accessory Material Options Selection	16
Flange Fittings	17
Bulkhead Fittings	17
316 Stainless Steel Fittings	18
PVC Self-Aligning Dome Fittings	18
Polyethylene Welded Connections for Linear Tanks	19
Vent Assemblies	19
Fill Line Assemblies	20
Anti-Foam Elbow	20
Sight Gauge Assemblies	21
Leak Detection	21
Passive Restraint Assemblies	22
PE Restraint and Lifting Lugs	23
Reverse Floats	23
Tank Heat Tracing and Insulation	24
Fiber Reinforced Ladder Assemblies	25
Agitator Support Brackets	25
Chemical Resistance Data	26-27
Checklist of Information	28
Assmann Corporation of America Warranty	28



ISO 9001:2008

“ISO” International Organization for Standardization is a family of standards for “quality management systems.” Assmann Corporation of America has been ISO Certified since 1994.

An ISO certificate is not a once-and-for-all award, but must be renewed at regular intervals recommended by the certification body, usually around three years. Two types of auditing are required to become registered to the standard. Auditing by an external certification body and audits by internal staff trained for this process. By regular auditing, we are required to constantly improve our systems.

ISO audits engineering and manufacturing processes for effectiveness and continuous improvement. This monitoring helps Assmann Corporation set achievable goals, track our goals and best of all complete them. Assmann Corporation employee’s commitment to the ISO program is second to none; our entire staff monitors each individual stage of our manufacturing process for errors and possibilities for improvement.

ISO forces Assmann Corporation to place the concept of process management front and center. “Process management” is the monitoring and optimizing of a company’s tasks and activities, instead of just inspecting the final product. By regulating and monitoring our process, we continue to improve our products. This constant review makes us proactive rather than reactive to process design flaws and virtually eliminates poor quality products from ever being supplied.

What does this mean to you? Assmann tanks are designed and manufactured under strict quality control standards. Each tank we manufacture has its own quality control and routing card that links the product back to date of manufacture, raw material lot numbers, and processing times. This complete traceability is critical especially when governing laws are being created daily regarding bulk chemical storage.



Certified to NSF/ANSI 61

Assmann Polyethylene Tanks are NSF Certified

- **Assmann Corporation’s Crosslink Tanks are approved for chemical storage by NSF!**
- **Schulink XL-350 Crosslink Resin**
- **Assmann is the FIRST Crosslink Tank approved by NSF for chemical storage!**

NSF is an independent testing company that requires Assmann Corporation of America to comply with strict standards. These standards require extensive product testing and material analysis. NSF undertakes a complete evaluation of our product development before we can meet their certification.

NSF / ANSI 61 program is responsible for the certification of drinking water treatment chemicals and drinking water system components to ensure that these products do not contribute contaminants to drinking water that could cause adverse health effects.

Assmann Corporation’s crosslink polyethylene tanks have been certified by NSF International to ANSI 61 standards for chemical storage. Assmann’s unique crosslink resin is certified for many chemical applications. Sodium Hypochlorite, Sulfuric Acid, and Sodium Hydroxide are within the list of chemicals our tanks can be used to store. For a complete list of certified chemicals, visit nsf.org.

In addition to our crosslink tanks for chemical storage, Assmann Corporation’s linear polyethylene tanks have been certified by NSF International to ANSI 61 standards for potable water. With both crosslink and linear polyethylene certifications Assmann Corporation can be your first source for both potable water & chemical storage for water treatment.

Our certification includes tank models ranging in size from 20 through 12,000 gallons.

Assmann Corporation of America



Garrett, Indiana Facility

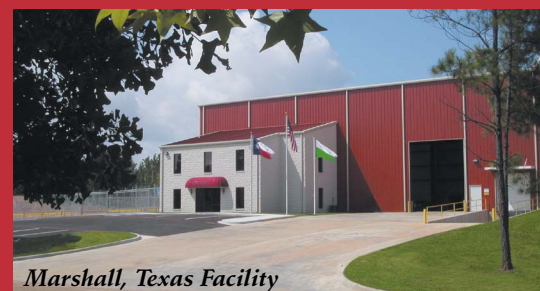

Marshall, Texas Facility

- *Vertical Tanks • Double Wall Tanks • Conical Bottom Storage Tanks*
- *Horizontal Tanks • Chemical Feed Stations • Miscellaneous Tanks*
- *Open Top Tanks • Fork Lifiable Containers*
- *Secondary Containment • Accessories/Fittings*

Assmann quality polyethylene tanks are manufactured in state-of-the-art rotational molding facilities in Garrett, Indiana and Marshall, Texas. Tanks up to 12 ft diameter by over 16 ft tall are shipped from these locations throughout North America.

Vertical Storage Tanks

Rotationally molded tanks from your choice of virgin high density crosslink or FDA-compliant linear polyethylene. Either is more corrosion and chemical resistant than fiberglass, stainless or mild steel. Tanks are semi-translucent, one-piece seamless molded units with gallon markers and access openings molded-in. Wall thickness conforms to ASTM D-1998 standards for liquid storage. Narrow diameters for space-saving in-plant use. They possess excellent low temperature impact resistance and are U.V. stabilized. Available in natural color or optional blue, green, red, yellow or black. Can be equipped with accessories to fit your needs.



Model Number	Capacity (US Gallons)	Dimensions (inches)		Weight (lbs) Linear and Crosslink Polyethylene				Access Opening (inches)
		Diameter	Height	1.35 Sp. Gravity	1.5 Sp. Gravity	1.9 Sp. Gravity	2.2 Sp. Gravity	
ICT 40	40	20	38	N/A	N/A	20	N/A	16
ICT 60	60	23	42	N/A	N/A	28	N/A	16
ICT 65	65	23	44	N/A	N/A	28	N/A	7
ICT 80	80	24	49	N/A	N/A	30	N/A	16
ICT 120	120	29	52	N/A	N/A	50	N/A	7
ICT 140	140	29	58	N/A	N/A	50	N/A	16
ICT 175	175	35	51	N/A	N/A	56	N/A	16
ICT 200 (35")	200	35	57	N/A	N/A	64	N/A	16
ICT 200 (36")	200	36	53	N/A	N/A	60	N/A	16
ICT 250	250	35	69	N/A	N/A	75	N/A	16
ICT 300	300	35	82	N/A	N/A	85	115	16
ICT 400	400	48	63	N/A	N/A	99	120	16
ACT 550	550	69	43	N/A	N/A	120	120	16
ICT 550	550	48	82	N/A	130	130	160	16
IFT 550	550	48	83	N/A	130	130	160	11
ICT 625	625	48	93	N/A	N/A	140	175	16
ICT 700	700	69	58	N/A	130	150	175	16
ICT 850	850	48	120	166	180	230	267	16
IFT 950	950	64	83	171	190	205	240	11
ICT 1000	1000	64	84	171	190	205	240	16
ICT 1100	1100	86	55	171	190	220	260	16
ICT 1200	1200	64	100	203	260	330	350	16
ACT 1500	1500	86	74	227	250	320	420	16
ICT 1500	1500	64	121	295	320	415	480	16
ICT 1850	1850	96	78	335	350	400	605	16
ICT 2000	2000	86	100	335	375	430	665	16
ICT 2050	2050	64	165	450	500	620	800	16
ICT 2400	2400	96	95	412	450	620	800	16
ICT 2500	2500	86	119	441	450	620	808	16
ICT 2900	2900	96	111	568	620	800	990	16
ICT 3000	3000	90	122	568	620	800	1035	16
ICT 4000	4000	90	162	782	850	1100	1620	16
ICT 4100	4100	119	108	782	850	1100	1400	24*
ICT 4200	4200	96	152	782	850	1100	1620	16
ICT 5200	5200	105	160	1101	1200	1550	1895	24*
ICT 5500	5500	119	141	1215	1350	1600	2200	24*
ICT 5600	5600	96	196	1350	1500	1750	2600	24*
ICT 6500	6500	105	193	1776	1900	2500	2850	24*
ICT 6510	6510	119	163	1575	1750	2000	2450	24*
ICT 7300	7300	119	177	2028	2244	2866	3299	24*
ICT 8000	8000	143	142	1989	2200	2800	3250	24*
ICT 8410	8400	119	201	2758	3065	3882	4495	24*
ICT 10000	10000	143	173	2700	3000	3400	4770	24*
ICT 12000	12000	143	196	3400	3800	4400	5340	24*

*All 24" manway access covers are hinged. Model number availability and individual specifications subject to change without notice. Gallonage and weights are approximate. All wall thicknesses conform to ASTM D-1998.

Molded In Full Drain Outlet - Patent Pending

Assmann Corporation of America offers an FDO (Full Drain Outlet) outlet assembly. This outlet provides the ability to fully drain your tank without the need for mechanically installed nozzles. The full drain assembly should be utilized where heavy solids or salts can accumulate in the bottom of the tank thus creating difficult maintenance work. This assembly virtually eliminates the need for confined space entry.

The assembly utilizes a metallic molded in insert. This insert is available in 316 Stainless steel, Titanium and Hastelloy C-276. These material variations allow us to store virtually any chemical in our tank.

Also unique about the FDO assembly is the fully replaceable polyethylene flange adapter. The adapter can be removed so that the tank can be installed on a flat surface without concrete pad. This also provides the ability to replace the flange in the event of chemical or mechanical damage without having to replace the entire vessel.

Assmann's Full Drain Outlet connection is available in two configurations providing the ability to configure the tank for ease installation and lower maintenance costs.

FDO Complete: This complete assembly comes with the "molded-in" full drain connection, polyethylene flange adapter, butterfly valve and flexible expansion joint. This assembly will be ready for installation.

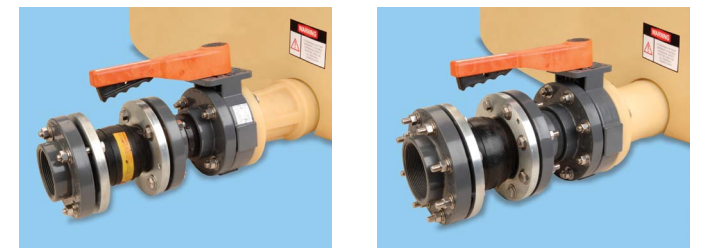

3" FDO (left) and 4" FDO (right) with flanged coupling, butterfly valve, and flexible expansion joint.

Modular Polyethylene Tank Stand - Patent Pending

Assmann Corporation now molds modular polyethylene tank stands. These stands are seismic and wind load rated plus easily disassemble, allowing the tank to be relocated to a different site. Stand elevates the polyethylene tank 12" from grade, providing the ability to fully drain the tank without the installation of expensive concrete pads. 100% chemical resistant and suitable for all corrosive environments.

Assmann tested this stand to over 300,000 lbs. of crush force.



Two people can easily lift the interlocking pieces and slide them together as shown.



Anchor points and raised castle projections restrain lateral movement.



Double Wall Tanks

Double wall tanks (IMT) provide the best protection against hazardous chemical spills into the environment. Inner tank dome overlaps outer tank sidewall to prevent rainwater, snow and debris from entering into the containment basin. Our ability to heat trace and insulate make these tanks perfect for temperature sensitive chemicals. Molded-in lifting lugs and upper fitting flats are standard. Molded-in lower fitting flats, along with a sturdy Assmann designed bottom outlet, reduce the cost of expensive double wall outlets.

All double wall tanks are designed with wall thicknesses equal to or greater than that required by ASTM D-1998 standards. Double wall tanks can be customized by adding Seismic zone 4 or 120 MPH wind load tie down assemblies, leak detection, ultrasonic level indicators, and ladders.

Accessories for Double Wall Tanks

- Seismic zone 4 restraint
- 120 MPH wind load restraint
- Ultrasonic level indicator
- Leak detection system
- High and low level alarms
- Heat tracing and insulation
- Fiber Reinforced Ladders
- Top discharge assemblies with foot valve
- Standard 16" or optional 21" top manways

Double wall tanks can be equipped with accessories to fit your specifications



Small Double Wall Tanks

This system consists of a primary inner tank and secondary containment, with a capacity of 120% of the inner tank, exceeding EPA standards and complies with 40 CFR-264.193.

- Inner tank dome overlaps outer tank sidewall to help prevent rainwater, snow, and debris from entering secondary containment, making system ideal for outdoor storage of chemicals.
- Molded 7" threaded top access opening is standard. This access opening is chemically resistant and fume tight. Larger access openings available.
- Small footprints of 34 1/2" & under will fit through standard 36" doorway to allow convenient system location within tight manufacturing areas.
- Molded in pump shelf is ideal for installing chemical pumps and metering equipment. This pump shelf is recessed in the top of the tank to contain small chemical spills.
- Recessed lower fitting flat will allow fittings to penetrate through the secondary containment wall and into the primary tanks sump. This feature allows full flooded suction for outlet assemblies.
- Interstitial leak detection systems option available.



Inner tank dome overlaps outer tank to prevent contamination.



Molded in pump shelf is recessed in the top of the tank. Shown w/optional metering pump.

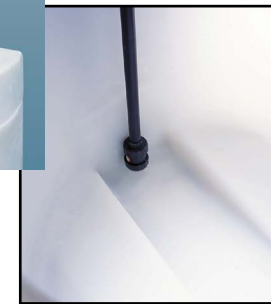

Molded in sump in the primary tank is located directly below the pump shelf. Suction lines can be lowered onto the sump area, which will allow for maximum drainage of chemical with top discharge assemblies.

Model Number	Cap. (US Gals)	Dimensions (inches)		Weight (lbs) Linear Polyethylene						Weight (lbs) Crosslink Polyethylene						Access Open. (in)
				Primary Sp. Gravity			Secondary Sp. Gravity			Primary Sp. Gravity			Secondary Sp. Gravity			
		Dia.	Hgt.	1.5	1.9	2.2	1.5	1.9	2.2	1.5	1.9	2.2	1.5	1.9	2.2	
IMT 550	550	60	73	N/A	130	159	N/A	130	151	N/A	130	159	N/A	130	159	16
IMT 1050	1050	72	87	185	205	233	191	244	283	185	205	226	176	221	256	16
IMT 1550	1550	72	123	325	408	472	309	392	454	297	380	440	283	359	416	16
IMT 2050	2050	72	159	551	691	809	596	748	875	505	633	738	545	697	799	16
IMT 2550	2550	96	119	643	823	953	499	632	732	600	748	866	457	579	671	16
IMT 3050	3050	96	138	817	1022	1183	694	879	1018	739	944	1093	636	806	933	16
IMT 4050	4050	96	177	1252	1607	1870	1178	1492	1728	1158	1476	1700	1178	1492	1728	16
IMT 5250	5250	119	154	1484	1920	2225	1342	1699	1968	1372	1753	2025	1230	1558	1804	16
IMT 6550	6550	119	186	2181	2778	3200	2028	2569	2974	2000	2570	2960	2028	2569	2974	16

Model number availability and individual specifications subject to change without notice. Gallonage and weights are approximate. All wall thicknesses conform to ASTM D-1998.

Model number availability and individual specifications subject to change without notice. Gallonage and weights are approximate. All wall thicknesses conform to ASTM D-1998.

Conical Bottom Storage Tanks

Conical bottom tanks (OTCB, ICB) are available in seamless molded one piece units from either virgin high density crosslink or FDA-compliant linear polyethylene. A funnel shaped conical bottom with 30° or 45° slope is molded-in as are gallon markers and access openings. They have more resistance to corrosion and chemicals than fiberglass, stainless or mild steel. Wall thickness conforms to ASTM D-1998 standards for liquid containment. They possess excellent low temperature impact resistance and are U.V. stabilized against degradation by sunlight. Factory approved steel support work is required or can be supplied. Tanks are available in natural color or optional blue, green, yellow or black. Other options include agitator support brackets, ladders and tie-down assemblies. They can be equipped with accessories to fit your specifications.



NEW!

The APCB 560 gallon all polyethylene conical bottom tank and stand is best suited as a mix vessel for chemicals and corrosive acids. This one piece, full drain tank features molded in fitting placement flats on the tank roof, molded in forklift access for easy tank placement and four anchor points molded into the stand for stability.



Model Number	Capacity (US Gallons)	Slope (degrees)	Dimensions (inches)		Weight (lbs) Linear and Crosslink Polyethylene			Stand Weight (lbs)	Access Opening (inches)
			Diameter	Height	1.5 Sp. Gravity	1.9 Sp. Gravity	2.2 Sp. Gravity		
OTCB 300	300	45	49	88	N/A	115	133	210	Open Top
OTCB 600	600	45	57	105	N/A	180	208	260	Open Top
OTCB 1100	1100	45	69	109	173	218	255	350	Open Top
APCB 560	560	30	54	90	N/A	180	N/A	215	16
ICB 1100	1100	45	69	116	173	218	255	350	16
ICB 1575	1575	45	86	121	325	450	521	440	16
ICB 2200	2200	30	96	119	500	600	695	440	24 Top hinged
ICB 2600	2600	45	86	159	540	700	811	440	16
ICB 3000	3000	30	90	154	620	825	955	450	16
ICB 4200	4200	30	96	177	850	1000	1158	550	16
ICB 6000	6000	30	143	162	1800	1900	2200	3200	24 Top hinged
ICB 8000	8000	30	143	190	2000	2600	3000	3200	24 Top hinged

*All 24" manway access covers are hinged. Model number availability and individual specifications subject to change without notice. Gallonage and weights are approximate.

Cylindrical Horizontal Tanks

Cylindrical horizontal tanks (IHT, AHT) are available in various sizes and configurations. Consult factory for specific drawings or configurations. Factory approved steel support stands are required for all cylindrical horizontal tanks. Horizontal stands are standard with epoxy primer and top coat.



Model Number	Capacity (US Gallons)	Dimension (inches)		Weight (lbs) Linear and Crosslink Polyethylene			Stand Weight (lbs)	Access Opening (inches)
		Diameter	Length	1.5 Sp. G	1.9 Sp. G	2.2 Sp. G		
IHT 25	25	23	23	11	13	16	22	6
IHT 55	55	23	36	20	22	29	35	6
IHT 150	150	32	55	50	55	73	51	6
AHT 150	150	38	42	55	60	81	64	8
IHT 200	200	32	68	65	70	95	69	6
AHT 200	200	38	53	70	95	110	72	8
IHT 300	300	38	73	75	105	122	91	8
IHT 500	500	48	74	120	130	176	116	8
IHT 1000	1000	49	140	325	400	477	230	16
IHT 1650	1650	59	157	500	600	733	290	16
IHT 2500	2500	64	191	650	770	953	1100	21

Model number availability and individual specifications subject to change without notice. Gallonage and weights are approximate.

Free-Standing Horizontal Leg Tanks

Free-standing horizontal storage tanks (IHFS) are similar to the horizontal tanks above, except they have molded-in legs requiring no steel cradle support. Materials and features are similar to vertical and conical tanks.



Model Number	Capacity (US Gallons)	Dimensions (inches)			Weight (lbs) Linear and Crosslinked Polyethylene		Access Opening (inches)
		Diameter	Length	Height	1.9 Sp. G	2.2 Sp. G	
IHFS 55	55	26	33	30	30	35	7/11
IHFS 80	80	25 ¼	43 ¼	30 ½	45	N/A	7/11
IHFS 110	110	29	46	34	60	69	7/11
IHFS 200	200	35	58	40	85	98	7/11
IHFS 300	300	41	68	45	110	127	7/11
IHFS 500	500	47	76	50	145	168	7/11

Model number availability and individual specifications subject to change without notice. Gallonage and weights are approximate.

Chemical Feed Stations

Complete ready to use Chemical Feed Stations (CFS) allow you to handle small amounts of liquids and other chemicals without the handling costs and inconvenient disposal of drums. Lightweight, easy to handle, and self contained construction adds to the complete ready to use design. Added features such as molded pump shelves, polyethylene primary tank stands, custom design fittings, and accessories help to individualize any customer's needs. Chemical Feed Stations are constructed from high density crosslink polyethylene or FDA compliant linear polyethylene.

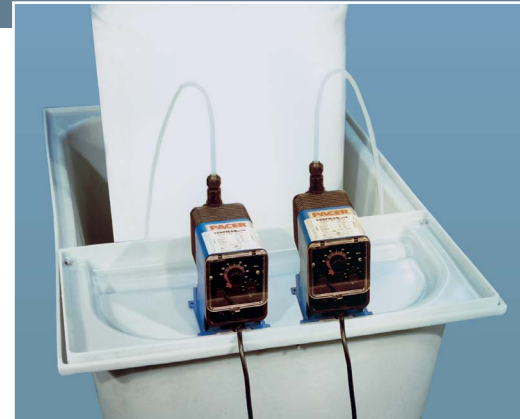

Polyethylene pump shelf supports most pumps and metering devices. Optional fiberglass shelves are available for pumps and metering devices totaling 25 pounds or more.

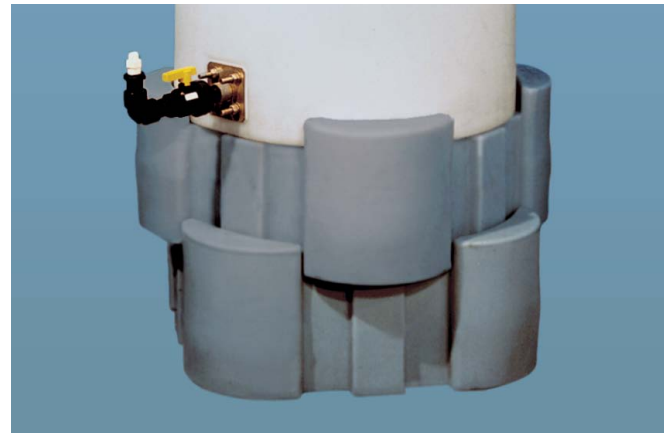

Optional polyethylene stands, which may be stacked 2-high, support the primary tank for gravity feed.

Model Number	Capacity (US Gallons)	Dimensions (inches)			Access Opening (inches)
		Length	Width	Height	
CFS 40	40	32	26	38	16
CFS 60	60	47	32	42	16
CFS 80	80	47	32	49	16
CFS 140	140	52	38	58	16
CFS 175	175	60	43	51	16
CFS 200	200	60	43	57	16
CFS 250	250	72	43	69	16
CFS 300	300	72	43	82	16
CFS 550	550	83	64	82	16

Model number availability and individual specifications subject to change without notice. Gallonage and weights are approximate. All wall thicknesses conform to ASTM D-1998.

Miscellaneous Storage Tanks

Industrial Mini Bulk (IMB) and Industrial Mini Drum tanks (IMD) are molded in either high density crosslink polyethylene or NSF Certified linear polyethylene. Molded polyethylene skids are optional for both IMB 120 and 200 models. These skids allow the tank to be lifted and re-located during non-use periods. The IMD series tanks have molded in baffles and forklift access.



Model Number	Capacity (US Gallons)	Dimensions (inches)		Weight (lbs) 1.9 Sp. Gravity		Access Opening (inches)
		Diameter	Height	Linear Polyethylene	Crosslinked Polyethylene	
IMB 120	120	40	30	40	40	6
IMB 200	200	40	44	50	50	6
IMB-Pallet	--	--	4	40	40	--
IMD 110	110	37	32	35	35	6
IMD 175	175	37	45	50	50	6

Open Top Tanks

Industrial Open Top tanks (IOT) are molded from your choice of virgin high density cross-link or NSF certified linear polyethylene. These flat bottom vertical tanks are molded with a stiffening lip on the top to give the tank rigidity, and they are equipped with shoe-box style cover. Assmann open top tank covers have a unique design that allows the lid to be hinged and stay open. Available in a variety of colors and in sizes ranging from 30 to 680 gallons. As an option for these tanks, Assmann offers both stainless steel and mild steel epoxy coated agitator support stands.



Model Number	Capacity (US Gallons)	Dimensions (inches)		Weight (lbs) 1.9 Sp. Gravity		Access Opening (inches)
		Diameter	Height	Linear Polyethylene	Crosslinked Polyethylene	
IOT 30	30	19	30	18	18	Open top
IOT 40	40	18	41	27	27	Open top
IOT 70	70	22	46	33	33	Open top
IOT 90	90	24	50	42	42	Open top
IOT 150	150	30	51	55	55	Open top
IOT 210	210	35	52	65	65	Open top
IOT 300	300	42	57	95	95	Open top
IOT 400	400	69	32	120	120	Open top
IOT 680	680	69	48	130	130	Open top

Double Wall Base Containers

Rectangular, low profile, chemical storage tank for various material handling applications. Features a primary tank that holds 450 US gallons, allowing intermediate bulk containers (IBC) to be quickly emptied and back on the road. Constructed from crosslink polyethylene or FDA approved and NSF Certified linear polyethylene.



Model Number	Capacity (US Gallons)	Dimensions (inches)			Weight (lbs) Linear and Crosslinked Polyethylene		Access Opening (inches)
		Width	Length	Height	1.9 Sp. G	2.2 Sp. G	
BC 450	450	73	73	44	802	N/A	11

Model number availability and individual specifications subject to change without notice. Gallonage and weights are approximate.

Rectangular Secondary Containment Basins

Secondary containment basins (IRD) are molded in virgin high density crosslink or FDA-compliant linear polyethylene. They have a tapered design for nesting during shipping. These meet or exceed EPA requirements for containment of dangerous chemicals. Check with local regulatory agencies for compliance in your area. When determining size of secondary containment basins, always refer to factory drawings to confirm primary storage tank size compatibility.



Model Number	Capacity (US Gallons)	Dimensions (inches)			Contains Tank Max. Diameter (inches)	Weight (lbs) Linear PE
		Length	Width	Height		
IRD 40	52	32	26	20	20	25
IRD 80	95	47	32	20	24	40
IRD 140	155	52	38	24	29	65
IRD 200	200	57 ½	45	24	35	75
IRD 240	240	60	43	28	35	80
IRD 275	275	64 ½	52	24	42	75
IRD 330	330	72	43	31	35	90
IRD 375	375	66	66	24	58	100
IRD 440	440	72	60	30	54	175
IRD 495	495	69	69	29	61	125
IRD 660	660	83	64	40	48	220
IRD 950	950	83	83	46	68	320
IRD 1650	1650	99	99	53	84	400
IRD 1750	1750	218	108	21	2 each 90	400
IRD 3500	3500	218	108	40	2 each 90	700

Model number availability and individual specifications subject to change without notice. Gallonage and weights are approximate.

Cylindrical Secondary Containment Basins

These cylindrical containment tanks (IRD) are available in either virgin high density crosslink or medium density FDA-compliant linear polyethylene. A 2"×2"×3/16" angle iron top support ring is optional and can be ordered separately. Epoxy painted mild steel or 316 stainless steel rings are available. Basins meet or exceed EPA standards. Local regulations should be checked to assure compliance.

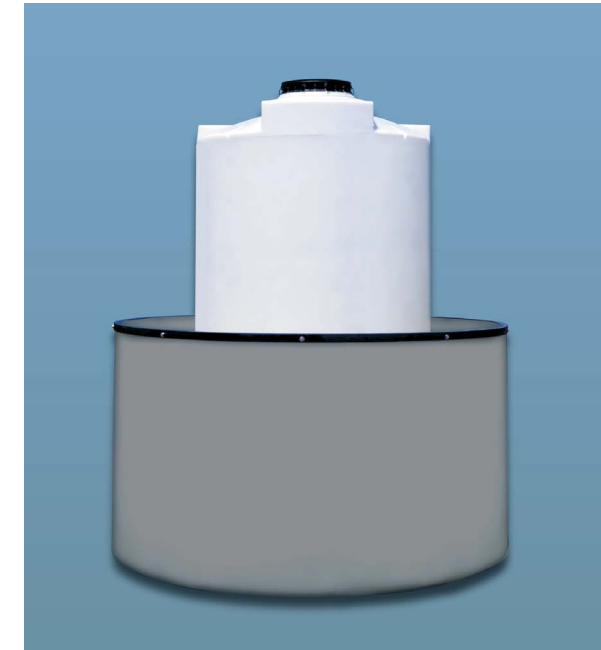

Model Number	Capacity (US Gallons)	Diameter (inches)		Contains Tank Max. Diameter (inches)
		Diameter	Cut Height	
IRD 550	up to 690	60	0 to 58	48
IRD 1050	up to 1200	72	58 to 72	64
IRD 1550	1200 - 1800	72	72 to 108	64
IRD 2300	1800 - 2300	72	108 to 135	64
IRD 1100	up to 982	86	0 to 40	82
IRD 150A	982 to 1301	86	40 to 53	82
IRD 2000	1301 to 1891	86	53 to 77	82
IRD 2500	1891 to 2406	86	77 to 98	82
IRD 3000	up to 2881	90	0 to 107	86
IRD 4000	2881 to 3877	90	107 to 144	86
IRD 1850	up to 1760	96	0 to 58	92
IRD 2400	1760 to 2277	96	58 to 75	92
IRD 2900	2277 to 2762	96	75 to 91	92
IRD 4100	up to 3900	119	0 to 84	115
IRD 4200	2762 to 4200	96	91 to 140	92
IRD 5600	4200 to 5300	96	140 to 177	92
IRD 5200	up to 4800	105	0 to 133	101
IRD 6500	4800 to 6200	105	133 to 172	101
IRD 5500	3900 to 5400	119	84 to 116	115
IRD 6510	5400 to 6100	119	116 to 131	115
IRD 8000	up to 7800	143	0 to 116	139
IRD 10000	7800 to 9900	143	116 to 147	139
IRD 12000	9900 to 11000	143	147 to 163	139

Model number availability and individual specifications subject to change without notice. Gallonage and weights are approximate. All wall thicknesses conform to ASTM D-1998.

Accessories

Assmann offers a wide variety of accessories to compliment our storage tank line. These accessories vary in material type. The table on this page identifies the material options available for the accessories on the upcoming pages.

COMPONENT MATERIAL OPTIONS

Accessory	Fitting Material	Encapsulated Bolt/Capsule	Flange Gasket	Flange Adapter	Siphon Drain
Flange Fittings	PVC P/P 316 SS CPVC PVDF Virgin P/P	SS/EPDM SS/VITON Titanium/EPDM Titanium/VITON Has/VITON	EPDM VITON XLPE BUNA-N	PVC P/P 316 SS CPVC PVDF Virgin P/P	PVC P/P 316 SS CPVC PVDF Virgin P/P

Accessory	Fitting Material	Gasket	Flange Adapter	Siphon Drain
Bulkhead Fittings	PVC P/P CPVC PVDF Virgin P/P	EPDM VITON XLPE BUNA-N	PVC P/P CPVC PVDF Virgin P/P	PVC P/P CPVC PVDF Virgin P/P

Accessory	Type	Gasket	Flange Adapter	Siphon Drain
Stainless Fittings	Male Female Double Male	EPDM VITON XLPE BUNA-N	PVC P/P CPVC PVDF Virgin P/P	PVC P/P CPVC PVDF Virgin P/P

Accessory	Fitting Material	Gasket	Flange Adapter
Self-Aligning Dome Fittings	PVC	EPDM VITON XLPE BUNA-N	PVC CPVC P/P

Accessory	U-Vent Material	Gasket	Screen
U-Vent Assemblies	PVC Sch 40 PVC Sch 80 P/P Sch 80 CPVC Sch 80	EPDM VITON XLPE BUNA-N	Stainless Steel

Accessory	Fill Line Material	Drop Tube Material	Bracket Bolts Bolt/Capsule	Bracket Gasket	Union
Fill Line/ Drop Tube Assemblies	PVC P/P	PVC P/P	SS/EPDM SS/VITON Titanium/EPDM Titanium/VITON Has/VITON	EPDM VITON XLPE BUNA-N	PVC P/P

Accessory	Type	Sight Gauge Material	Ball Valve Seals
Sight Gage Assemblies	Single Valve Double Valve Triple Valve	PVC	EPDM VITON

Accessory	Elbow Material
Anti-Foam Elbow	PVC P/P CPVC PVDF

LEGEND	
Abbreviation	Material
PVC	Polyvinyl Chloride
P/P	Polypropylene
316 SS	Type 316 Stainless Steel
CPVC	Chlorinated Polyvinyl Chloride
PVDF	Polyvinylidene Fluoride
Virgin P/P	Unpigmented Virgin Polypropylene
Tit	Titanium
Has	Hastelloy
EPDM	Ethylene Propylene Diene Copolymer
VITON	DuPont Fluoroelastomer
XLPE	Crosslinked Polyethylene
BUNA-N	Butadiene Elastomer

Flange Fittings



Flange fittings provide a means to connect inlet or drainage plumbing through the wall of the tank. Secured by metal bolts encapsulated in EPDM or VITON elastomers which provides compression for a positive seal. Order by size and material. Bolts, gasket and flange must be ordered separately. Assmann's ANSI-150 psi flange adapter, consisting of nipple and flange, converts a threaded connection to a mating flange. Length of the adapter can be made to your specifications. Siphon drain consists of welded nipple, 90° elbow and nipple to extend to 1/2-inch above tank floor.

Flange Fittings Available Sizes (inches)											
Size	1/2	3/4	1	1 1/4	1 1/2	2	2 1/2	3	4	6	8
Bolts	4	4	4	4	4	4	4	4	8	8	8

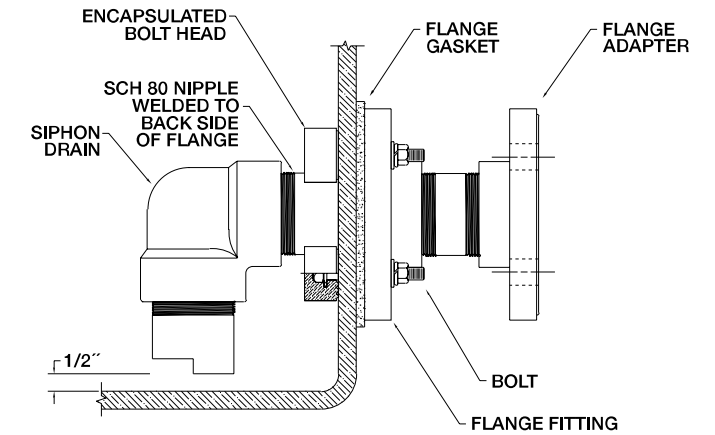

Bulkhead Fittings

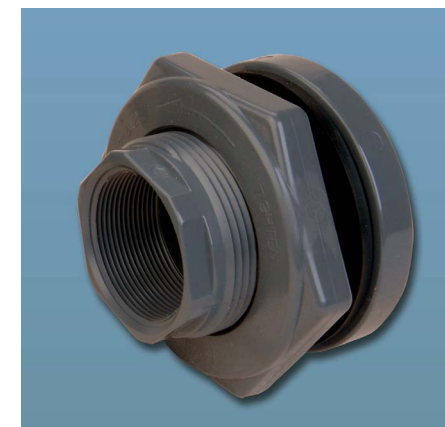

Bulkhead fittings are economical tank to plumbing connections available in a variety of materials. Bulkhead fittings and gaskets must be ordered separately. Siphon drains are threaded to fit to bulkhead fittings. Assmann's ANSI-150 psi flange adapter, consisting of nipple and flange, converts a threaded connection to a mating flange.

Bulkhead Fittings Available Sizes (inches)									
Size	1/2	3/4	1	1 1/4	1 1/2	2	3	4	

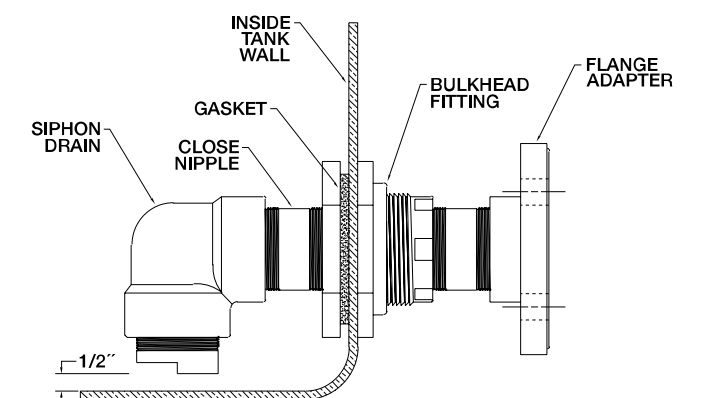



316 Stainless Steel Fittings

These fittings provide the through tank wall connection for applications with stringent sanitary requirements met by Type 316 Stainless Steel. All components except the gasket are made of 316 Stainless Steel.

There are three types in nine sizes:

Male Fitting: Male pipe thread outside tank wall only.

Female Fitting: Female pipe thread inside and outside of tank wall.

Double Male Fitting: Male pipe thread inside and outside of tank wall.

The flange adapter and siphon drain (if applicable) can be applied to all three stainless fitting types listed above.

316 Stainless Steel Fittings Available Sizes (inches)									
Size	1/2	3/4	1	1 1/4	1 1/2	2	2 1/2	3	4
Bolts	4	4	4	4	4	4	4	8	8

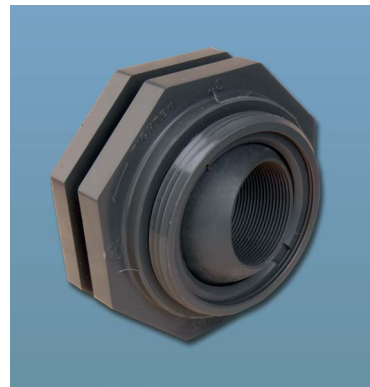
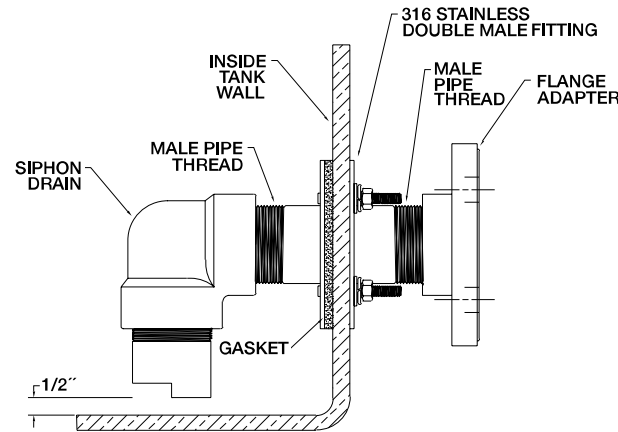

PVC Self-Aligning Dome Fittings

Three sizes of PVC fittings are available which provide a vertical plumbing connection at the top of tanks with a radius dome. The ball socket design corrects for the slope of the dome. The fittings have female pipe thread inside and outside of tank wall. Fitting and gasket must be ordered separately.

Self-Aligning Dome Fittings Available Sizes (inches)			
Size	1	2	3

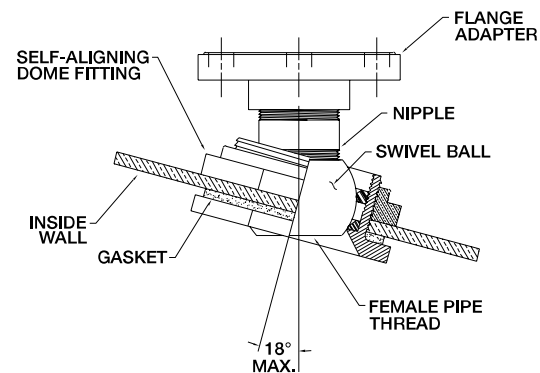

Polyethylene Welded Connections for Linear Tanks

FDA compliant welded polyethylene fittings are suitable for use in food, cosmetic, and pharmaceutical industries. Certified welders provide a variety of custom welded accessories. Polyethylene welded fittings and some welded accessories may only be welded to 1.9 specific gravity or higher tanks.

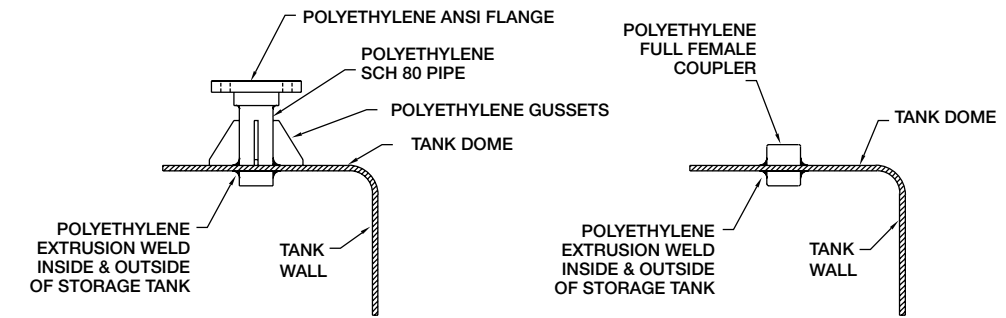

Polyethylene Full Female Couplers Available Sizes (inches)					
Size	3/4	1	1 1/2	2	3

Polyethylene Flange Connections Available Sizes (inches)								
Size	1	2	3	4	6	8	10	12

Polyethylene Pipe Support Brackets Available Sizes (inches)			
Size	1-3	4-6	8-12

Polyethylene Sch 80 Pipe Per Foot Available Sizes (inches)								
Size	1	2	3	4	6	8	10	12

Vent Assemblies

Vent assemblies are available in sizes from 2-inch to 6-inch. Vent gasket and bolts (where applicable) must be ordered separately. Stainless steel screens are optional and must be ordered separately.

Vent Assembly Sizes (inches)				
Sizes	2	3	4	6

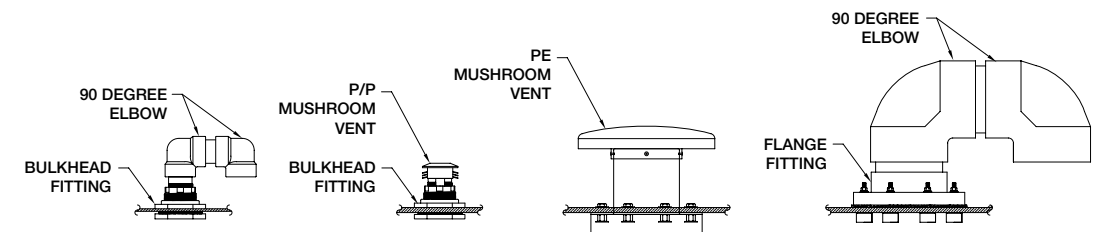



Fill Line / Suction Line Assemblies

These assemblies make it possible to fill the tank from a convenient position outside the tank. They do not include through-wall fittings. The fill line consists of an exterior drop tube, 90° elbow, ball valve, male quick disconnect coupling, dust cap and exterior pipe support bracket. The interior assembly consists of drop tube and pipe support bracket. Gasket and bolts must be ordered separately.

Optional union may be ordered with exterior fill line. Optional foot valve may be ordered with internal suction line.

Fill Line Assemblies Available Sizes (inches)			
Size	1	2	3

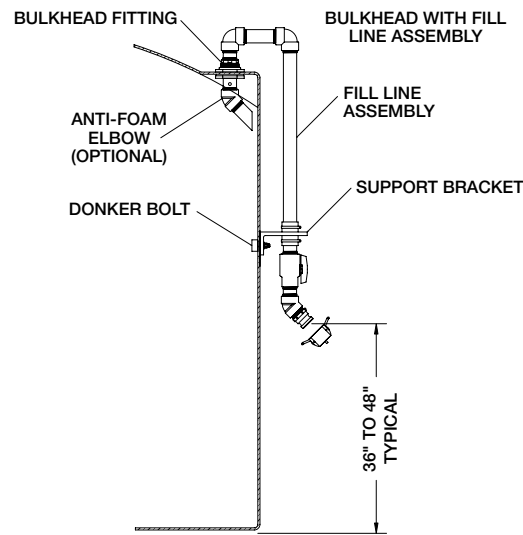

Fill Line / Anti-Foam Elbows

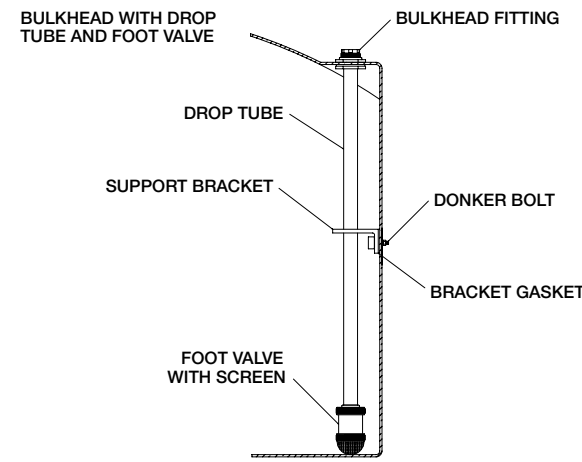

Top Suction

Anti-Foam Elbow

This assembly with 45° elbow and nipple extends to within 3" of the tank wall, directs liquid to run smoothly down the interior surface of the tank. This will reduce the generation of foam on the surface of the contents. Through-wall fitting is not included and must be ordered separately.

Anti-Foam Elbow Available Sizes (inches)				
Size	1	2	3	4

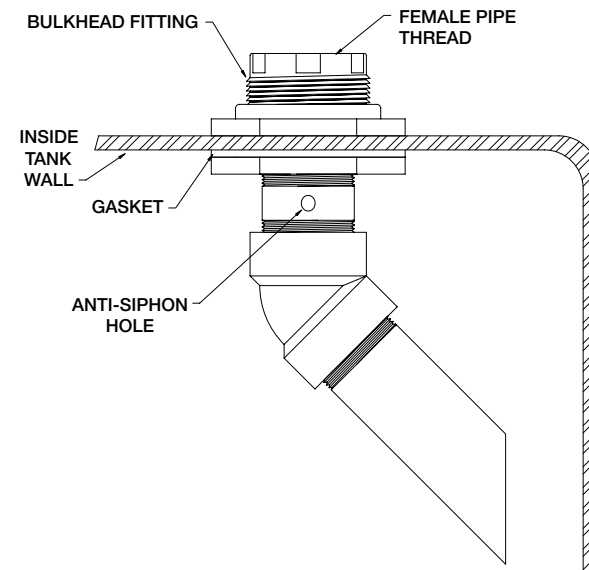

Sight Gauge Assemblies

Sight gauge assemblies of 3/4-inch PVC tubing and fittings are available in single, double and triple valve configurations as illustrated. Assembly consists of ball valve(s), nipples, 90° elbows, stainless steel hose clamps, hose barbs, clear flexible

PVC and threaded T-fitting where applicable. Through-wall fittings and/or bulkhead fittings (shown in illustration) are not included and must be ordered separately.

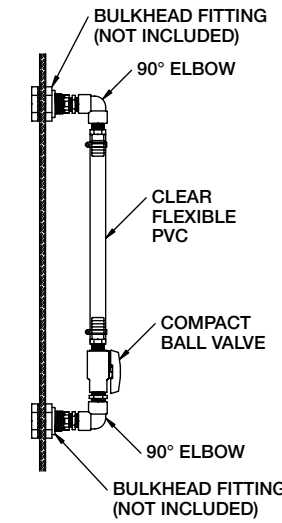

Single Valve Sight Gauge

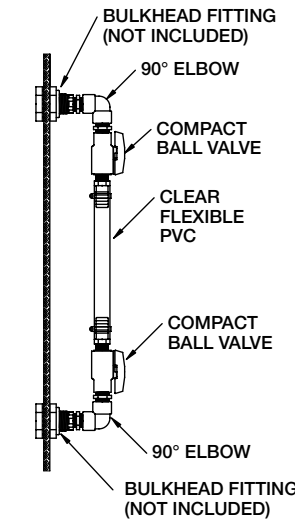

Double Valve Sight Gauge

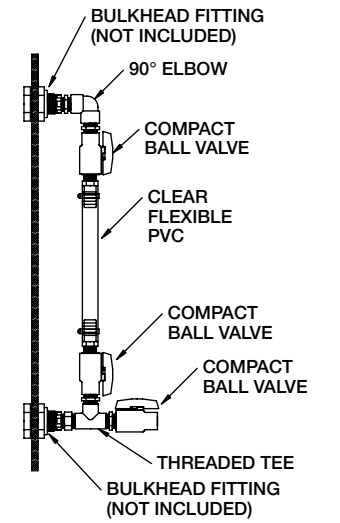

Triple Valve Sight Gauge

Leak Detection



Interstitial Leak Detection System with Audible and Visual Alarms

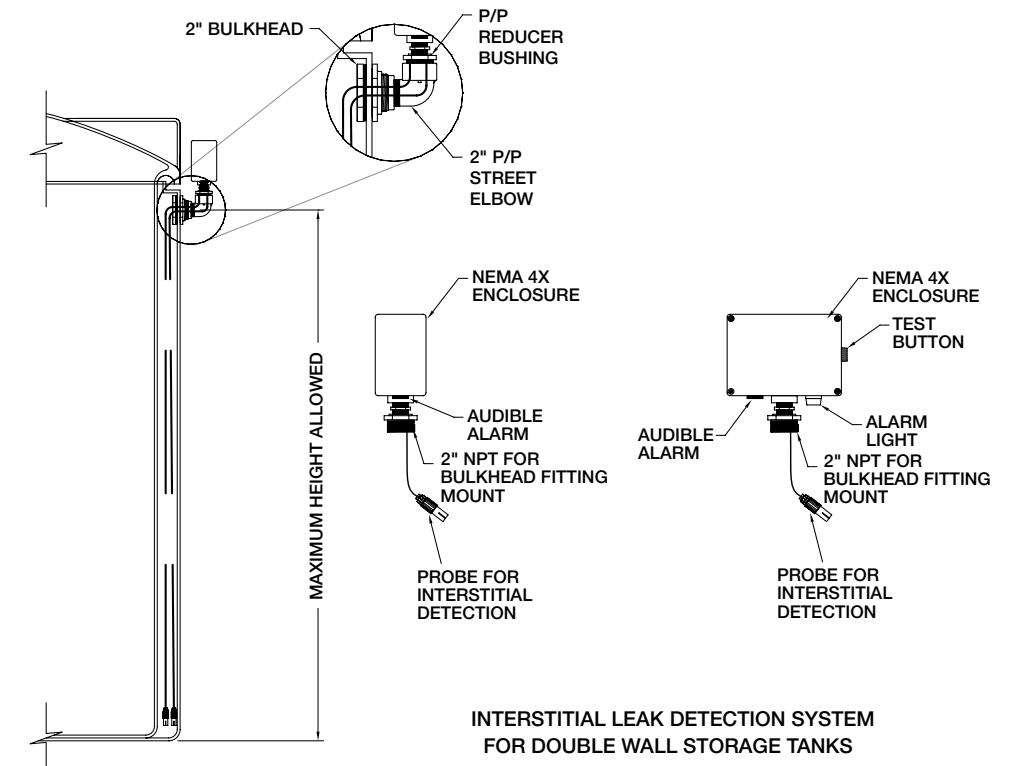

INTERSTITIAL LEAK DETECTION SYSTEM FOR DOUBLE WALL STORAGE TANKS

Passive Restraint Assemblies

Vertical Tank Passive Restraint (Band Type)		
Tie Down Number	Tank Diameter (inches)	Number of Legs & Bands
TDA 35	35	3
TDA 48	48	4
TDA 64	64	4
TDA 69	69	4
TDA 86	86	4
TDA 90	90	4
TDA 96	96	4
TDA 105	105	4
TDA 119	119	6
TDA 143	143	6

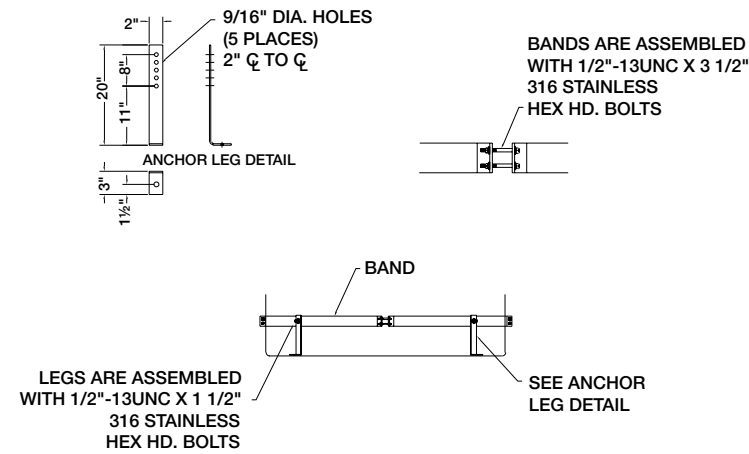

Tie-Down Assemblies

Seismic Zone 4

Seismic restraint assemblies are designed to handle seismic loads up to and including zone 4. Materials of construction consist of: 316 Stainless Steel or Mild Steel with epoxy coating and galvanized cables.

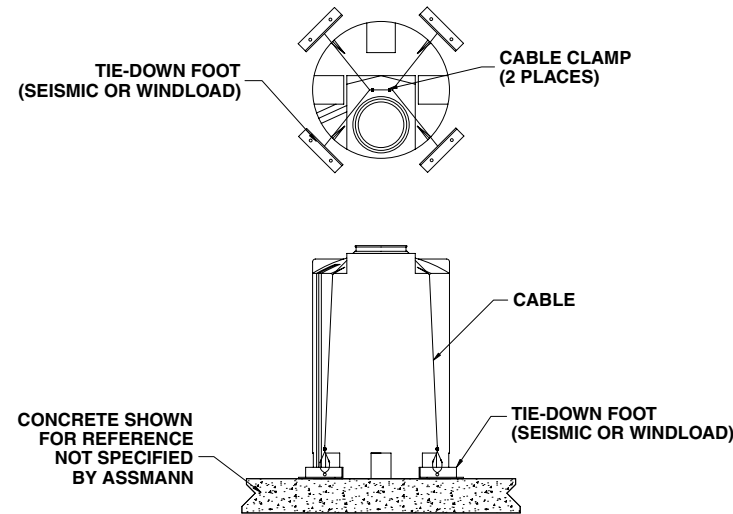

120 MPH Wind Load

Wind load tie down assemblies are capable of handling winds up to and including 120 MPH. Materials of construction consist of: 316 Stainless Steel or Mild Steel with epoxy coating and galvanized cables.

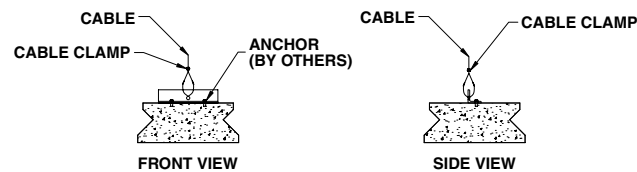

Molded Polyethylene Restraint & Lifting Lugs System

Assmann Corporation introduces our new molded polyethylene restraint and lifting lugs system. This system has been engineered for long term exposure in corrosive environments. Easily installed with factory cabling, this system has been certified on applications with 150 MPH sustained wind loads.

This is the first ever polyethylene restraint system that combines both a restraint and a lifting system all in one package. The unique bump stop encompassed the tanks knuckle radius dramatically reducing the tanks over turning moment. While the mechanically fastened lifting lugs make for easy empty tank placement and removal.

Cable types available are either Galvanized or 316 Stainless Steel. Site specific calculations make this system the most economical engineered system on the market today.

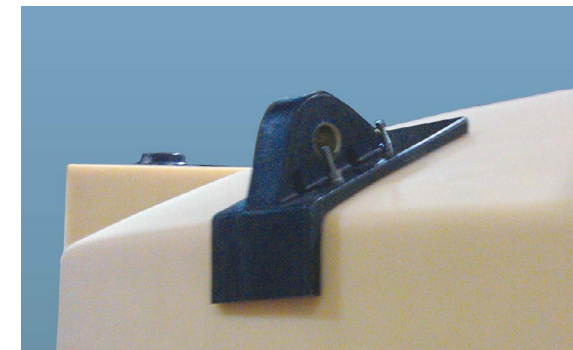

Molded Polyethylene Lifting Lugs

Assmann also offers polyethylene molded lifting lugs as inexpensive answer to positioning your polyethylene chemical storage tank.

These lugs are constructed of linear polyethylene with stainless steel encapsulated inserts. The internal insert is covered with polyethylene so they are 100% corrosion resistant in harsh chemical environments. Sold in sets of four, these can be used on all vertical storage tanks 550 gallons and larger.

Lugs pictured in black. Black is standard color unless otherwise specified when ordering. Cable shown in picture is not included.

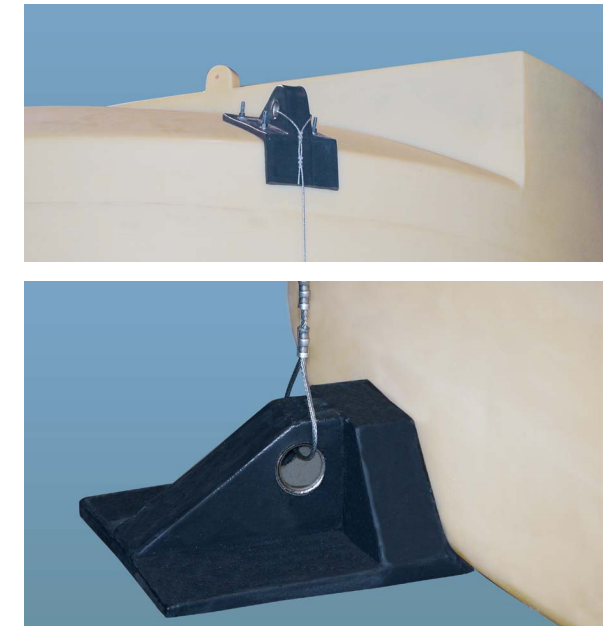

Reverse Float Level Indicator

Assmann Corporations Reverse Float Level indicator is an excellent way to eliminate sidewall penetrations on your polyethylene tank.

This system shows liquid level in your storage tank by utilizing a molded polyethylene float that rides on the liquid within. A bright orange target shows the liquid level in reverse action, as the liquid in the tank drops, the bright orange target rises, so you can have an approximate level in the tank.

This gauge is ideal for use on colored tanks, insulated tanks or double wall tanks when you cannot see the liquid level through the tank wall. Available from both our Garrett, In and Marshall, TX Facilities!



Tank Heat Tracing and Insulation

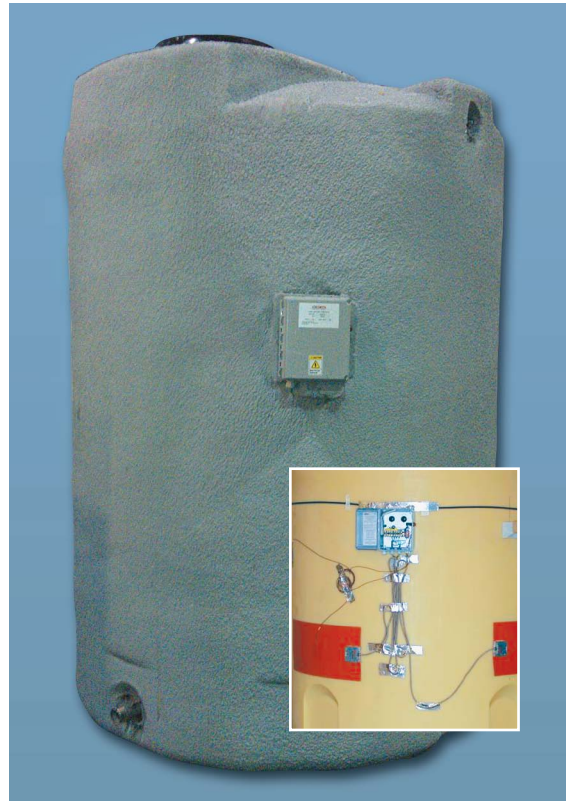

Assmann tanks are available with a heating system to maintain the level required by temperature sensitive stored liquids. Adhesive backed thin carbon strip heat tracing elements embedded in clear polyester film are wrapped around the tank and covered with a two-inch thick layer of polyurethane foam insulation covered with two coats of mastic. A control panel regulates temperature measured by high level and maintenance level thermostats set to desired limits. Using different heat tracing elements, temperature can be maintained at any point above 50°F, 80°F or 100°F over the lowest ambient temperature to which the tank is subjected. Heat tracing and insulation are available for vertical tanks from 300 to 12,000 gallons capacity, conical bottom tanks from 1,575 to 4,200 gallons and horizontal cylindrical tanks from 500 to 2,500 gallons. When requesting information, specify the gallon capacity and the Delta T (DT) for your material (the temperature differential is calculated by subtracting the minimum ambient temperature to which the tank is subject from the temperature at which your material must be maintained).

Control box (115V dual thermostats, 1 high level, 1 maintenance level).

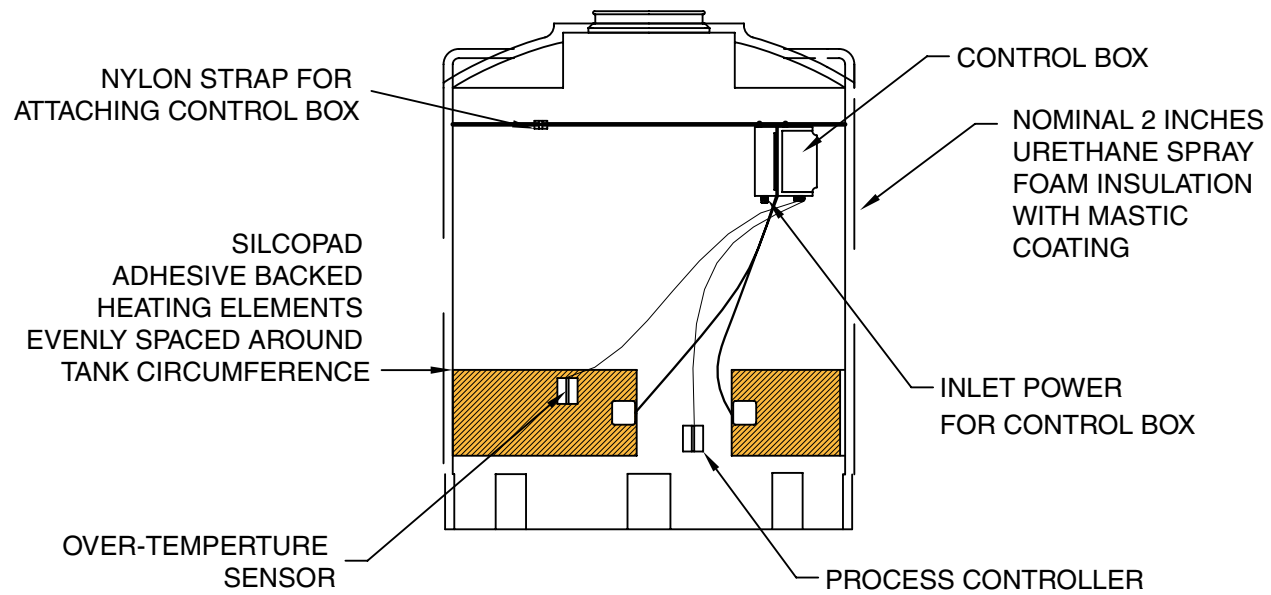

Fiber Reinforced Ladder Assemblies

Fiber reinforced ladders conform to OSHA requirements. Ladder assemblies are available in three configurations. Ladder with platform, straight ladder with cage and ladder with cage and platform. These ladders are not designed to gain entry into interior of tanks or for access to dome.

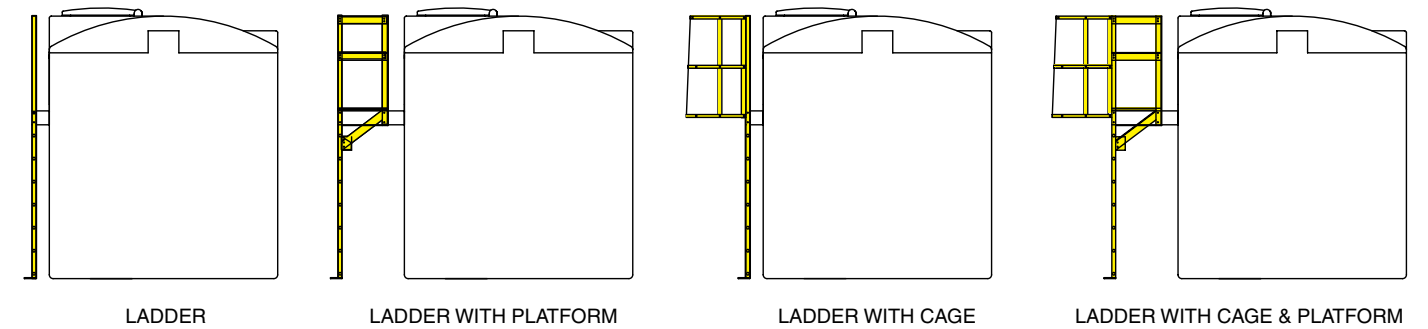

FRP Ladder with Platform

FRP Ladder with Cage

FRP Ladder with Cage and Platform

Agitator Support Brackets for Vertical and Conical Tanks

Self supporting agitator support brackets are designed to handle mixers with horse power ratings of 3 or 5 HP. Agitator support stands are made from mild steel and are epoxy painted as a standard. 304 stainless steel is optional.

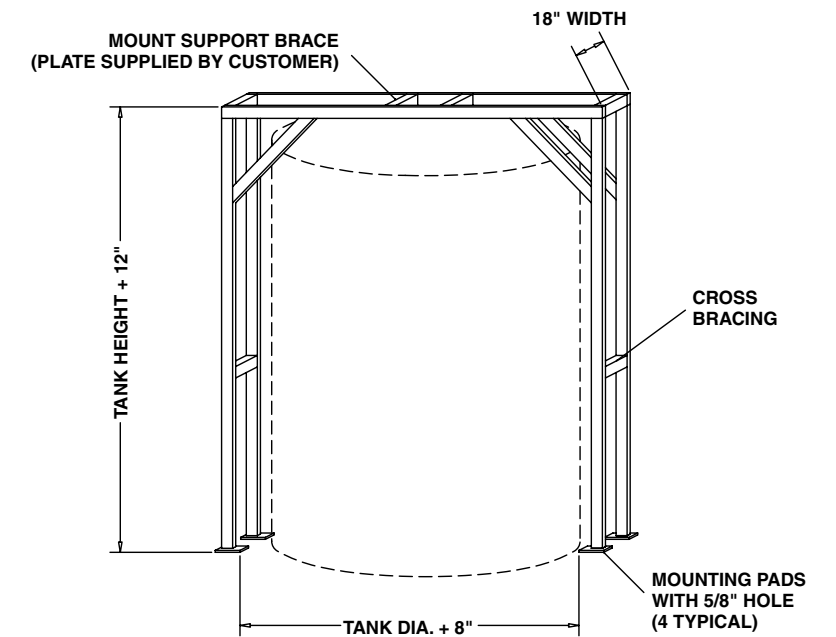

CUSTOMER TO PROVIDE MIXER MOUNTING HOLES/BOLTS OR PLATE ONSITE
 3HP WITH 18" MOUNTING SUPPORT SPACING 2" x 2" x 3/16" TUBE 4" x 6" x 1/4" MOUNTING PADS
 5HP WITH 24" MOUNTING SUPPORT SPACING 3" x 3" x 3/16" TUBE 4" x 8" x 1/4" MOUNTING PADS

Checklist of Information We Need to Know

For additional information regarding Assmann polyethylene tanks, please contact your local Authorized Assmann Distributor

or Representative. The following is information needed to provide accurate pricing and details for your application.

- Chemical or fluid to be stored
- Volume/gallons to be stored
- Type of polyethylene for intended application
- Address of installation location
- Estimated completion date desired
- Number of tanks, model, dimensions, color anticipated
- Fittings, size, material desired
- Space limitations, ambient environment characteristics
- Temperature maintenance requirements
- Contact name, phone, fax number

The Assmann Warranty

Assmann warrants our tanks to be free from defects in workmanship and materials, under normal use and service, to the original purchaser for a period of 5 years from the date of shipment from our factory. Installation and operation must comply with all applicable federal, state, and local regulations, and must be in accordance with applicable instructions and limitations contained in the Assmann Usage and Handling guidelines for the tank. Warranty shall not apply to any product that after leaving our factory: 1) has been repaired or altered in any manner not authorized by Assmann; 2) has been subject to abuse, misuse, fire, accident, neglect, or improper handling; 3) has not been used in accordance with Assmann chemical resistance charts; 4) has been exposed to pressures greater than atmospheric pressure; 5) has been exposed to internal or external temperatures greater than 120° F (for linear polyethylene) or 150° F (for Crosslink polyethylene); or 6) has been connected, installed, adjusted or used otherwise than in accordance with the instructions provided by Assmann. Assmann's sole liability and our customers' sole remedy shall be limited to the warranties contained within exclusive warranty. Under no circumstances, shall Assmann be liable for special, indirect, incidental, punitive or consequential damages resulting from the performance or operation of any product manufactured or sold by Assmann.

Consult factory for full copy of Assmann Corporation of America's exclusive Warranty.



Assmann Corporation of America
300 N. Taylor Road, Garrett, IN 46738

Phone: 888-357-3181 • Fax: 888-Tank Fax (826-5329)

Phone: 260-357-3181 • Fax: 260-357-3738

E-mail: info@assmann-usa.com

Internet: www.assmann-usa.com

Manufacturing facilities in Garrett, IN and Marshall, TX

Authorized Distributor: